



80L Industrial Vacuum

10678

INSTRUCTION MANUAL

www.monstershop.co.uk



SPECIFICATION

PRODUCT DESCRIPTION

Keep that warehouse not only organised, but now clean with the Maxblast 80 Litre Industrial Vacuum. It is perfectly suited towards any industrial environment, but can adapt to any location – as long as there's a power outlet for the plug socket!

The highly powerful 3000 Watt motor can vacuum both wet and dry substances with one of its four hose attachments. Choose from the two floor brushes, the bristle and crevice nozzle attachment.

Effortless to empty and fill the stainless steel drum, combined with the 80 Litre tank capacity and easy to manoeuvre castor wheels means you really can clean every nook and cranny.

PRODUCT SPECIFICS

DIMENSIONS:	58.5 (L) x 57.3 (W) x 99cm (H)
WEIGHT:	28kg
POWER:	3000W
VOLTAGE:	230 V / 50Hz
AMPERAGE:	10A
AIR FLOW:	106 L/S
NOISE LEVEL:	80dB
FILTER:	Cloth filter
DRUM CAPACITY:	80L

SPECIFICATION

PRODUCT FEATURES

- A. Vacuum Attachment
- B. Pedestal
- C. Stainless Steel Drum
- D. Vacuum Hose
- E. Handle
- F. Power Switch
- G. Drain Hose
- H. Wheel



Monster Group UK Limited's liability will be limited to the commercial value of the product only.

SAFETY ADVICE

SAFE WORKING PRACTICE

Please read through the Safe Working Practice to ensure prevention of injury or damage to the device.

- Do not use this product for anything other than its intended purposes.
- Ensure you have read and fully understood the instruction manual and safety advice before using this product.
- Do not use the machine if the power cord is frayed or damaged.
- When the device is not in use ensure that the power plug is removed from the socket. This will prevent damage to the appliance through power surges.
- This appliance can be dangerous if the power cord or wires come into contact with water.
- Clean this product after use and unplug the appliance from the wall whilst cleaning.
- Do not overwork the machine.
- If damaged, do not operate the machine.
- Do not pour water on the electrical housing or near the vents.
- Appropriate clothing must be worn whilst operating this machine.
- Keep clean to prolong the life.
- Do not jam the air inlet mouth.
- Do not operate near combustible and explosive areas/items.
- Do not vacuum combustible, explosive or sharp items.
- Do not turn the machine upside down.
- When repairing, remove plug from power supply.

SAFETY ADVICE

! SAFE WORKING PRACTICE

- Keep away from bright sunlight and high temperatures.
- To clean, do not pour water on it. Wipe down and dry with a cloth.
- Check the filter before each use.

Wet Vacuuming:

- Empty the water regularly.
- Avoid any collision with the vacuum that could knock it over. If this happens, the float will be suctioned to the top of the vacuum due to pressure, and it will not release. This could cause the float to melt and the motor to overheat. In the event that this happens, to stop the process please turn the vacuum off and empty the water. Once the float reaches the bottom you can continue vacuuming.
- If you experience loss of suction, or if there is a change in motor noise, turn off your vacuum and empty the water. These signs could mean that the float is near the top.
- When using the vacuum cleaner for water, remember to remove the cloth filter.

Dry Vacuuming:

- Check the filter is in good condition before using the vacuum. If there is dust appearing in the motor head, the filter may be broken or incorrectly installed.



Wet Floor Nozzle

For carpet and hard flooring.

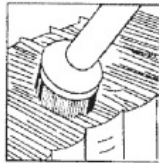

Bristle

For windows and tables.



Crevice Nozzle

For tight corners and crevices.

SPECIFICATION

PRODUCT PARTS

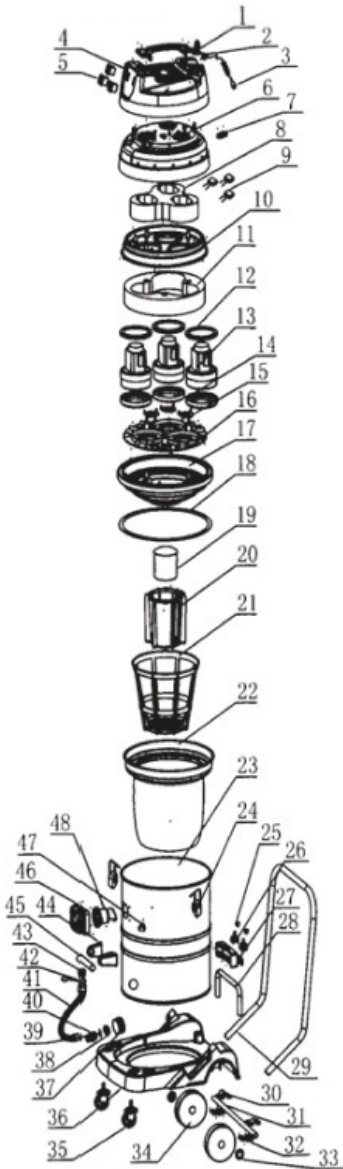

- | | |
|------------------------------|--------------------------|
| 1. Handle | 36. Pedestal |
| 2. Coating | 37. Tight Gasket |
| 3. Power Cable | 38. Water Outlet |
| 4. Top Cover | 39. Rubber Gasket |
| 5. Switch | 40. Water Outlet Screw |
| 6. Middle Cover | 41. Water Outlet Hose |
| 7. Pad | 42. Connector Ring |
| 8. Sponge | 43. Water Outlet Coating |
| 9. Capacitor | 44. Handle Pedestal |
| 10. Middle Cover Gasket | 45. Stainless Steel Tube |
| 11. Air Outlet Sponge | 46. Suction Pedestal |
| 12. Upper Gasket | 47. Ring |
| 13. Motor | 48. Suction Valve |
| 14. Lower Gasket | |
| 15. Air Inlet Blocking Board | |
| 16. Motor Pedestal | |
| 17. Drum Cover | |
| 18. Wind Tight Ring | |
| 19. Protective Valve | |
| 20. Pedestal Basket | |
| 21. Support Basket | |
| 22. Filter | |
| 23. Drum | |
| 24. Drum Lock | |
| 25. Locking Block | |
| 26. Turnover Part | |
| 27. Turnover Shelf | |
| 28. Turnover Support Shelf | |
| 29. Base Big Handrail | |
| 30. Axle Press-Cover | |
| 31. Axle | |
| 32. Axle Press-Bottom | |
| 33. Cork | |
| 34. Rubber Wheel | |
| 35. Wheel | |

USER GUIDE

ASSEMBLY INSTRUCTIONS

1. Start by assembling the wheels on the vacuum. Push the two front castor wheels into the corresponding pedestal holes.
2. Push the wheels firmly into place to ensure they are attached properly.
3. Line up the rear wheels with the mounting holes and cover with the pressure plates, as shown below.
4. Screw the pressure plates into place to secure the rear wheels.



5. Insert the hose connector into the air inlet mouth. Make sure the connector is securely fastened.
6. Check the dual filter is in place for dry vacuuming. If you are wet vacuuming, remove everything from the drum. Place the power cord right at the back of the drum when in use. If you wish, before dry vacuuming, you can add the dust bag.
7. Attach desired vacuum nozzle.
8. Switch on at mains, and press 'On' button to power up.

USER GUIDE

CLEANING CARE

DRUM CLEANING

If you have noticed the suction has decreased, the drum is full. To empty:

- First you need to switch off at the power supply.
- Unfasten the locking knob and lift off the top cover.
- Take off the filter bag and clean the dust away from the drum.
- When empty, replace the clean filter bag and lock the top cover back into place.

DUAL FILTER CLEANING

- The Cloth Filter should be washed with warm water. If required, you can use a soft cloth to wipe.
- Remove the filter before cleaning and allow to dry before re-installing.

Note: The Dust Bag should not be washed, please ensure you are washing the Cloth Filter, not the Dust Bag.



TROUBLESHOOTING

RESOLUTION GUIDE

WHAT DO I DO IF THERE ARE MISSING PARTS FROM MY ORDER?

If there appears to be any part missing from your order, contact our friendly and helpful Customer Support Team within 7 days of receipt.

THE VACUUM HAS LOST SUCTION

Ensure the vacuum is empty, the filter is clean and there are no blockages in the hose/ attachment.

MY INDUSTRIAL VACCUM WILL NOT START

Check the plug is attached to a power supply and the drum is empty. Check the fuse in the plug. When checking the fuse, ensure the vacuum is switched off at the mains. If it still will not start, simply call or email our Support Team. They will guide you through issues or arrange a date and time for us to collect the product and fix it with our 12 month guarantee.

MY HOSE ATTACHMENT ISN'T WORKING PROPERLY

Check the vaccum filter as this can become blocked and need cleaning. The hose itself can also become obstructed by objects stuck in the pipe, so please check the hose for any blockages.

**FOR ALL OTHER ISSUES, PLEASE CONTACT OUR
CUSTOMER SUPPORT TEAM.**

Monster Group (UK) is one of the UK's fastest growing online retailers. We supply a diverse range of products which offer exceptional value for money. We strive to provide the best possible customer experience with free UK delivery across all our products and a Monster Guarantee for 100% satisfaction.

For information regarding this device or other products from our Monster divisions please contact Sales.

SALES

TEL: 01347 878 888

EMAIL: hello@monstershop.co.uk

For queries about this device, warranty, returns or reporting faults please contact Support.

SUPPORT

TEL: 01347 878 887

EMAIL: help@monstershop.co.uk

Pour plus d'informations concernant cet appareil ou d'autres produits de nos divisions de Monster veuillez utiliser les détails suivants ci-dessous.

DÉPARTEMENT COMMERCIAL

TEL: 01347 878 888

EMAIL: bonjour@monstershop.eu

Pour les interrogations concernant cet appareil, la garantie, les retours ou les défauts de déclaration veuillez utiliser les détails suivants ci-dessous.

DÉPARTEMENT DE SOUTIEN

TEL: 01347 878 887

EMAIL: help@monstershop.co.uk

Para información sobre este dispositivo u otros productos de nuestras divisiones de Monster por favor use los siguientes detalles.

DEPARTAMENTO DE VENTAS

TEL: 01347 878 888

EMAIL: hola@monstershop.eu

Para consultas sobre este dispositivo, la garantía, devoluciones o denuncias de fallos por favor use los siguientes detalles.

DEPARTAMENTO DE SOPORTE

TEL: 01347 878 887

EMAIL: help@monstershop.co.uk

Für Informationen bezüglich dieses Geräts oder anderer Produkte aus unserer Monster-Abteilung, benutzen sie die folgenden unten aufgeführten Angaben.

VERKAUFABTEILUNG

TEL: 01347 878 888

EMAIL: hallo@monstershop.eu

Für Fragen über dieses Gerät, die Garantie, Rückgaben oder bei Störungen, benutzen sie die folgenden unten aufgeführten Angaben.

SUPPORT-ABTEILUNG

TEL: 01347 878 887

EMAIL: help@monstershop.co.uk

Per informazioni riguardanti questo dispositivo o altri prodotti dalle categorie Monster utilizzare i dettagli sotto riportati.

DIPARTIMENTO VENDITE

TEL: 01347 878 888

EMAIL: ciao@monstershop.eu

Per domande riguardo dispositivo, garanzia, reso o per riferire di guasti, utilizzare i dettagli sotto riportati.

DIPARTIMENTO SUPPORTO

TEL: 01347 878 887

EMAIL: help@monstershop.co.uk

Monster House, Alan Farnaby Way,
Sheriff Hutton Industrial Estate,
Sheriff Hutton, York, YO60 6PG
www.monstershop.co.uk



 Try **Monster**. Buy **Monster**. Be **Monster**. 