

Anti Theft Parcel Postbox

210555 / 210557

INSTRUCTION MANUAL

www.monstershop.co.uk



SPECIFICATION

PRODUCT DESCRIPTION

The Monster Shop Smart Parcel Box is an easy to use, secure delivery post box which will keep your parcels safe whilst you are away from home. This smart post box features an anti-fishing design so that delivered parcels can only be retrieved from the holding compartment.

The Smart Parcel Post Box can accept multiple deliveries each day. On your return, simply use your access key, to retrieve your parcels. The post box provides a unique barcode which can be scanned or recorded by couriers and used as proof of delivery, should your delivery require it.

PRODUCT SPECIFICS

DIMENSIONS:	44 x 35 x 57cm
MAX PARCEL SIZE:	35 x 19 x 15cm
KEYS:	2

PARTS LIST



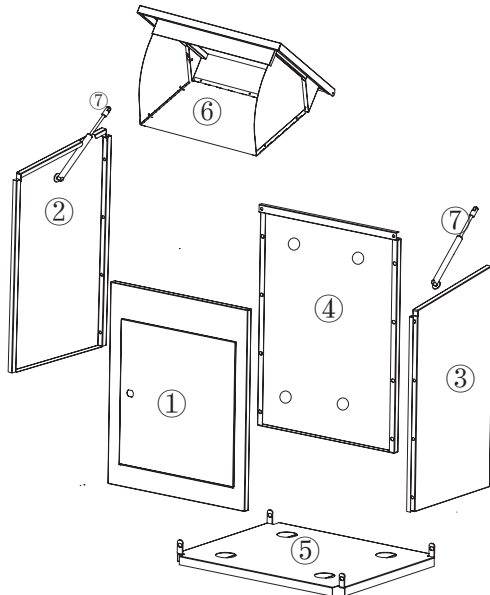



1. Front Panel
2. Left Side Panel
3. Right Side Panel
4. Back Panel
5. Bottom Panel
6. Top Cover
7. Lid Struts





SPECIFICATION

PARTS LIST

ASSEMBLY FIXINGS

Part No.	Illustration	Description	Quantity
A		M5 Nut	X 2
B		M5 Cross Head Screw	X 2
C		M6 Flat Hex Screw	X 22
D		M6 Nut	X 2
E		Hex Key	X 1
F		Spanner	X 1

INSTALLATION FIXINGS

Part No.	Illustration	Description	Quantity
G		M10x5mm Wall Plug	X 4
H		M8x50mm Hexagon Bolt	X 4
I		M8x16mm Washer	X 4

Monster Group UK Limited's liability will be limited to the commercial value of the product only.

SAFETY ADVICE

SAFE WORKING PRACTICE

Please read through the Safe Working Practice to ensure prevention of injury or damage to the device.

- Do not use this product for anything other than its intended purposes.
- Do not alter or modify this product in any way.
- Keep your construction area clear of clutter.
- Ensure children, pets/animals and inexperienced users are not in the vicinity when constructing this parcel post box.
- Regularly inspect the product for damage and sign of wear. Tighten any components that appear to be loose.
- We recommend two people to assemble the product.
- If installing to the ground, check for underground pipes or cables before installing.
- Gloves should be worn when assembling the post box.

USER GUIDE

ASSEMBLY INSTRUCTIONS

NOTE: Only fully tighten the screws once the assembly is complete.

STEP 1:

Attach side panels (2) & (3) to the front panel (1) and secure with 6x M6 Flat Hex Screws (C).

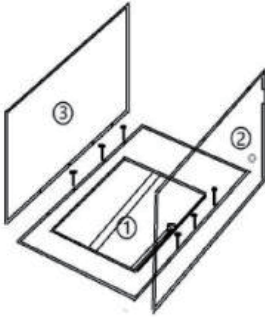

STEP 2:

Stand the built frame upright and attach the back panel (4) using 2x M6 Flat Hex Screws (C).

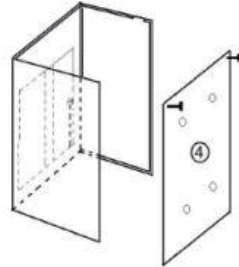

STEP 3:

Now secure the back panel (4) in place from the inside of the frame using 6x M6 Flat Hex Screws (C).

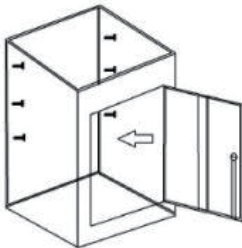

STEP 4:

Now place the bottom panel (5) into the frame. Secure in place with 4x M6 Flat Hex Screw (C).

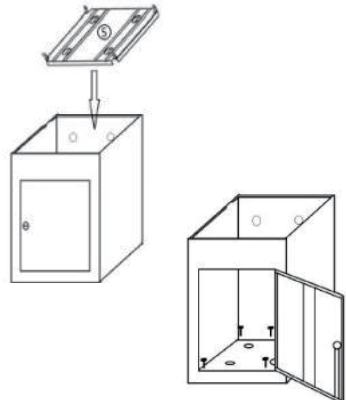

USER GUIDE

ASSEMBLY INSTRUCTIONS

STEP 5:

Unfold the top cover (6) and secure with 4x M6 Flat Hex Screws (C).

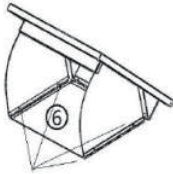

STEP 6:

Place the top cover (6) on top of the frame and secure in place with 2x M5 Cross Head Screws (B) and 2x M5 Nuts (A).

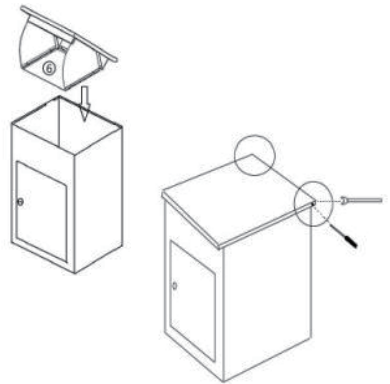

STEP 7:

Attach the lid struts (7) to the side panels (2) and secure in place with 2x M6 Nuts (D).

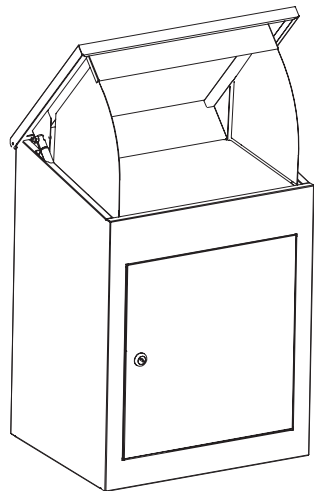
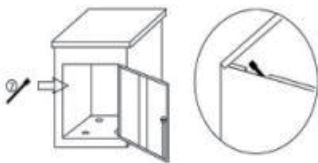

USER GUIDE

INSTALLATION INSTRUCTIONS

WALL INSTALLATION

STEP 1:

Place the Parcel Postbox on the wall in the desired location and mark where the holes need to be drilled.

STEP 2:

Remove the Parcel Postbox from the wall and drill the holes in the marked places using a 10mm drill bit. Insert the 4x wall plugs (G) into the drilled holes.

STEP 3:

Re-position the Parcel Postbox and insert the 4x M8x16mm Washers (I) and 4x M8x50mm Hexagon Bolts through the holes inside the Parcel Postbox and secure tightly to the wall.

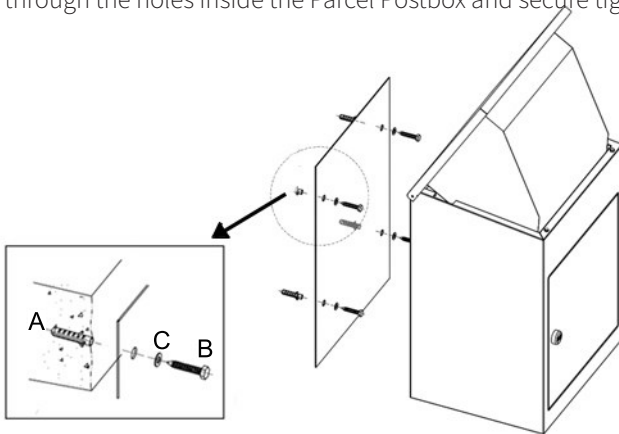

GROUND INSTALLATION

If installing the Parcel Postbox to the ground, please check for underground pipes or cables before drilling.

Repeat the same process as above, ensuring you use an appropriate drill bit for the ground surface.

Use the rubber pads included for covering the back holes to ensure it is water tight.

TROUBLESHOOTING

RESOLUTION GUIDE

WHAT DO I DO IF THERE ARE MISSING PARTS FROM MY ORDER?

If there appears to be any part missing from your order, contact our friendly and helpful Customer Support Team within 7 days of receipt.

**FOR ALL OTHER ISSUES, PLEASE CONTACT OUR
CUSTOMER SUPPORT TEAM.**

SPÉCIFICATIONS

DESCRIPTION DU PRODUIT

La boîte aux lettres/ colis astucieuse de Monster Shop est sécurisée et facile à utiliser. Elle gardera vos colis en sécurité en votre absence. Cette boîte aux lettres astucieuse est dotée d'une conception anti-vol. Les colis ne peuvent être uniquement récupérés que par le compartiment de dépôt.

La boîte aux lettres/ colis peut contenir plusieurs colis par jour. Pour les récupérer, il vous suffit d'utiliser votre clé. La boîte est dotée d'un code-barres unique qui peut être scanné ou enregistré par les coursiers et utilisé comme preuve de livraison, si celle-ci est requise.

CARACTÉRISTIQUES DU PRODUIT

DIMENSIONS:	44 x 35 x 57cm
TAILLE MAX COLIS:	35 x 19 x 15cm
CLÉS:	2

LISTE DES PIÈCES



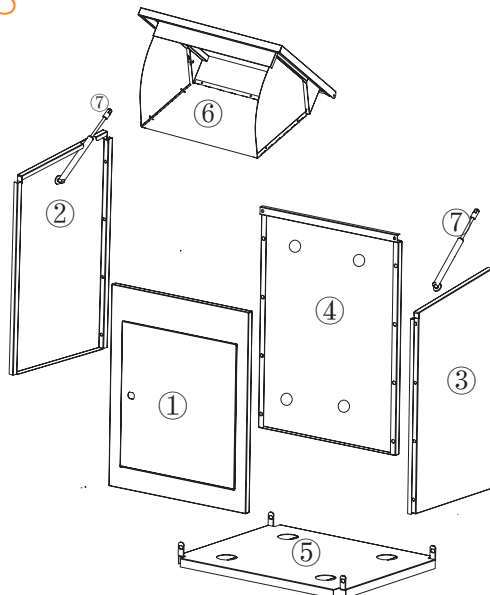



1. Panneau avant
2. Panneau latéral gauche
3. Panneau latéral droit
4. Panneau arrière
5. Panneau inférieur
6. Couvercle supérieur
7. Entretoises





SPÉCIFICATION

LISTE DES PIÈCES

ÉLÉMENTS DE FIXATION

No. PIÈCE	Illustration	Description	Quantité
A		Ecrou M5	X 2
B		Vis cruciforme M5	X 2
C		Vis hexagonale plate M6	X 22
D		Ecrou M6	X 2
E		Clé hexagonale	X 1
F		Clé à molette	X 1

ÉLÉMENTS POUR L'ASSEMBLAGE

No. PIÈCE	Illustration	Description	Quantité
G		Cheville murale M10x5mm	X 4
H		Boulon hexagonal M8x50mm	X 4
I		Rondelle M8x16mm	X 4

La responsabilité de Monster Group UK Limited sera limitée à la valeur commerciale du produit uniquement.

CONSEILS DE SÉCURITÉ

PRATIQUES DE TRAVAIL SÉCURITAIRE

Veillez lire les consignes de sécurité afin d'éviter toute blessure ou tout dommage sur le produit.

- N'utilisez pas ce produit à d'autres fins que celles pour lesquelles il a été conçu.
- Ne pas altérer ou modifier ce produit de quelque manière que ce soit.
- Veillez à ce que la zone d'assemblage soit dégagée de tout encombrement.
- Veillez à ce que les enfants, les animaux domestiques et les utilisateurs inexpérimentés ne se trouvent pas à proximité lors de l'assemblage de cette boîte aux lettres.
- Inspectez régulièrement le produit afin de détecter tout dommage ou signe d'usure. Resserrez tous les composants qui semblent lâches.
- Nous recommandons d'être deux pour monter le produit.
- En cas d'ancrage au sol, vérifiez l'absence de tuyaux ou de câbles souterrains avant de procéder à l'installation.
- Il est recommandé de porter des gants pour assembler la boîte aux lettres.

MODE D'EMPLOI

INSTRUCTIONS D'ASSEMBLAGE

REMARQUE: Ne serrez les vis à fond qu'une fois l'assemblage terminé.

ÉTAPE 1:

Fixez les panneaux latéraux (2) et (3) au panneau avant (1) et fixez-les avec 6x vis hexagonales plates M6 (C).

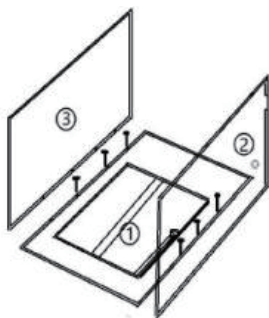

ÉTAPE 2:

Placez le cadre à la verticale et fixez le panneau arrière (4) à l'aide de 2 vis hexagonales plates M6 (C).

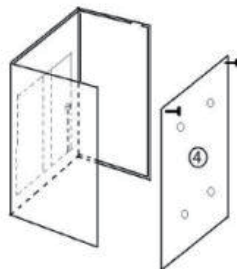

ÉTAPE 3:

Fixez maintenant le panneau arrière (4) depuis l'intérieur du cadre à l'aide de 6x vis hexagonales plates M6 (C).

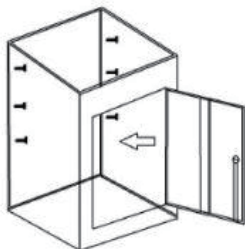

ÉTAPE 4:

Placez maintenant le panneau inférieur (5) dans le cadre. Fixez-le à l'aide de 4 vis hexagonales plates M6 (C).

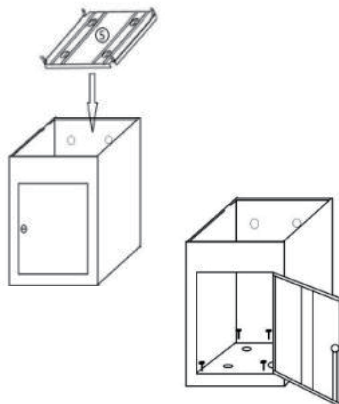

MODE D'EMPLOI

INSTRUCTIONS D'ASSEMBLAGE

ÉTAPE 5:

Déployez le couvercle supérieur (6) et fixez-le avec 4 vis hexagonales plates M6 (C).

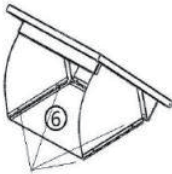

ÉTAPE 6:

Placez le couvercle supérieur (6) sur le cadre et fixez-le avec 2 vis cruciformes M5 (B) et 2 écrous M5 (A).

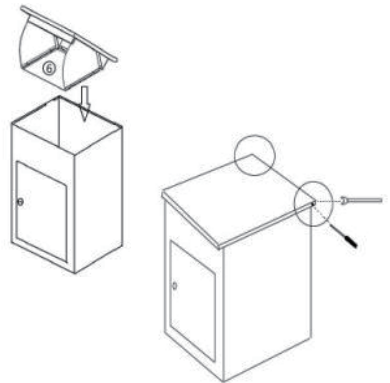

ÉTAPE 7:

Fixer les entretoises (7) aux panneaux latéraux (2) et les maintenir en place avec 2 écrous M6 (D).

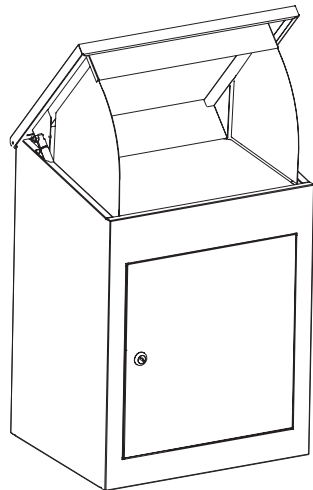
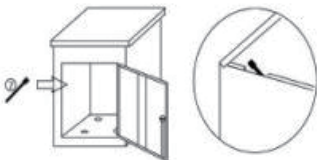

MODE D'EMPLOI

INSTRUCTIONS D'INSTALLATION

INSTALLATION MURALE

ÉTAPE 1:

Placez la boîte aux lettres sur le mur à l'emplacement souhaité et marquez l'endroit où les trous doivent être percés.

ÉTAPE 2:

Retirez la boîte du mur et percez les trous aux endroits marqués à l'aide d'une mèche de 10 mm. Insérez les 4 chevilles murales (G) dans les trous percés.

ÉTAPE 3:

Repositionnez la boîte et insérez les 4 rondelles M8x16 mm (I) et les 4 boulons hexagonaux M8x50 mm dans les trous de la et fixez-les solidement au mur.

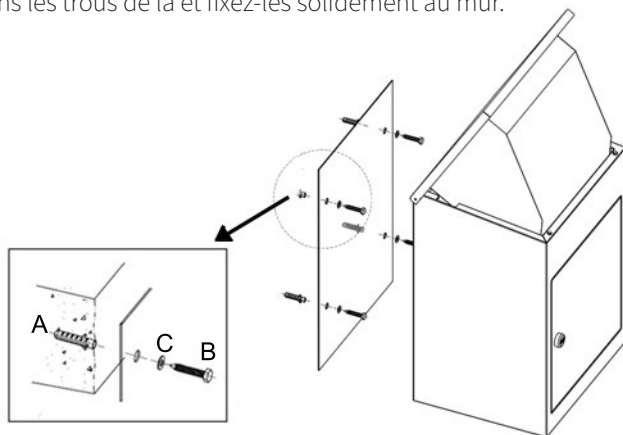

INSTALLATION AU SOL

Si vous installez la boîte aux lettres pour colis au sol, vérifiez toute absence de tuyaux ou de câbles souterrains avant de percer.

Répétez le même processus que ci-dessus, en veillant à utiliser une mèche adaptée à la surface du sol.

Utilisez les protections en caoutchouc fournies pour recouvrir les trous à l'arrière, et ce, afin de rendre la boîte étanche.

DÉPANNAGE

GUIDE DE RÉOLUTION

QUE FAIRE S'IL MANQUE DES PIÈCES À MA COMMANDE?

Si une pièce semble manquer à votre commande, veuillez contacter notre équipe du service client dans les 7 jours suivant la réception de votre commande.

**POUR TOUTE AUTRE DEMANDE, VEUILLEZ CONTACTER NOTRE
ÉQUIPE DU SERVICE CLIENT**



SPEZIFIKATIONEN

PRODUKT BESCHREIBUNG

Der intelligente Paketkasten von Monster Shop ist ein einfach zu bedienender, sicherer Briefkasten, in dem Ihre Pakete sicher aufbewahrt werden, während Sie nicht zu Hause sind. Dieser intelligente Briefkasten verfügt über einen Entnahmeschutz, so dass zugestellte Pakete ausschließlich aus dem Ablagefach entnommen werden können. Der intelligente Paketbriefkasten kann mehrere Lieferungen pro Tag annehmen. Wenn Sie zurückkommen, benutzen Sie einfach Ihren Zugangsschlüssel, um die Pakete abzuholen. Die Postbox verfügt über einen eindeutigen Barcode, der von Kurierdiensten gescannt oder aufgezeichnet und als Zustellnachweis verwendet werden kann, falls Ihre Lieferung dies erfordert.

PRODUKT SPEZIFIKATIONEN

ABMESSUNG:	44 x 35 x 57cm
MAX. PAKETGRÖSSE:	35 x 19 x 15cm
SCHLÜSSEL:	2

TEILELISTE



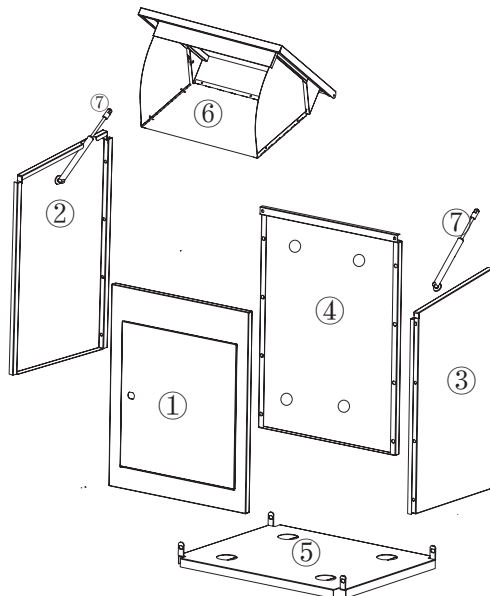



1. Frontplatte
2. Linke Seitenkonsole
3. Rechte Seitenkonsole
4. Rückwand
5. Unteres Bedienfeld
6. Obere Abdeckung
7. Deckelstreben





SPEZIFIKATION

PRODUKTMERKMALE

MONTAGEELEMENTE

Teil Nr.	Illustration	Beschreibung	Menge
A		M5 Mutter	X 2
B		M5 Kreuzschlitzschraube	X 2
C		M6 Flache Sechskantschraube	X 22
D		M6 Mutter	X 2
E		Inbusschlüssel	X 1
F		Schraubenschlüssel	X 1

BEFESTIGUNGSELEMENTE

Teil Nr.	Illustration	Beschreibung	Menge
G		M10x5mm Dübel	X 4
H		M8x50mm Sechskantschraube	X 4
I		M8x16mm Unterlegscheibe	X 4

Die Haftung von Monster Group UK Limited beschränkt sich ausschließlich auf den Handelswert des Produkts.

SICHERHEITSHINWEISE

SICHERES ARBEITSVERFAHREN

Bitte lesen Sie sich die Hinweise zum sicheren Arbeiten durch, um Verletzungen oder Schäden am Gerät zu vermeiden..

- Verwenden Sie dieses Produkt nicht für einen anderen als den vorgesehenen Zweck.
- Verändern oder modifizieren Sie dieses Produkt nicht in irgendeiner Weise.
- Halten Sie Ihren Arbeitsbereich frei von Unordnung.
- Sorgen Sie dafür, dass sich Kinder, Haustiere und unerfahrene Benutzer nicht in der Nähe aufhalten, wenn Sie diesen Paketkasten aufbauen.
- Überprüfen Sie das Produkt regelmäßig auf Schäden und Verschleißerscheinungen. Ziehen Sie alle Komponenten fest, die locker zu sein scheinen.
- Wir empfehlen, das Produkt mit zwei Personen zusammenzubauen.
- Prüfen Sie vor der Montage auf unterirdische Rohre oder Kabel.
- Bei der Montage des Briefkastens sollten Sie Handschuhe tragen.

GEBRAUCHSANLEITUNG

MONTAGEANLEITUNG

HINWEIS: Ziehen Sie die Schrauben erst dann fest, wenn der Zusammenbau abgeschlossen ist.

SCHRITT 1:

Befestigen Sie die Seitenteile (2) & (3) an der Frontplatte (1) und sichern Sie sie mit 6x M6 Flachsechskantschrauben (C).

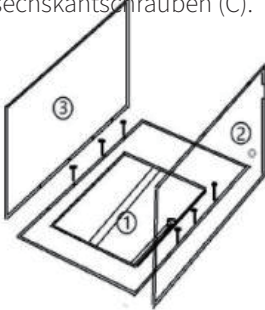

SCHRITT 2:

Stellen Sie den Rahmen aufrecht hin und befestigen Sie die Rückwand (4) mit 2x M6 Flachsechskant-Schrauben (C).

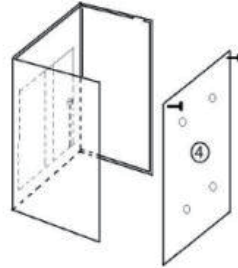

SCHRITT 3:

Befestigen Sie nun die Rückwand (4) von der Innenseite des Rahmens aus mit 6x M6-Flachsechskant-Schrauben (C).

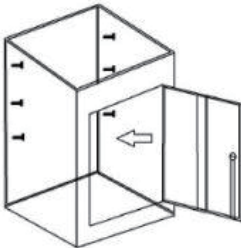

SCHRITT 4:

Setzen Sie nun die Bodenplatte (5) in den Rahmen ein. Befestigen Sie sie mit 4x M6 Flachsechskantschrauben (C).

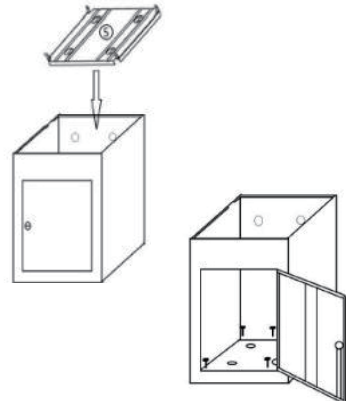

GEBRAUSANLEITUNG

MONTAGEANLEITUNG

SCHRITT 5:

Klappen Sie die obere Abdeckung (6) auf und befestigen Sie sie mit 4x M6 Flachsechskantschrauben (C).

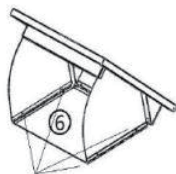

SCHRITT 6:

Setzen Sie die Obere Abdeckung (6) oben auf den Rahmen und befestigen Sie sie mit 2x M5 Kreuzschlitzschrauben (B) und 2x M5 Muttern (A).

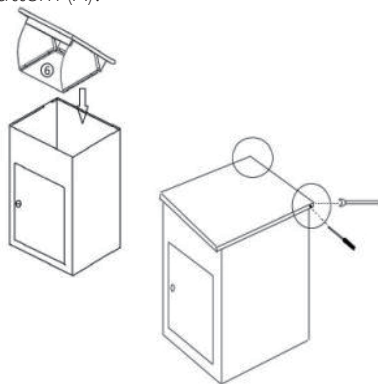

SCHRITT 7:

Befestigen Sie die Deckelstreben (7) an den Seitenteilen (2) und sichern Sie sie mit 2x M6-Muttern (D).

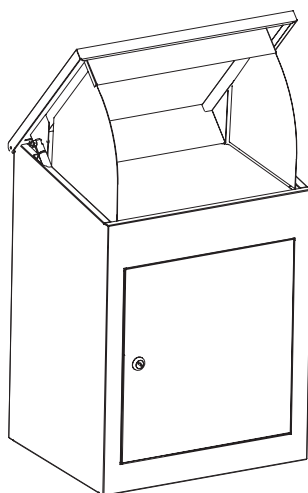
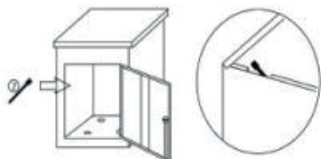

GEBRAUCHSANLEITUNG

MONTAGEANLEITUNG

WANDMONTAGE

SCHRITT 1:

Platzieren Sie den Paketkasten an der gewünschten Stelle an der Wand und markieren Sie, wo die Löcher gebohrt werden müssen.

SCHRITT 2:

Entfernen Sie den Paketkasten von der Wand und bohren Sie die Löcher an den markierten Stellen mit einem 10-mm-Bohrer. Setzen Sie die 4x Dübel (G) in die gebohrten Löcher ein.

SCHRITT 3:

Positionieren Sie den Paketkasten neu und stecken Sie die 4x M8x16mm Unterlegscheiben (I) und 4x M8x50mm Sechskantschrauben durch die Löcher im Inneren des Paketkastens und befestigen Sie ihn fest an der Wand.

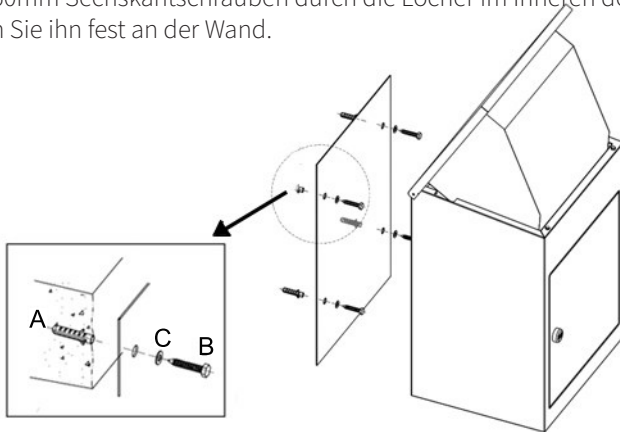

BODENMONTAGE

Wenn Sie die Paketbox in den Boden einbauen, prüfen Sie bitte vor dem Bohren, ob unterirdische Rohre oder Kabel vorhanden sind.

Führen Sie den gleichen Vorgang wie oben aus und stellen Sie sicher, dass Sie einen für die Bodenoberfläche geeigneten Bohrer verwenden.

Verwenden Sie die mitgelieferten Gummipads zum Abdecken der hinteren Löcher, um sicherzustellen, dass das System wasserdicht ist.

PROBLEMBEHANDLUNG

FEHLERBEHEBUNG

WAS KANN ICH TUN, WENN TEILE IN MEINER BESTELLUNG FEHLEN?

Sollte ein Teil in Ihrer Bestellung fehlen, wenden Sie sich bitte innerhalb von 7 Tagen nach Erhalt an unser freundliches und hilfsbereites Kundendienstteam.

FÜR ALLE ANDEREN FRAGEN WENDEN SIE SICH BITTE AN UNSEREN KUNDENDIENST.



ESPECIFICACIÓN

DESCRIPCIÓN DEL PRODUCTO

El buzón inteligente de Monster Shop es un buzón de entrega seguro y fácil de usar, que mantendrá sus paquetes seguros mientras esté fuera de casa. Este buzón inteligente cuenta con un diseño antirrobo para que los paquetes entregados sólo puedan recuperarse del compartimento de almacenamiento.

El buzón de paquetería inteligente puede aceptar varias entregas al día. A su regreso, sólo tiene que utilizar su llave de acceso para recuperar sus paquetes. El buzón proporciona un código de barras único que puede ser escaneado o registrado por los mensajeros y utilizado como prueba de entrega, en caso de que su entrega lo requiera.

ESPECIFICACIONES DEL PRODUCTO

DIMENSIONES:	44 x 35 x 57cm
TAMAÑO MAX DE PAQUETE:	35 x 19 x 15cm
LLAVES:	2

LISTA DE PIEZAS



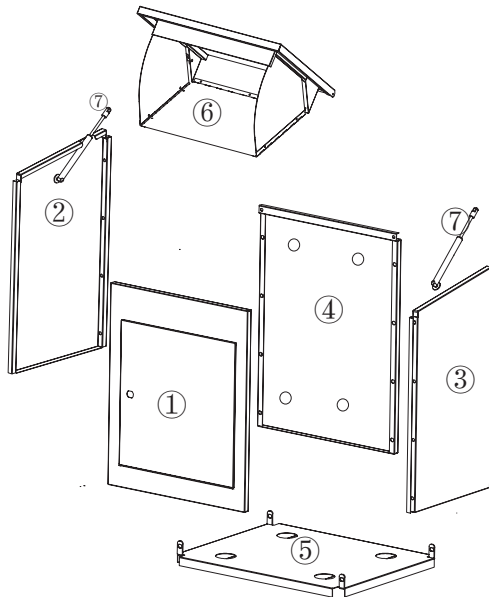



1. Panel frontal
2. Panel lateral izquierdo
3. Panel lateral derecho
4. Panel trasero
5. Panel inferior
6. Cubierta superior
7. Soportes de la tapa





ESPECIFICACIÓN

LISTA DE PIEZAS

FIJACIONES DE MONTAJE

Nº de pieza	Ilustración	Descripción	Cantidad
A		Tuerca M5	X 2
B		Tornillo de cabeza en cruz M5	X 2
C		Tornillo hexagonal plano M6	X 22
D		Tuerca M6	X 2
E		Llave hexagonal	X 1
F		Llave	X 1

FIJACIONES DE INSTALACIÓN

Nº de pieza	Ilustración	Descripción	Cantidad
G		Clavija de pared M10x5 mm	X 4
H		Tornillo hexagonal M8x50mm	X 4
I		Arandela M8x16mm	X 4

La responsabilidad de Monster Group UK Limited se limitará únicamente al valor comercial del producto.

CONSEJOS DE SEGURIDAD

PRÁCTICAS SEGURAS DE TRABAJO

Lea atentamente las Prácticas seguras de trabajo para evitar lesiones o daños al aparato.

- No utilice este producto para fines distintos de los previstos.
- No altere ni modifique este producto de ninguna forma.
- Mantenga la zona de trabajo despejada.
- Asegúrese de que no haya niños, mascotas/animales ni usuarios inexpertos en las inmediaciones cuando arme este buzón de paquetería.
- Inspeccione periódicamente el producto en busca de daños y signos de desgaste. Apriete cualquier componente que parezca estar suelto.
- Recomendamos que dos personas monten el producto.
- Si se instala en el suelo, compruebe si hay tuberías o cables subterráneos antes de instalarlo.
- Se debe utilizar guantes al montar el buzón.

GUÍA DEL USUARIO

INSTRUCCIONES DE MONTAJE

NOTA: Sólo apriete los tornillos a fondo una vez finalizado el montaje.

PASO 1:

Fije los paneles laterales (2) y (3) al panel frontal (1) y asegúrelos con 6 tornillos hexagonales planos M6 (C).

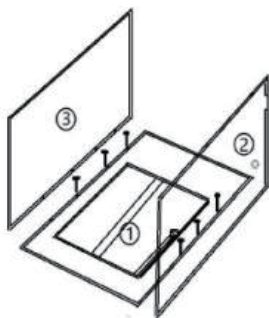

PASO 2:

Coloque la estructura en posición vertical y fije el panel trasero (4) con 2 tornillos hexagonales planos M6 (C).

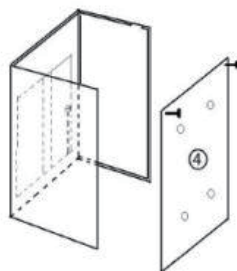

PASO 3:

Ahora fije el panel trasero (4) en su lugar desde el interior del marco utilizando 6x M6 tornillos hexagonales planos (C).

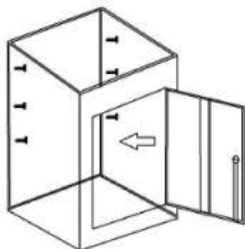

PASO 4:

Ahora fije el panel trasero (4) en su lugar desde el interior del marco utilizando 6x M6 tornillos hexagonales planos (C).

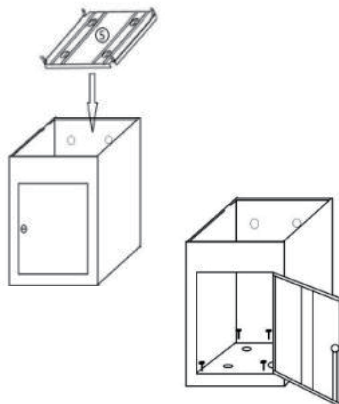

GUÍA DEL USUARIO

INSTRUCCIONES DE ENSAMBLAJE

PASO 5:

Despliegue la cubierta superior (6) y fíjela con 4 tornillos hexagonales planos M6 (C).

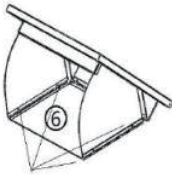

PASO 6:

Coloque la cubierta superior (6) sobre el bastidor y fíjela en su sitio con 2 tornillos de cabeza en cruz M5 (B) y 2 tuercas M5 (A).

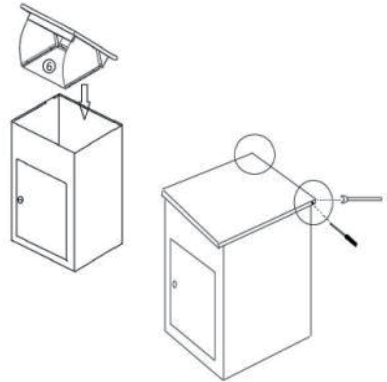

PASO 7:

Fije los soportes de la tapa (7) a los paneles laterales (2) y asegúrelos con 2 tuercas M6 (D).

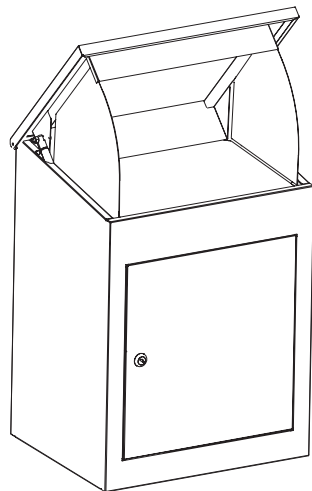
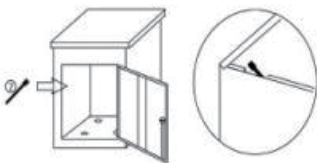

GUÍA DEL USUARIO

INSTRUCCIONES DE INSTALACIÓN

INSTALACIÓN EN PARED

PASO 1:

Coloque el buzón de paquetes en la pared en el lugar deseado y marque dónde hay que taladrar los agujeros.

PASO 2:

Retire el buzón de paquetes de la pared y taladre los agujeros en los lugares marcados con una broca de 10 mm. Inserte los 4 tacos (G) en los agujeros taladrados.

PASO 3:

Vuelva a colocar el buzón de paquetes e inserte las 4 arandelas M8x16mm (I) y los 4 tornillos hexagonales M8x50mm a través de los orificios del interior del buzón de paquetes y finalmente fíjelo a la pared.

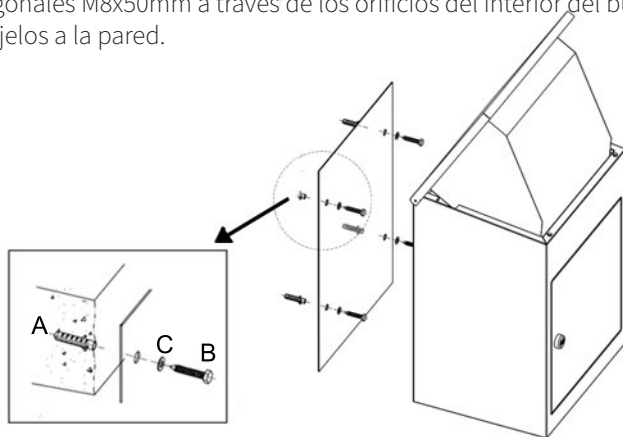

INSTALACIÓN EN SUELO

Si instala el buzón de paquetes en el suelo, compruebe si hay tuberías o cables subterráneos antes de taladrar.

Repita el mismo proceso anterior, asegurándose de utilizar una broca adecuada para la superficie del suelo.

Utilice las almohadillas de goma incluidas para cubrir los orificios traseros y garantizar la resistencia al agua.

SOLUCIÓN DE PROBLEMAS

GUÍA DE RESOLUCIÓN

¿QUÉ HAGO SI FALTAN PIEZAS EN MI PEDIDO?

Si parece que falta alguna pieza en su pedido, póngase en contacto con nuestro amable y servicial Equipo de Atención al Cliente en un plazo de 7 días a partir de la entrega.

**PARA CUALQUIER OTRO PROBLEMA, PÓNGASE EN CONTACTO
CON NUESTRO EQUIPO DE ATENCIÓN AL CLIENTE.**

SPECIFICHE

DESCRIZIONE DEL PRODOTTO

La cassetta postale intelligente di Monster Shop è sicura e facile da usare che manterrà i vostri pacchi al sicuro mentre siete lontani da casa. Questa cassetta postale intelligente è dotata di un design antifurto in modo che i pacchi consegnati possano essere recuperati solo dallo scomparto interno.

La cassetta postale intelligente può ricevere più consegne ogni giorno. Al vostro ritorno, usa semplicemente la vostra chiave di accesso e recupera i vostri pacchi. La cassetta fornisce un codice a barre univoco che può essere scansionato o annotato dai corrieri e utilizzato, se richiesto, come prova di consegna.

SPECIFICHE DEL PRODOTTO

DIMENSIONI:	44 x 35 x 57cm
DIM. MAX PACCO:	35 x 19 x 15cm
CHIAVI:	2

LISTA DEI COMPONENTI

1. Pannello anteriore
2. Pannello sinistro
3. Pannello destro
4. Pannello posteriore
5. Pannello inferiore
6. Coperchio superiore
7. Supporti del coperchio

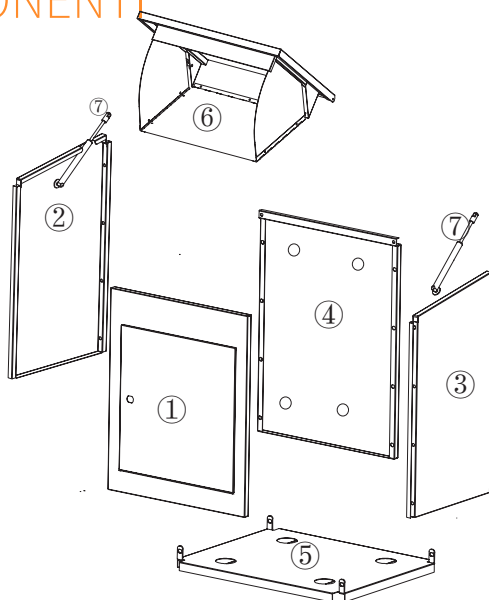



SPECIFICHE

LISTA DEI COMPONENTI

COMPONENTI PER IL MONTAGGIO

Codice	Illustrazione	Descrizione	Quantità
A		Dado M5	X 2
B		Vite a testa crociata M5	X 2
C		Vite con impronta esagonale M6	X 22
D		Dado M6	X 2
E		Brugola	X 1
F		Chiave inglese	X 1

COMPONENTI PER L'INSTALLAZIONE

Codice	Illustrazione	Descrizione	Quantità
G		Tassello M10x5mm	X 4
H		Dadi esagonali M8x50mm	X 4
I		Rondella M8x16mm	X 4

La responsabilità di Monster Group UK Limited sarà limitata al solo valore commerciale del prodotto.

CONSIGLI PER LA SICUREZZA

PROCEDURE DI UTILIZZO SICURO

Si prega di leggere le procedure di utilizzo sicuro per garantire la prevenzione di lesioni o danni al dispositivo.

- Non utilizzare questo dispositivo per scopi diversi da quelli previsti.
- Non alterare o modificare il prodotto in alcun modo.
- Mantenete l'area di assemblaggio libera dal disordine.
- Assicuratevi che bambini, animali domestici e utenti inesperti non siano nelle vicinanze durante la costruzione di questa cassetta per pacchi.
- Ispezionate regolarmente il prodotto per rilevare danni e segni di usura. Stringere tutti i componenti che sembrano essere allentati.
- Consigliamo di essere in due ad assemblare il prodotto.
- In caso di installazione al suolo, verificate la presenza di tubazioni o cavi sotterranei prima dell'installazione.
- Indossate dei guanti durante il montaggio della cassetta postale.

MANUALE DELL'UTENTE

ISTRUZIONI DI ASSEMBLAGGIO

NOTA: Serrate le viti completamente solo dopo aver terminato il montaggio.

STEP 1:

Unite i pannelli laterali (2) e (3) al pannello frontale (1) e fissarli con 6 viti a impronta esagonale M6 (C).

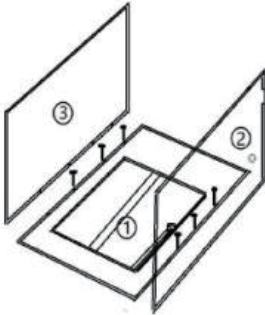

STEP 2:

Posizionate verticalmente la struttura e unite il pannello posteriore (4) usando 2 viti a impronta esagonale M6 (C).

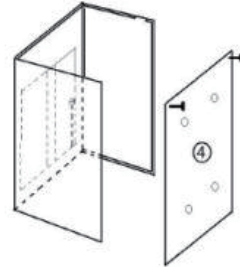

STEP 3:

Ora fissate il pannello posteriore (4) dall'interno della struttura utilizzando 6 viti a impronta esagonale M6 (C).

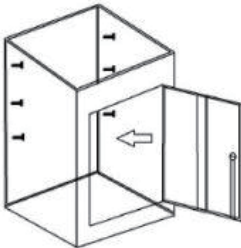

STEP 4:

Inserite il pannello inferiore (5) nella struttura. Avvitare usando 4 viti a impronta esagonale M6 (C).

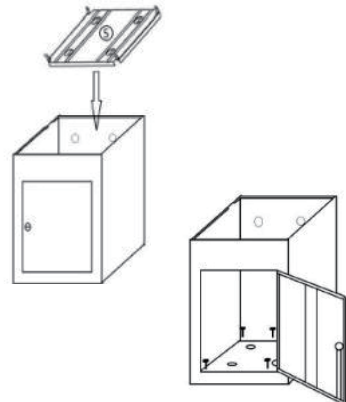

MANUALE DELL'UTENTE

ISTRUZIONI DI ASSEMBLAGGIO

STEP 5:

Aprire il coperchio superiore (6) e fissatelo con 4 viti a impronta esagonale M6 (C).

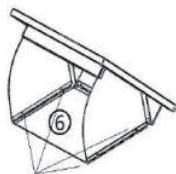

STEP 6:

Posizionare il coperchio (6) in cima alla struttura e fissarlo con 2 viti a impronta a croce (B) e 2 dadi M5 (A).

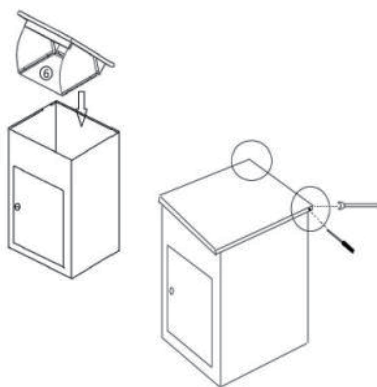

STEP 7:

Unite i supporti del coperchio (7) ai pannelli laterali (2) fissandoli con 2 dadi M6 (D).

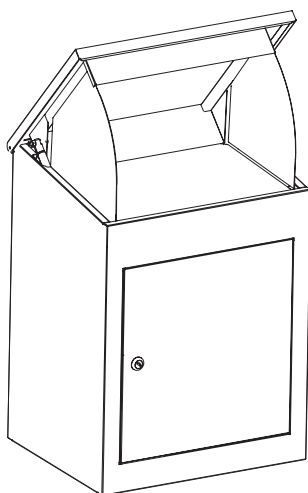
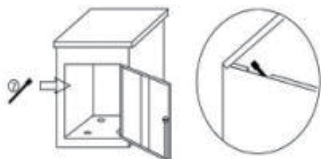

MANUALE DELL'UTENTE

ISTRUZIONI DI INSTALLAZIONE

INSTALLAZIONE A MURO

STEP 1:

Posizionate la cassetta postale a muro nella posizione desiderata e segnare dove devono essere forati i fori.

STEP 2:

Allontanate la cassetta dal muro e forate i fori nei punti contrassegnati usando un trapano con punta da 10mm. Inserite i 4 tasselli (G) nei fori appena forati.

STEP 3:

Riposizionate la cassetta e inserite 4 rondelle M8x16mm (I) e 4 viti a testa esagonale M8x50mm nei fori dentro la cassetta postale e fissate saldamente al muro.

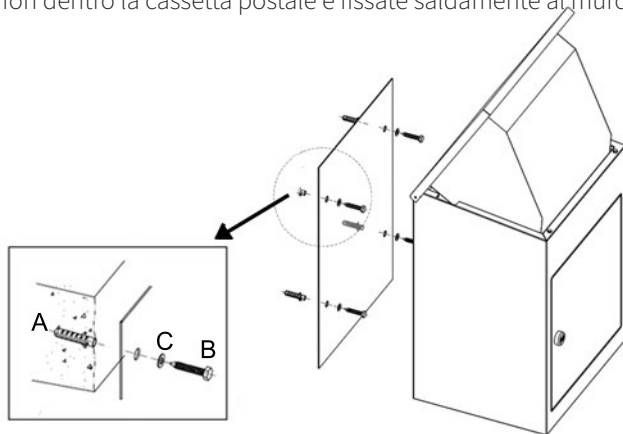

INSTALLAZIONE AL SUOLO

Se si installa la cassetta postale al suolo, verificate la presenza di tubi o cavi sotterranei prima di forare.

Ripetete lo stesso procedimento visto sopra, assicurandovi di utilizzare una punta da trapano appropriata per la superficie del terreno.

Utilizzate i gommini inclusi per coprire i fori posteriori per assicurarsi che siano impermeabili.

SOLUZIONE DEI PROBLEMI

GUIDA ALLA SOLUZIONE

COSA FACCIO SE MANCANO DEI COMPONENTI NEL MIO ORDINE?

Se mancano dei componenti nel vostro ordine, contattate il nostro team di assistenza clienti, cordiale e disponibile, entro 7 giorni dal ricevimento.

**PER TUTTI GLI ALTRI PROBLEMI, CONTATTATE IL NOSTRO
TEAM DI ASSISTENZA CLIENTI.**

SPECIFICATIE

PRODUCTOMSCHRIJVING

De Monster Shop Intelligente Brievenbus is een gebruiksvriendelijke, veilige brievenbus die je pakketten veilig bewaart wanneer je niet thuis bent. Deze slimme brievenbus heeft een anti-fishing ontwerp, zodat bezorgde pakketten alleen uit het bewaarcompartiment kunnen worden gehaald.

PRODUCTSPECIFICATIES

AFMETINGEN:	44 x 35 x 57cm
MAX. FORMAAT PAKKET:	35 x 19 x 15cm
SLEUTELS:	2

ONDERDELENLIJST

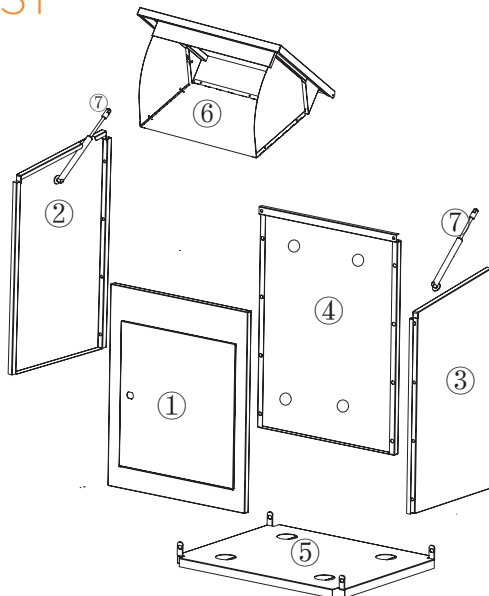

1. Voorpaneel
2. Linkerzijpaneel
3. Rechterzijpaneel
4. Achterpaneel
5. Onderpaneel
6. Bovenklep
7. Dekselsteunen





SPECIFICATIE

ONDERDELENLIJST

BENODIGDHEDEN VOOR MONTAGE

Onderd el nr.	Illustratie	Omschrijving	Aantal
A		M5 moer	X 2
B		M5 kruiskopschroef	X 2
C		M6 Platte zeshoekschroef	X 22
D		M6 moer	X 2
E		Inbussleutel	X 1
F		Moersleutel	X 1

BENODIGDHEDEN VOOR INSTALLATIE

Onderd el nr.	Illustratie	Omschrijving	Aantal
G		M10x5mm muurplug	X 4
H		M8x50mm zeskantbout	X 4
I		M8x16mm sluitring	X 4

De aansprakelijkheid van Monster Group UK Limited is beperkt tot alleen de commerciële waarde van het product.

VEILIGHEIDSADVIJES

VEILIG GEBRUIK

Lees het veiligheidsadvies door om letsel of schade aan het apparaat te voorkomen.

- Gebruik dit product niet voor iets anders dan waarvoor het bedoeld is.
- Verander of modificeer dit product op geen enkele manier.
- Houd de omgeving vrij van rommel.
- Zorg ervoor dat kinderen, (huis)dieren en onervaren gebruikers niet in de buurt zijn bij het plaatsen van deze brievenbus voor pakketjes.
- Inspecteer het product regelmatig op beschadigingen en tekenen van slijtage. Draai alle onderdelen die los lijken te zitten vast.
- We raden aan dat dit product door twee personen gemonteerd wordt.
- Controleer wanneer je dit product plaats voor de installatie of er ondergrondse leidingen of kabels aanwezig zijn.
- Draag handschoenen tijdens het plaatsen van de brievenbus.

HANDLEIDING

MONTAGEINSTRUCTIES

LET OP: Draai de schroeven pas volledig vast als de montage voltooid is.

STAP 1:

Bevestig de zijpanelen (2) en (3) aan het voorpaneel (1) en zet ze vast met 6x M6 platte zeskantschroeven (C).

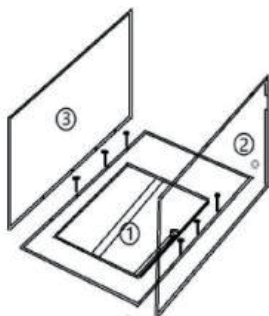

STAP 2:

Zet het ingebouwde frame rechtop en bevestig het achterpaneel (4) met 2x M6 platte zeskantschroeven (C).

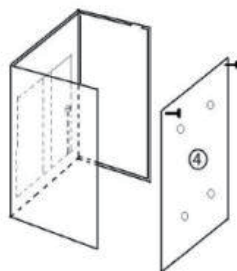

STAP 3:

Bevestig nu het achterpaneel (4) op zijn plaats vanaf de binnenkant van het frame met behulp van 6x M6 platte zeskantschroeven (C).

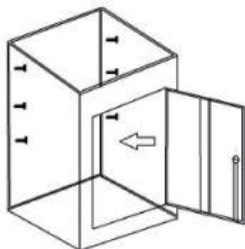

STAP 4:

Plaats nu het bodempaneel (5) in het frame. Zet vast met 4x M6 platte zeskantschroef (C).

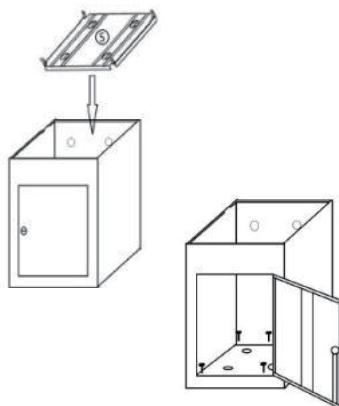

HANDLEIDING

MONTAGEINSTRUCTIES

STAP 5:

Open de bovenklep (6) open en zet vast met 4x M6 platte zeskantschroeven (C).

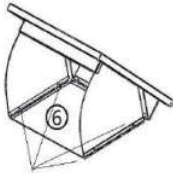

STAP 6:

Plaats de bovenkap (6) bovenop het frame en zet deze vast met 2x M5 kruiskopschroeven (B) en 2x M5 moeren (A).

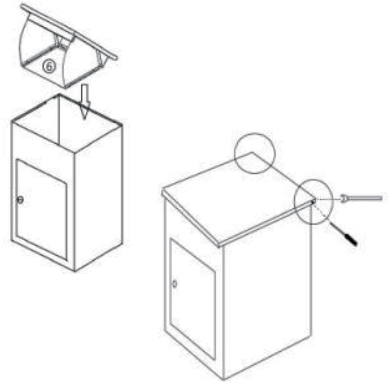

STAP 7:

Bevestig de dekselsteunen (7) aan de zijpanelen (2) en zet ze vast met 2x M6 Moeren (D).

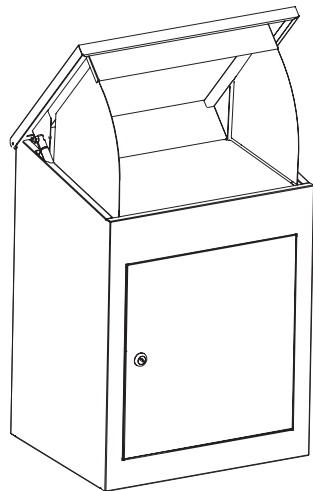
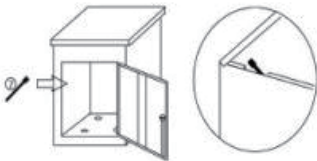

HANDLEIDING

MONTAGEINSTRUCTIES

BEVESTIGING AAN DE MUUR

STAP 1:

Plaats de pakket brievenbus op de gewenste plek aan de muur en teken af waar de gaten geboord moeten worden.

STAP 2:

Verwijder de pakket brievenbus van de muur en boor de gaten op de gemarkeerde plaatsen met een boor van 10 mm. Steek de 4x muurpluggen (G) in de geboorde gaten.

STAP 3:

Herpositioneer de pakket brievenbus en steek de 4x M8x16mm sluitringen (I) en 4x M8x50mm zeskantbouten door de gaten in de pakket brievenbus en bevestig ze stevig aan de muur.

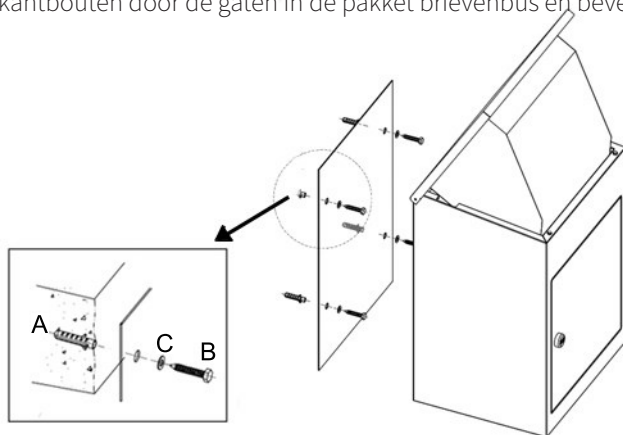

PLAATSING OP DE GROND

Wanneer je de pakket brievenbus op de grond plaats moet je voor het boren controleren of er geen ondergrondse leidingen of kabels aanwezig zijn.

Herhaal het hierboven vermelde proces en zorg ervoor dat je een boor gebruikt die geschikt is voor het grondoppervlak.

Gebruik de meegeleverde rubberen onderdeeljes om de achterste gaten te bedekken en ze waterdicht te maken.

OPLOSSEN VAN PROBLEMEN

OPLOSSINGEN

WAT MOET IK DOEN ALS ER ONDERDELEN VAN MIJN BESTELLING ONTBREKEN?

Neem wanneer er een onderdeel van je bestelling lijkt te ontbreken binnen 7 dagen na ontvangst contact op met ons vriendelijke en behulpzame klantenservice.

**NEEM VOOR ALLE OVERIGE PROBLEMEN CONTACT OP MET
ONZE KLANTENSERVICE.**



SPECIFIKATION

PRODUKTBESKRIVNING

Monster Shops smarta postlåda är en lättanvänd, säker leveranspostlåda som håller dina paket säkra när du är borta från hemmet. Denna smarta postlåda har en anti-fiske-design så att levererade paket endast kan hämtas från förvaringsfacket.

Enheten kan ta emot flera leveranser varje dag. När du kommer tillbaka använder du helt enkelt din åtkomstnyckel för att hämta dina paket. Postlådan förser en unik streckkod som kan skannas eller registreras av kurirer och användas som leveransbevis, om din leverans skulle kräva det.

PRODUKTSPECIFIKATIONER

MÅTT:	44 x 35 x 57cm
MAX PAKETSTORLEK:	35 x 19 x 15cm
NYCKLAR:	2

DELLISTA



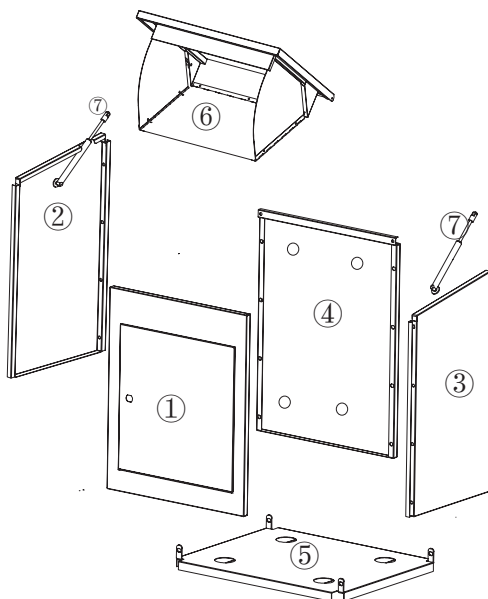



1. Frontpanel
2. Vänster sidopanel
3. Höger sidopanel
4. Bakpanel
5. Bottenpanel
6. Topplock
7. Lås





SPECIFIKATION

DELLISTA

MONTERINGSFÄSTNINGAR

Del Nr.	Illustration	Beskrivning	Kvantitet
A		M5 Mutter	X 2
B		M5 Cross Head Skruv	X 2
C		M6 platt sexkantsskruv	X 22
D		M6 Mutter	X 2
E		Insexnyckel	X 1
F		Skiftnyckel	X 1

INSTALLATIONSFÄSTNINGAR

Del Nr.	Illustration	Beskrivning	Kvantitet
G		M10x5mm väggkontakt	X 4
H		M8x50mm sexkantsbult	X 4
I		M8x16mm bricka	X 4

Monster Group UK Limiteds ansvar är begränsat till produktens kommersiella värde.

SÄKERHETSÅD

SÅKER ARBETSÅRAXIS

Vånligen läs igenom SÅKER ARBETSÅRAXIS för att säkerställa förebyggande av skador eller skador på enheten.

- Använd inte denna produkt för något annat än dess avsedda ändamål.
- Åndra eller modifiera inte denna produkt på något sätt.
- Håll ditt byggområde fritt från skräp.
- Se till att barn, husdjur/djur och oerfarna användare inte finns i nærheten när du bygger denna paketbrevlåda.
- Inspektera regelbundet produkten för skador och tecken på slitage. Dra åt alla komponenter som verkar vara lösa.
- Vi rekommenderar två personer att montera produkten.
- Om du installerar på marken, kontrollera om det finns underjordiska rör eller kablar innan du installerar.
- Handskar ska användas vid montering av postlådan.

ANVÄNDARGUIDE

MONTERINGSANVISNINGAR

OBS: Dra åt skruvarna helt när monteringen är klar.

STEG 1:

Fäst sidopanelerna (2) och (3) på frontpanelen (1) och fäst med 6x M6 platta sexkantsskruvar (C).

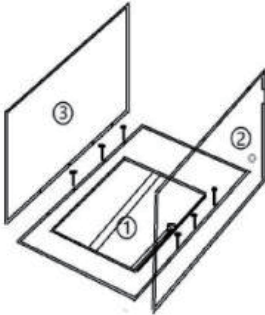

STEG 2:

Ställ den byggda ramen upprätt och fäst den bakre panelen (4) med 2x M6 platta sexkantsskruvar (C).

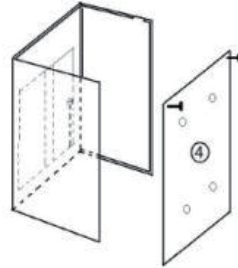

STEG 3:

Fäst nu bakpanelen (4) på plats från insidan av ramen med 6x M6 platta sexkantsskruvar (C).

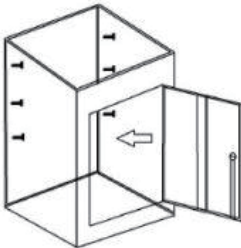

STEG 4:

Placera nu bottenpanelen (5) i ramen. Säkra på plats med 4x M6 platta sexkantsskruvar (C).

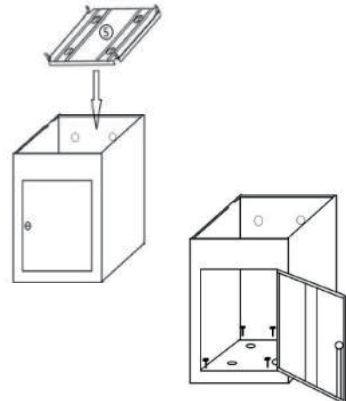

ANVÄNDARGUIDE

MONTERINGSANVISNINGAR

STEG 5:

Vik upp topplocket (6) och fäst med 4x M6 platta sexkantsskruvar (C).

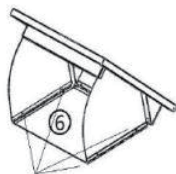

STEG 6:

Placera topplocket (6) ovanpå ramen och fäst med 2x M5 Cross Head-skruvar (B) och 2x M5 Muttrar (A).

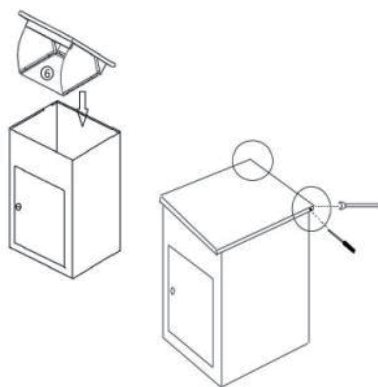

STEG 7:

Fäst lockstagen (7) på sidopanelerna (2) och fäst dem på plats med 2x M6 muttrar (D).

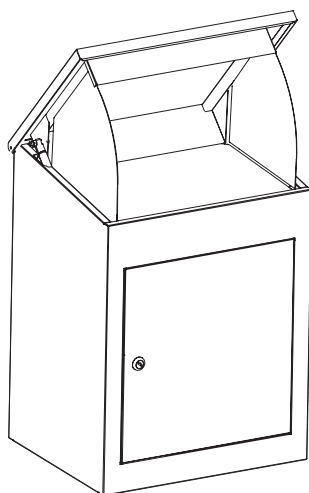
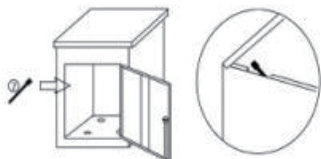

ANVÄNDARGUIDE

INSTALLATIONSINSTRUKTIONER

VÄGGINSTALLATION

STEG 1:

Placera paketpostlådan på väggen på önskad plats och markera var hålen ska borraras.

STEG 2:

Ta bort paketpostlådan från väggen och borra hålen på de markerade platserna med en 10 mm borrh. Sätt i 4x väggpluggarna (G) i de borrarade hålen.

STEG 3:

Sätt tillbaka paketpostlådan och sätt in 4x M8x16mm brickor (I) och 4x M8x50mm sexkantsbultar genom hålen inuti paketpostlådan och fäst dem ordentligt på väggen.

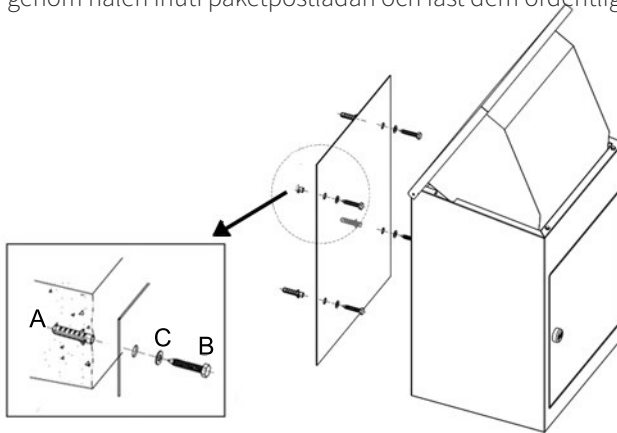

MARKINSTALLATION

Om du installerar paketpostlådan på marken, kontrollera efter underjordiska rör eller kablar innan du borrar.

Upprepa samma process som ovan och se till att du använder en lämplig borrh för markytan.

Använd de medföljande gummikuddarna för att täcka de bakre hålen för att säkerställa att den är vattentät.

FELSÖKNING

LÖSNINGSGUIDE

VAD GÖR JAG OM DET SAKNAS DELAR I MIN BESTÄLLNING?

Om det verkar saknas någon del i din beställning, kontakta vårt vänliga och hjälpsamma kundsupportteam inom 7 dagar efter mottagandet.

**FÖR ALLA ANDRA FRÅGOR, KONTAKTA VÅRT
KUNDSUPPORTTEAM.**

Monster Group (UK) is one of the UK's fastest growing online retailers. We supply a diverse range of products which offer exceptional value for money. We strive to provide the best possible customer experience with free UK delivery across all our products and a Monster Guarantee for 100% satisfaction.

For information regarding this device or other products from our Monster divisions please contact Sales.

SALES

TEL: 01347 878 888

EMAIL: hello@monstershop.co.uk

For queries about this device, warranty, returns or reporting faults please contact Support.

SUPPORT

TEL: 01347 878 887

EMAIL: help@monstershop.co.uk

Pour plus d'informations concernant cet appareil ou d'autres produits de nos divisions de Monster veuillez utiliser les détails suivants ci-dessous.

DÉPARTEMENT COMMERCIAL

TEL: 01347 878 888

EMAIL: bonjour@monstershop.eu

Pour les interrogations concernant cet appareil, la garantie, les retours ou les défauts de déclaration veuillez utiliser les détails suivants ci-dessous.

DÉPARTEMENT DE SOUTIEN

TEL: 01347 878 887

EMAIL: help@monstershop.co.uk

Para información sobre este dispositivo u otros productos de nuestras divisiones de Monster por favor use los siguientes detalles.

DEPARTAMENTO DE VENTAS

TEL: 01347 878 888

EMAIL: hola@monstershop.eu

Para consultas sobre este dispositivo, la garantía, devoluciones o denuncias de fallos por favor use los siguientes detalles.

DEPARTAMENTO DE SOPORTE

TEL: 01347 878 887

EMAIL: help@monstershop.co.uk

Für Informationen bezüglich dieses Geräts oder anderer Produkte aus unserer Monster-Abteilung, benutzen sie die folgenden unten aufgeführten Angaben.

VERKAUFABTEILUNG

TEL: 01347 878 888

EMAIL: hallo@monstershop.eu

Für Fragen über dieses Gerät, die Garantie, Rückgaben oder bei Störungen, benutzen sie die folgenden unten aufgeführten Angaben.

SUPPORT-ABTEILUNG

TEL: 01347 878 887

EMAIL: help@monstershop.co.uk

Per informazioni riguardanti questo dispositivo o altri prodotti dalle categorie Monster utilizzare i dettagli sotto riportati.

DIPARTIMENTO VENDITE

TEL: 01347 878 888

EMAIL: ciao@monstershop.eu

Per domande riguardo dispositivo, garanzia, reso o per riferire di guasti, utilizzare i dettagli sotto riportati.

DIPARTIMENTO SUPPORTO

TEL: 01347 878 887

EMAIL: help@monstershop.co.uk

Monster House, Alan Farnaby Way,
Sheriff Hutton Industrial Estate,
Sheriff Hutton, York, YO60 6PG
www.monstershop.co.uk



 Try **Monster**. Buy **Monster**. Be **Monster**. 