

6ft x 6ft Polycarbonate Greenhouse

210609 / 210619

INSTRUCTION MANUAL

www.monstershop.co.uk

SPECIFICATION

SPÉCIFICATIONS/ SPEZIFIKATIONEN/ ESPECIFICACIONES/ SPECIFICHE/ OMSCHRIJVING/ SPECIFIKATION

PRODUCT DESCRIPTION

DESCRIPTION DU PRODUIT/ PRODUKTBESCHREIBUNG/ DESCRIPCIÓN DEL PRODUCTO/ DESCRIZIONE DEL PRODOTTO/ PRODUCT OMSCHRIJVING/ PRODUKTBESKRIVNING



This glorious greenhouse is constructed with a thick aluminium frame and high-density polycarbonate sheets. The rustproof, aluminium frame is a solid structure made to withstand wind and other adverse weather conditions. Allow your plants and vegetables to breath with the handy window located at the top of the unit.



Cette magnifique serre est constituée d'un cadre en aluminium épais et de panneaux en polycarbonate haute densité. Le cadre en aluminium antirouille est la structure solide conçue pour résister au vent et autres conditions capricieuses de la météo. Laissez vos plantes et légumes respirer grâce à la fenêtre pratique située dans la partie supérieure de la serre.



Dieses fantastische Gewächshaus ist aus einem starkem Aluminiumrahmen und Polycarbonatplatten mit hoher Dichte gefertigt. Der robuste, rostfreie Aluminiumrahmen wurde mit maximaler Widerstandsfähigkeit gegen alle schlechten Wetterbedingungen entwickelt. Das praktische Fenster an der Oberseite des Geräts versorgt Ihre Pflanzen und Ihr Gemüse mit frischer Luft.



Este glorioso invernadero está construido con un marco de aluminio grueso y láminas de policarbonato de alta densidad. El marco de aluminio inoxidable es una estructura sólida hecha para soportar el viento y otras condiciones climáticas adversas. Permita que sus plantas y vegetales respiren con la práctica ventana ubicada en la parte superior de la unidad.

SPECIFICATION

SPÉCIFICATIONS/ SPEZIFIKATIONEN/ ESPECIFICACIONES/ SPECIFICHE/
OMSCHRIJVING/ SPECIFIKATION



Questa gloriosa serra è costruita con uno spesso telaio in alluminio e lastre di policarbonato ad alta densità. Il telaio in alluminio antiruggine è una solida struttura realizzata per resistere al vento e ad altre condizioni atmosferiche avverse. Consenti alle tue piante e verdure di respirare con la pratica finestra situata nella parte superiore dell'unità.



Dit glorieuze broeikas is gebouwd met een dik aluminium frame en polycarbonaatplaten met hoge dichtheid. Het roestvrije, aluminium frame is een stevig structuur die bestand is tegen wind en andere ongunstige weersomstandigheden. Laat je planten en groenten ademen met het handige venster aan de bovenkant van dit apparaat.



Detta härliga växthus är konstruerat med en tjock aluminiumram och polycarbonatrutor med hög densitet. Den rostfria aluminiumramen är en solid struktur som är gjord för att motstå vind och andra ogynnsamma väderförhållanden. Låt dina växter och grönsaker andas genom det praktiska fönstret som är placerat högst upp på växthuset.

SPECIFICATION

SPÉCIFICATIONS/ SPEZIFIKATIONEN/ ESPECIFICACIONES/ SPECIFICHE/
OMSCHRIJVING/ SPECIFIKATION

PRODUCT SPECIFICS

DÉTAILS DU PRODUIT/ PRODUKTSPEZIFIKA/ ESPECIFICACIONES DEL PRODUCTO/
SPECIFICHE DEL PRODOTTO/ PRODUCTSPECIFICATIES/ PRODUKTSPEZIFIKATIONER







	DIMENSIONS / DIMENSIONS / ABMESSUNG / DIMENSIONES / DIMENSIONI / DIMENSIES / MÅTT (cm)	FRAME MATERIAL / MATERIEL CADRE / RAHMENMATERIAL / MATERIAL DEL MARCO / MATERIALE DEL TELAIO / FRAME MATERIAAL / RAMMATERIAL	PANEL MATERIAL / MATERIEL PANNEAU / PLATTENMATERIAL / MATERIALES DE PANELES / MATERIALE DEL PANNELLO / PANEEL MATERIAAL / PANELMATERIAL
	189 (W) x 182.5 (L)	Powder Coated Aluminum / Galvanised Aluminum	Polycarbonate
	189 (I) x 182.5 (L)	Aluminium enduit de poudre / Aluminium Galvanisé	Polycarbonate
	189 (B) x 182.5 (L)	Pulverbeschichtetes Aluminium / Verzinktes Aluminium	Polycarbonat
	189 (An) x 182.5 (L)	Aluminio con Recubrimiento en polvo / Aluminio Galvanizado	Policarbonato
	189 (La) x 182.5 (L)	Alluminio Verniciato a polvere/ Alluminio Zincato	Policarbonato
	189 (B) x 182.5 (L)	Gepoedercoat Aluminium / Gegalvaniseerd Aluminium	Polycarbonaat
	189 (B) x 182.5 (L)	Pulverlakerad Aluminium / Galvaniserad Aluminium	Polykarbonat

SPECIFICATION

SPÉCIFICATIONS/ SPEZIFIKATIONEN/ ESPECIFICACIONES/ SPECIFICHE/
OMSCHRIJVING/ SPECIFIKATION

PRODUCT SPECIFICS

DÉTAILS DU PRODUIT/ PRODUKTSPEZIFIKA/ ESPECIFICACIONES DEL PRODUCTO/
SPECIFICHE DEL PRODOTTO/ PRODUCTSPECIFICATIES/ PRODUKTSPEZIFIKATIONER

	DOOR DIMENSIONS / DIMENSIONS PORTE / TÜRMAßE / DIMENSIONES DE LA PUERTA / DIMENSIONI DELLA PORTA / AFMETINGEN DEUR / DÖRR-MÅTT (cm)	WINDOW DIMENSIONS / DIMENSIONS FENETRE / FENSTERMAßE / DIMENSIONES DE LA VENTANA / DIMENSIONI FINESTRA / RAAM AFMETINGEN / FÖNSTER-MÅTT (cm)	MAX WINDOW OPENING / OUVERTURE MAXIMALE FENETRE / MAX. FENSTERÖFFNUNG / APERTURA MÁXIMA DE VENTANA / APERTURA MASSIMA DELLA FINESTRA / MAX RAAMOPENING / MAX FÖNSTERÖPPNING (cm)
	168.5 (H) x 63 (W)	59 (W) x 61 (L)	26.5
	168.5 (H) x 63 (l)	59 (l) x 61 (L)	26.5
	168.5 (L) x 63 (B)	59 (B) x 61 (L)	26.5
	168.5 (Al) x 63 (An)	59 (An) x 61 (L)	26.5
	168.5 (Al) x 63 (La)	59 (La) x 61 (L)	26.5
	168.5 (H) x 63 (B)	59 (B) x 61 (L)	26.5
	168.5 (H) x 63 (B)	59 (B) x 61 (L)	26.5

SPECIFICATION

SPÉCIFICATIONS/ SPEZIFIKATIONEN/ ESPECIFICACIONES/ SPECIFICHE/
OMSCHRIJVING/ SPECIFIKATION

PRODUCT FEATURES

CARACTÉRISTIQUES DU PRODUIT/ PRODUKTMERKMALE/ CARACTERÍSTICAS
DEL PRODUCTO/ CARATTERISTICHE DEL PRODOTTO/ PRODUCT SPECIFICATIE/
PRODUKTFUNKTIONER

- A. **Powder Coated Aluminium or Galvanised Aluminium Frame** / Cadre en aluminium enduit de poudre ou Aluminium galvanisé / Pulverbeschichteter Aluminium rahmen oder Verzinktes Aluminium / Marco de aluminio con recubrimiento en polvo o Aluminio galvanizado / Telaio in alluminio verniciato a polvere o alluminio zincato/ Gepoedercoat aluminium of Gegalvaniseerd aluminium / Pulverlackerad aluminiumram eller Galvaniserad aluminiumram.
- B. **Twin Wall Polycarbonate Glazing** / Vitrage en polycarbonate à double paroi / Doppelwandige Polycarbonatverglasung / Acristalamiento de policarbonato de pared doble / Vetri in policarbonato a doppia parete / Twin Wall Polycarbonaat beglazing / Dubbelfönster i polykarbonat.
- C. **Roof Window** / Fenêtre vélux / Dachfenster / Ventana de techo / Finestra sul tetto / Dakraam / Takfönster.
- D. **Hinged Door with Lock** / Porte avec serrure / Flügeltür mit Schloss / Puerta batiente con cerradura / Porta a battente con serratura / Scharnierende deur met slot / Gångjärnsdörr med lås.
- E. **Steel Base** / Base en acier / Stahlbasis / Base de acero / Base in acciaio / Stalen onderstel / Stålbas.
- F. **Apex Roof** / Faîtage / Satteldach / Techo de ápice / Tetto Apice / Apex Dak / Apex Tak.
- G. **Gutters** / Gouttières / Dachrinnen / Canalones / Grondaie / Dakgoten / Takränna.

Monster Group UK Limited's liability will be limited to the commercial value of the product only.

SPECIFICATION

SPÉCIFICATIONS/ SPEZIFIKATIONEN/ ESPECIFICACIONES/ SPECIFICHE/
OMSCHRIJVING/ SPECIFIKATION

PRODUCT FEATURES

CARACTÉRISTIQUES DU PRODUIT / PRODUKTMERKMALE / CARACTERÍSTICAS
DEL PRODUCTO / CARATTERISTICHE DEL PRODOTTO / PRODUCT SPECIFICATIE
/ PRODUKTFUNKTIONER

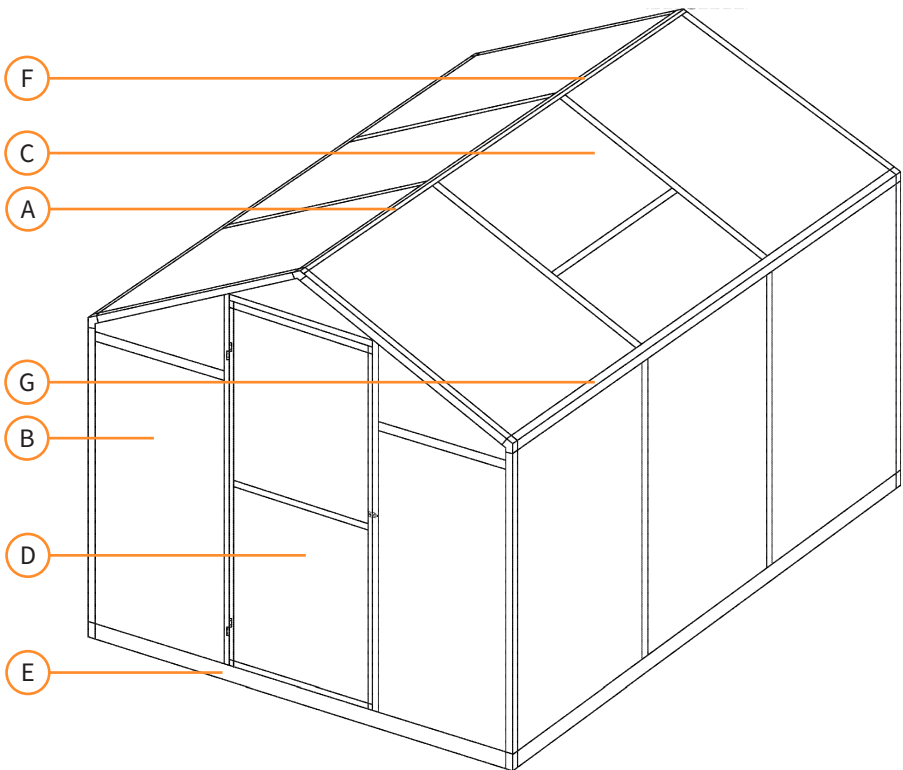

SPECIFICATION

**PARTS LIST / COMPOSANTS / TEILELISTE / LISTA DE PARTES /
CONTENUTO / ONDERDELENLIJST / DELLISTA**



When first unpacking your greenhouse, check each part against this list to ensure that they are all present. Each part is clearly labelled. If any are missing contact us before attempting to assemble.



Lors du premier déballage de votre serre, vérifiez chaque pièce par rapport à cette liste pour vous assurer qu'elles sont toutes présentes. Chaque partie est clairement étiquetée. S'il en manque, contactez-nous avant d'essayer d'assembler.



Wenn Sie Ihr Gewächshaus zum ersten Mal auspacken, überprüfen Sie jedes Teil anhand dieser Liste, um sicherzustellen, dass alle Teile vorhanden sind. Jedes Teil ist eindeutig beschriftet. Wenn etwas fehlt, kontaktieren Sie uns, bevor Sie versuchen, es zusammenzubauen



Cuando desempaque su invernadero por primera vez, verifique cada parte con esta lista para asegurarse de que estén todas presentes. Cada parte está claramente etiquetada. Si falta alguno, póngase en contacto con nosotros antes de intentar montar.



Quando disimballi la tua serra per la prima volta, controlla ogni parte rispetto a questo elenco per assicurarti che siano tutte presenti. Ogni parte è chiaramente etichettata. Se ne mancano contattateci prima di tentare il montaggio.



Wanneer u uw kas voor het eerst uitpakt, controleert u elk onderdeel aan de hand van deze lijst om er zeker van te zijn dat ze allemaal aanwezig zijn. Elk onderdeel is duidelijk gelabeld. Als er iets ontbreekt, neem dan contact met ons op voordat u probeert te monteren.





När du först packar upp ditt växthus, kontrollera varje del mot denna lista för att säkerställa att de alla är närvarande. Varje del är tydligt märkt. Om någon saknas kontakta oss innan du försöker montera.

SPECIFICATION

PARTS LIST / COMPOSANTS / TEILELISTE / LISTA DE PARTES /
CONTENUTO / ONDERDELENLIJST / DELLISTA

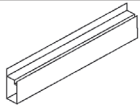
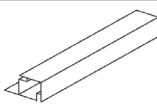
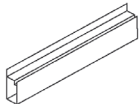
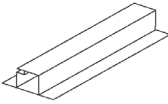
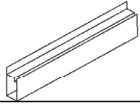
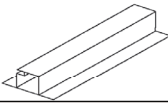
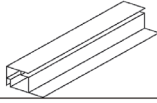
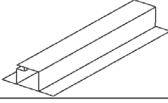
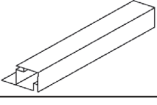
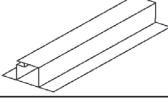
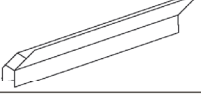
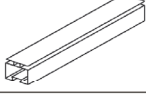

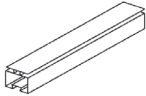
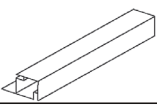
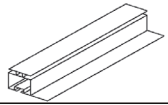
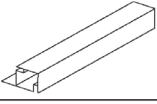
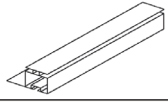
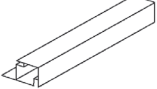
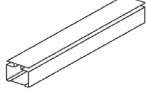



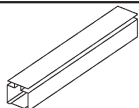

FRAME / CADRE / RAHMEN / CUADRO / TELAIO / KADER / RAM

No.	Picture	Qty.	Size	No.	Picture	Qty.	Size
1		2	176.2	11		1	97.5
3		1	172	12		1	168.2
4		1	172	13		1	168.2
5A		2	133.2	14		1	170.2
5B		2	133.2	15		1	170.2
6		1	176.2	16		4	133.2
7		1	176.2	17		2	99
8		1	97.5	18A		1	98.6
9		1	97.5	18B		1	98.6
10		1	97.5	19		2	52.2

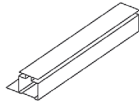
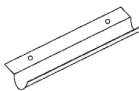
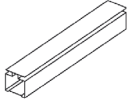
SPECIFICATION

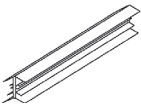
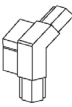
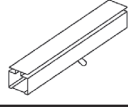
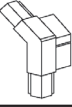
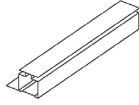
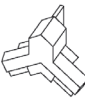
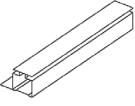
PARTS LIST / COMPOSANTS / TEILELISTE / LISTA DE PARTES /
CONTENUTO / ONDERDELENLIJST / DELLISTA

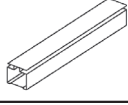

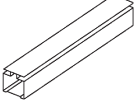

FRAME / CADRE / RAHMEN / CUADRO / TELAIO / KADER / RAM

No.	Picture	Qty.	Size	No.	Picture	Qty.	Size
20		2	55.1	30	 window	1	58*58
21		1	63	31		2	176.2
22		1	57	32		4	
23		1	176.2	33A		2	
24		1	57.2	33B		2	
25		1	159	34		2	
26		1	159	35A		2	
27		2	56	35B		2	
28		1	56				



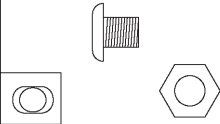
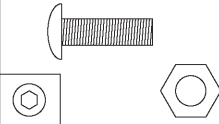
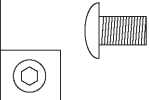

SPECIFICATION

PARTS LIST / COMPOSANTS / TEILELISTE / LISTA DE PARTES / CONTENUTO / ONDERDELENLIJST / DELLISTA

NUTS & BOLTS / ECROUS ET BOULONS / SCHRAUBEN & MUTTERN / TUERCAS Y
TORNILLOS / DADI E BULLONI / MOEREN & BOUTEN / MUTTRAR & BULTAR

No.	Picture	Qty.	Size	No.	Picture	Qty.	Size
41		12	M6*9	44		2	M6*26
42		56	M6*12	Allen Key			
43		16	M4*8	Spanner			





GROUND ANCHOR / ANCRAGE AU SOL / BODENANKER / ANCLAJE DE TIERRA /
ANCORA A TERRA / GRONDANKER / JORDANKARE

No.	Picture	Qty.
48		4
51A		4
51		4
52		1

SPECIFICATION

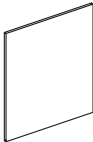
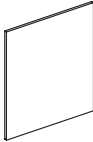
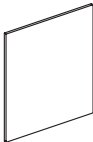
PARTS LIST / COMPOSANTS / TEILELISTE / LISTA DE PARTES /
CONTENUTO / ONDERDELENLIJST / DELLISTA

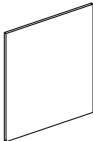
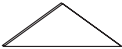
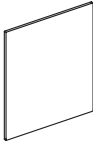
POLYCARBONATE WINDOWS / FENETRE EN POLYCARBONATE / POLYCARBONAT FEN-
STER / VENTANAS DE POLICARBONATO / FINESTRE IN POLICARBONATO / POLYCARBO-
NAAT RAMEN / POLYKARBONATFÖNSTER

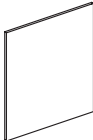
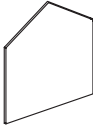
No.	Picture	Qty.	Size	No.	Picture	Qty.	Size
A		6	136*58.7	G		2	132.7*54
B		5	102*58.7	H		2	34.8*54 *3.7
C		2	132.7*56.9	I		1	20*63 *1.2
D		1	132.7*58.8	J		1	39.8*58.7
E		2	37*56.9 *3.7	K		2	79.8*57.6
F		1	55*58.8				

SAFETY ADVICE

CONSEILS DE SÉCURITÉ/ SICHERHEITSHINWEIS/ CONSEJOS DE SEGURIDAD/
CONSIGLI PER LA SICUREZZA/ VEILIGHEIDSADVIIES/ SÄKERHETSÅD

SAFE WORKING PRACTICE

PRATIQUE DE TRAVAIL SÉCURITAIRE/ SICHERES ARBEITEN/ PRÁCTICAS DE TRABAJO
SEGURAS/ PRATICHE DI LAVORO SICURO/ VEILIG GEBRUIK/ SÄKER PRAXIS



Please read through the Safe Working Practice to ensure prevention of injury or damage to the greenhouse.

- Ensure you have read and fully understood the instruction manual and safety advice before assembling this product.
- At least two people are required to assemble this greenhouse.
- We recommend to use of safety gloves and a step ladder while assembling this greenhouse.
- Ensure that this greenhouse is handled and assembled according to these instructions.
- Do not attempt to assemble this greenhouse on a windy day.
- Ensure this greenhouse is assembled and erected on a flat surface.
- Ensure this product is assembled securely.
- Ensure this product is erected in a safe place.
- This product must be anchored to the ground.
- Do not use this product for anything other than its intended purposes.
- Ensure that all other materials used with this product are up to standard.



Veillez lire attentivement les pratiques de travail sécuritaires pour assurer la prévention des blessures ou des dommages à la serre.

- Assurez-vous d'avoir lu et bien compris le manuel d'instructions et les consignes de sécurité avant d'assembler ce produit.
- Au moins deux personnes seront nécessaires pour assembler cette serre.
- Nous vous recommandons d'utiliser des gants de sécurité et un escabeau lors de l'assemblage de cette serre.

SAFETY ADVICE

CONSEILS DE SÉCURITÉ/ SICHERHEITSHINWEIS/ CONSEJOS DE SEGURIDAD/ CONSIGLI PER LA SICUREZZA/ VEILIGHEIDSADVIIES/ SÄKERHETSÅD



- Assurez-vous que cette serre est manipulée et assemblée conformément aux instructions.
- N'essayez pas d'assembler cette serre par une journée venteuse.
- Assurez-vous que cette serre est assemblée et érigée sur une surface plane.
- Assurez-vous que ce produit est assemblé solidement.
- Assurez-vous que ce produit est érigé dans un endroit sûr.
- Ce produit doit être ancré au sol.
- N'utilisez pas ce produit à d'autres fins que celles pour lesquelles il a été conçu.
- Assurez-vous que tous les autres matériaux utilisés avec ce produit sont conformes aux normes.

La responsabilité de Monster Group UK Limited sera limitée à la valeur commerciale du produit.



Bitte lesen Sie sich die Hinweise zum sicheren Arbeitsverfahren durch, um Verletzungen oder Schäden am Gewächshaus zu vermeiden.

- Stellen Sie sicher, dass Sie die Bedienungsanleitung und die Sicherheitshinweise gelesen und vollständig verstanden haben, bevor Sie das Produkt zusammenbauen.
- Zum Aufbau des Gewächshauses sind mindestens zwei Personen erforderlich.
- Beim Aufbau des Gewächshauses empfehlen wir die Verwendung von Sicherheitshandschuhen und einer Trittleiter.
- Beachten Sie, dass das Gewächshaus gemäß dieser Anleitung gehandhabt und aufgebaut wird.
- Bauen Sie das Gewächshaus nicht an einem windigen Tag auf.
- Die Montage und Aufstellung des Gewächshauses sollte immer auf einer ebenen Fläche erfolgen.
- Überprüfen Sie, dass dieses Produkt stabil montiert ist.
- Stellen Sie sicher, dass dieses Produkt an einem sicheren Ort aufgebaut wird.
- Dieses Produkt muss im Boden verankert werden.

SAFETY ADVICE

CONSEILS DE SÉCURITÉ/ SICHERHEITSHINWEIS/ CONSEJOS DE SEGURIDAD/ CONSIGLI PER LA SICUREZZA/ VEILIGHEIDSADVIIES/ SÄKERHETSÅD



- Dieses Produkt sollte nicht für einen anderen als den vorgesehenen Zweck verwendet werden.
- Vergewissern Sie sich, dass alle anderen Materialien, die mit diesem Produkt verwendet werden, in gutem Zustand sind.

Die Haftung von Monster Group UK Limited ist auf den Handelswert des Produkts beschränkt.



Lea las Prácticas de trabajo seguras para garantizar la prevención de lesiones o daños al invernadero.

- Asegúrese de haber leído y entendido completamente el manual de instrucciones y los consejos de seguridad antes de ensamblar este producto.
- Se necesitan al menos dos personas para montar este invernadero.
- Recomendamos el uso de guantes de seguridad y una escalera de tijera durante el montaje de este invernadero.
- Asegúrese de manipular y ensamblar este invernadero de acuerdo con estas instrucciones.
- No intente armar este invernadero en un día ventoso.
- Asegúrese de que este invernadero esté ensamblado y erigido sobre una superficie plana.
- Asegúrese de que este producto esté ensamblado de forma segura.
- Asegúrese de montar este producto en un lugar seguro.
- Este producto debe estar anclado al suelo.
- No utilice este producto para ningún otro fin que no sea el previsto.
- Asegúrese de que todos los demás materiales utilizados con este producto cumplan con los estándares.

La responsabilidad de Monster Group UK Limited estará limitada únicamente al valor comercial del producto.

SAFETY ADVICE

CONSEILS DE SÉCURITÉ/ SICHERHEITSHINWEIS/ CONSEJOS DE SEGURIDAD/
CONSIGLI PER LA SICUREZZA/ VEILIGHEIDSADVIIES/ SÄKERHETSÅD



Si prega di leggere le avvertenze di sicurezza per prevenire di lesioni o danni al dispositivo.

- Assicurarsi di aver letto e compreso completamente il manuale di istruzioni e i consigli di sicurezza prima di assemblare questo prodotto.
- Per assemblare questa serra sono necessarie almeno due persone.
- Si consiglia di utilizzare guanti di sicurezza e una scala a pioli durante il montaggio di questa serra.
- Assicurarsi che questa serra venga maneggiata e assemblata secondo queste istruzioni.
- Non tentare di assemblare questa serra in una giornata ventosa.
- Assicurati che questa serra sia assemblata ed eretta su una superficie piana.
- Assicurati che questo prodotto sia assemblato in modo sicuro.
- Assicurarsi che questo prodotto sia eretto in un luogo sicuro.
- Questo prodotto deve essere ancorato al suolo.
- Non utilizzare questo prodotto per scopi diversi da quelli previsti.
- Assicurarsi che tutti gli altri materiali utilizzati con questo prodotto siano conformi agli standard.

La responsabilità di Monster Group UK Limited sarà limitata al solo valore commerciale del prodotto.



Lees de Veilige Werkpraktijk door om letsel of schade aan de kas te voorkomen.

- Zorg ervoor dat u de handleiding en het veiligheidsadvies hebt gelezen en volledig hebt begrepen voordat u dit product in elkaar zet.
- Er zijn minstens twee mensen nodig om deze kas in elkaar te zetten.
- We raden aan om veiligheidshandschoenen en een trapladder te gebruiken tijdens het monteren van deze kas.
- Zorg ervoor dat deze kas wordt behandeld en geassembleerd volgens deze instructies.
- Probeer deze kas niet op een winderige dag in elkaar te zetten.

SAFETY ADVICE

CONSEILS DE SÉCURITÉ/ SICHERHEITSHINWEIS/ CONSEJOS DE SEGURIDAD/
CONSIGLI PER LA SICUREZZA/ VEILIGHEIDSADVIIES/ SÄKERHETSÅRÅD



- Zorg ervoor dat deze kas op een vlakke ondergrond wordt geassembleerd en gebouwd.
- Zorg ervoor dat dit product veilig is gemonteerd.
- Zorg ervoor dat dit product op een veilige plaats wordt geplaatst.
- Dit product moet aan de grond worden verankerd.
- Gebruik dit product niet voor iets anders dan de beoogde doeleinden.
- Zorg ervoor dat alle andere materialen die met dit product worden gebruikt, aan de norm voldoen.

De aansprakelijkheid van Monster Group UK Limited is beperkt tot de commerciële waarde van het product.



Läs igenom Säker Arbetspraxis för att säkerställa förebyggande av skador på kropp eller skador på växthuset.

- Se till att du har läst och till fullo förstått bruksanvisningen och säkerhetsråden innan du monterar denna produkt.
- Det krävs minst två personer för att montera detta växthus.
- Vi rekommenderar att du använder skyddshandskar och en stege när du monterar detta växthus.
- Se till att detta växthus hanteras och monteras enligt dessa instruktioner.
- Försök inte att montera detta växthus på en blåsig dag.
- Se till att detta växthus är monterat och uppfört på en plan yta.
- Se till att denna produkt är säkert monterad.
- Se till att denna produkt placeras på en säker plats.
- Denna produkt måste förankras i marken.
- Använd inte denna produkt för något annat än dess avsedda ändamål.
- Se till att alla andra material som används med denna produkt uppfyller standarden.

Monster Group UK Limiteds ansvar begränsas endast till produktens kommersiella värde.

USER GUIDE

MODE D'EMPLOI/ BENUTZERLEITFADEN/ GUÍA DEL USUARIO/ GUIDA
UTENTE / HANDLEIDING/ BRUKSANVISNING

ASSEMBLY INSTRUCTIONS

INSTRUCTIONS DE MONTAGE/ MONTAGEANLEITUNGEN/ INSTRUCCIONES DE
MONTAJE / ISTRUZIONI PER IL MONTAGGIO/ MONTAGE-INSTRUCTIES/ MONTERINGS
INSTRUKTIONER

An Allen Key and a spanner are included / Une clé Allen et une clé sont incluses /
Ein Inbusschlüssel und ein Schraubenschlüssel sind im Lieferumfang enthalten / Se incluye
una llave Allen y una llave inglesa / Sono inclusi una chiave a brugola e una chiave inglese /
Een inbusleutel en een steeksleutel zijn inbegrepen / En insexnyckel och en skiftnyckel ingår

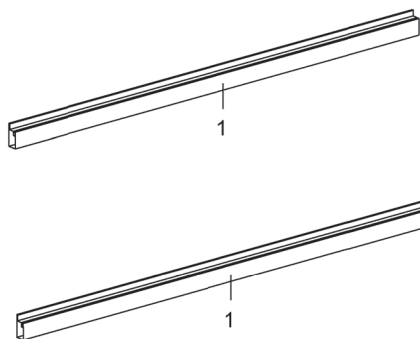



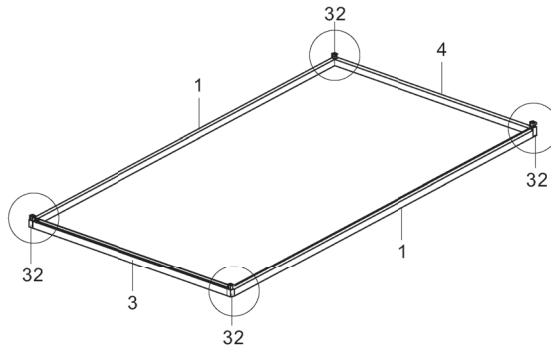

Picture	NO.	Qty.
	1	2

ASSEMBLY INSTRUCTIONS

INSTRUCTIONS DE MONTAGE/ MONTAGEANLEITUNGEN/ INSTRUCCIONES DE MONTAJE / ISTRUZIONI PER IL MONTAGGIO/ MONTAGE-INSTRUCTIES/ MONTERINGS INSTRUKTIONER



Picture	NO.	Qty.
	3	1
	4	1
	32	4
	42	8

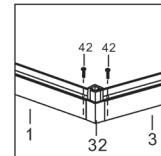
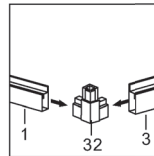

ASSEMBLY INSTRUCTIONS

INSTRUCTIONS DE MONTAGE/ MONTAGEANLEITUNGEN/ INSTRUCCIONES DE MONTAJE / ISTRUZIONI PER IL MONTAGGIO/ MONTAGE-INSTRUCTIES/ MONTERINGS INSTRUKTIONER

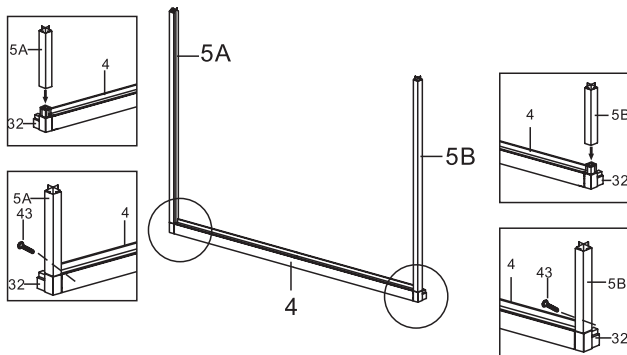
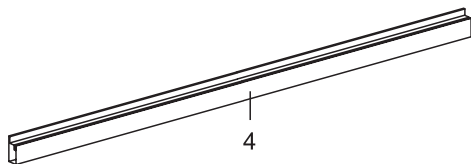

Picture	NO.	Qty.
	5A	1
	5B	1
	43	2

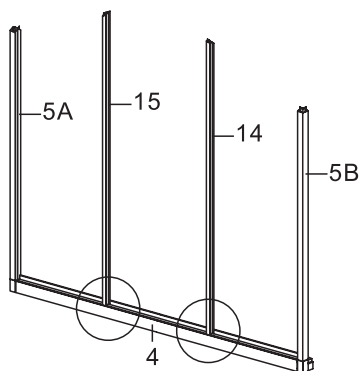

Picture	NO.	Qty.
	14	1
	15	1
	42	2

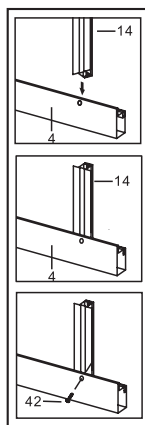

ASSEMBLY INSTRUCTIONS

INSTRUCTIONS DE MONTAGE/ MONTAGEANLEITUNGEN/ INSTRUCCIONES DE MONTAJE / ISTRUZIONI PER IL MONTAGGIO/ MONTAGE-INSTRUCTIES/ MONTERINGS INSTRUKTIONER

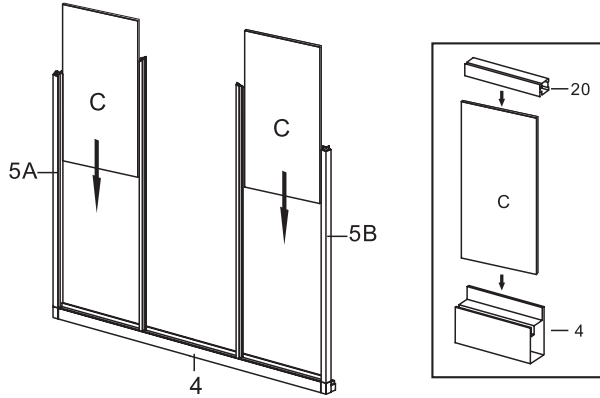

Picture	NO.	Qty.
	C	2
	20	2

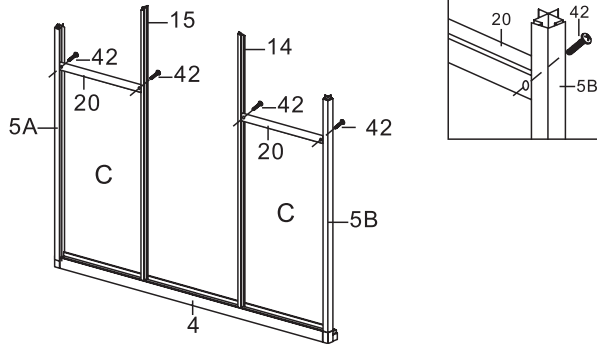

Picture	NO.	Qty.
	42	4

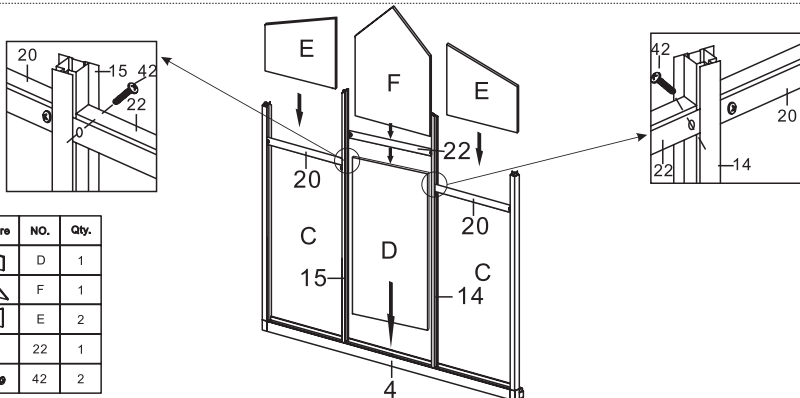

Picture	NO.	Qty.
	D	1
	F	1
	E	2
	22	1
	42	2

ASSEMBLY INSTRUCTIONS

INSTRUCTIONS DE MONTAGE/ MONTAGEANLEITUNGEN/ INSTRUCCIONES DE MONTAJE / ISTRUZIONI PER IL MONTAGGIO/ MONTAGE-INSTRUCTIES/ MONTERINGS INSTRUKTIONER

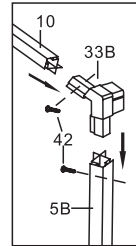
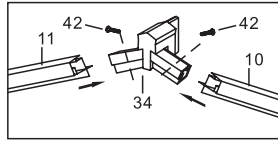
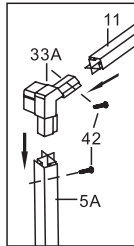

Picture	NO.	Qty.
	10	1
	11	1
	34	1
	33A	1
	33B	1
	42	6

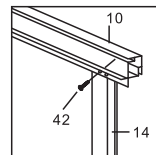
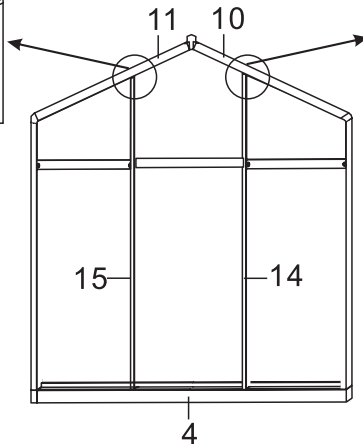
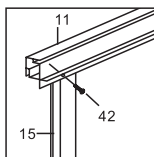
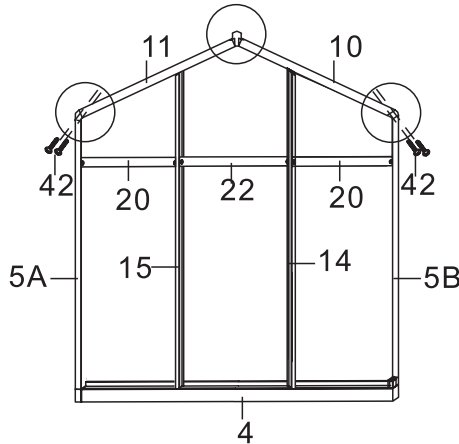

Picture	NO.	Qty.
	42	2

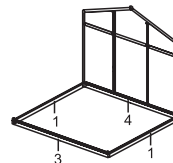

ASSEMBLY INSTRUCTIONS

INSTRUCTIONS DE MONTAGE/ MONTAGEANLEITUNGEN/ INSTRUCCIONES DE MONTAJE / ISTRUZIONI PER IL MONTAGGIO/ MONTAGE-INSTRUCTIES/ MONTERINGS INSTRUKTIONER

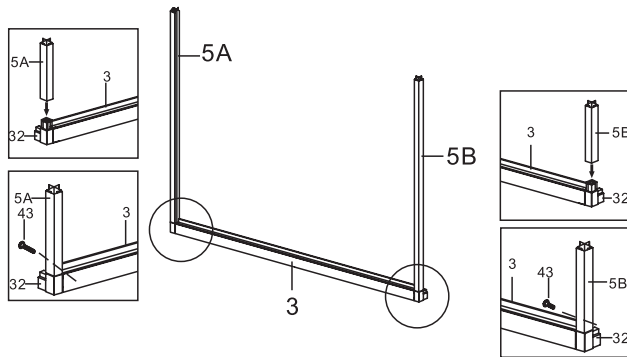
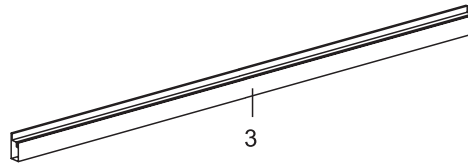

Picture	NO.	Qty.
	5A	1
	5B	1
	43	2

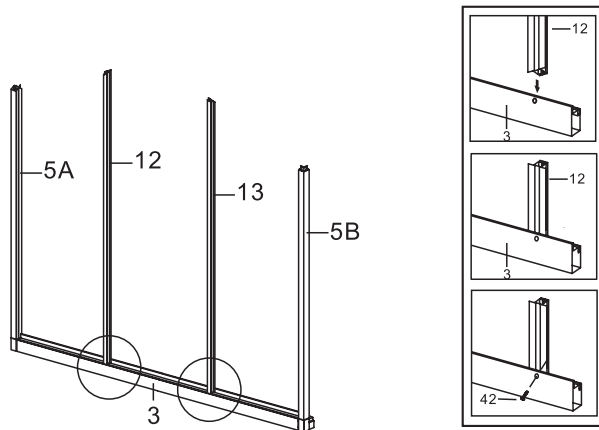

Picture	NO.	Qty.
	12	1
	13	1
	42	2

ASSEMBLY INSTRUCTIONS

INSTRUCTIONS DE MONTAGE/ MONTAGEANLEITUNGEN/ INSTRUCCIONES DE MONTAJE / ISTRUZIONI PER IL MONTAGGIO/ MONTAGE-INSTRUCTIES/ MONTERINGS INSTRUKTIONER

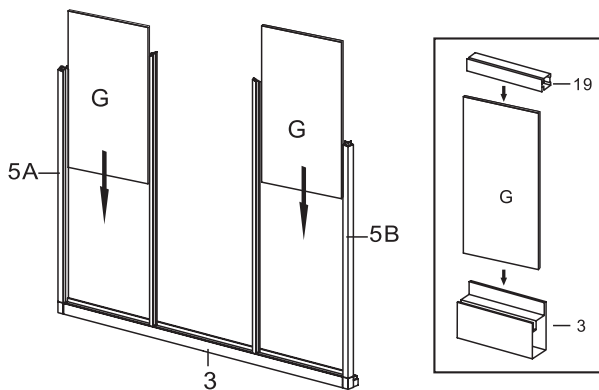

Picture	NO.	Qty.
	G	2
	19	2

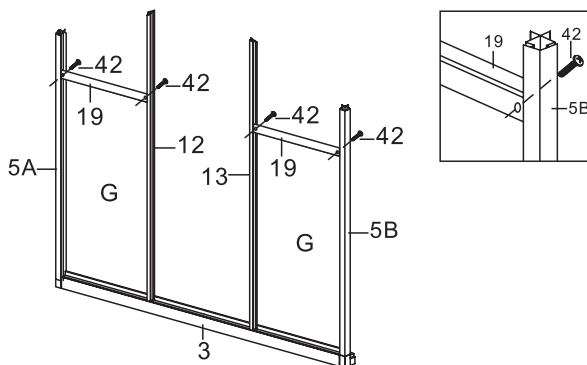

Picture	NO.	Qty.
	42	4

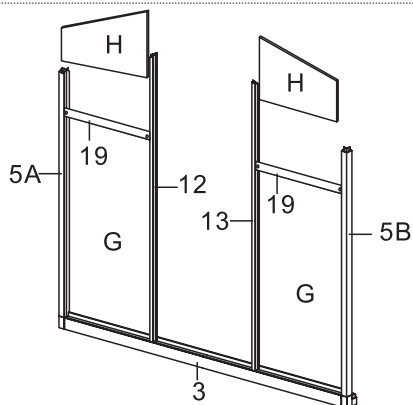

Picture	NO.	Qty.
	H	2

ASSEMBLY INSTRUCTIONS

INSTRUCTIONS DE MONTAGE/ MONTAGEANLEITUNGEN/ INSTRUCCIONES DE MONTAJE / ISTRUZIONI PER IL MONTAGGIO/ MONTAGE-INSTRUCTIES/ MONTERINGS INSTRUKTIONER

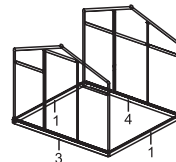
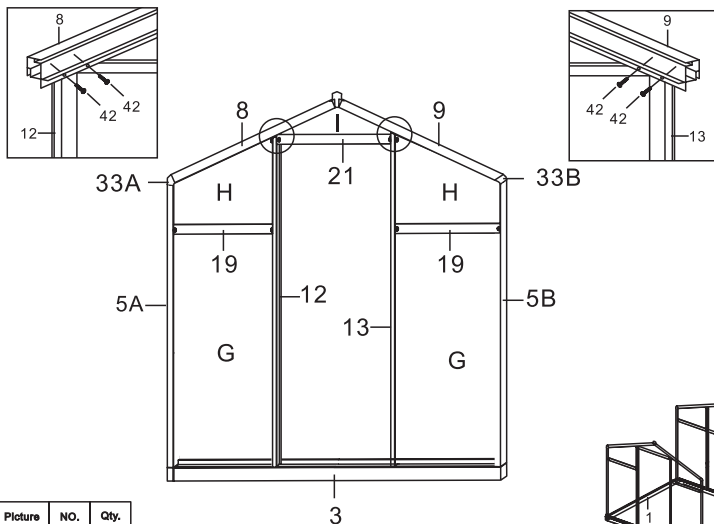
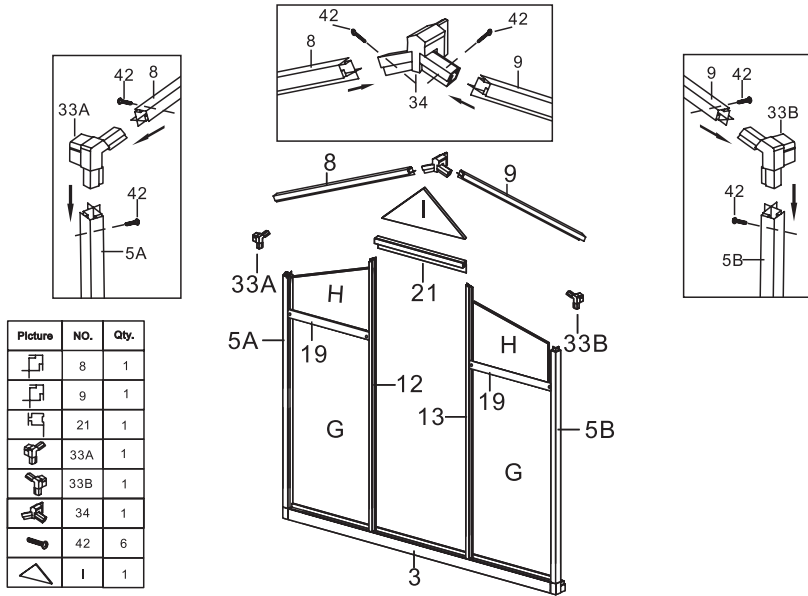

ASSEMBLY INSTRUCTIONS

INSTRUCTIONS DE MONTAGE/ MONTAGEANLEITUNGEN/ INSTRUCCIONES DE MONTAJE / ISTRUZIONI PER IL MONTAGGIO/ MONTAGE-INSTRUCTIES/ MONTERINGS INSTRUKTIONER

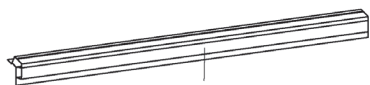

6



6

Picture	NO.	Qty.
	6	2

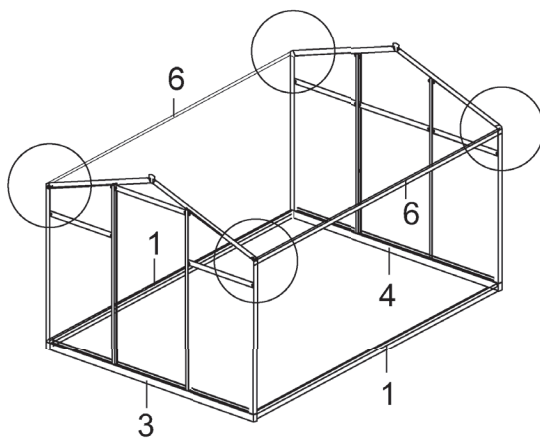
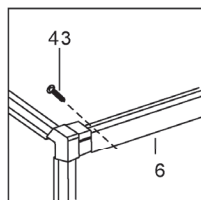
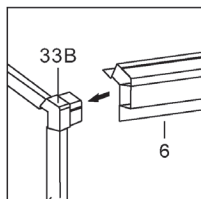

Picture	NO.	Qty.
	43	4

ASSEMBLY INSTRUCTIONS

INSTRUCTIONS DE MONTAGE/ MONTAGEANLEITUNGEN/ INSTRUCCIONES DE MONTAJE / ISTRUZIONI PER IL MONTAGGIO/ MONTAGE-INSTRUCTIES/ MONTERINGS INSTRUKTIONER

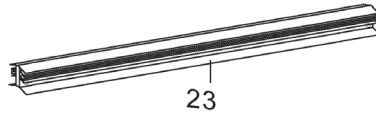

Picture	NO.	Qty.
	23	1

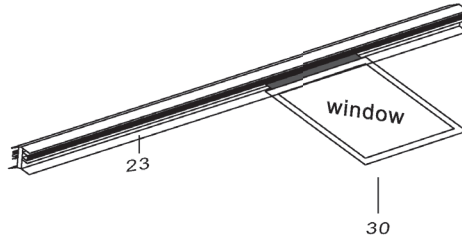
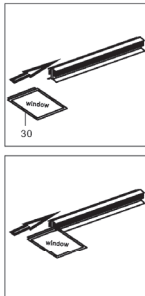

Picture	NO.	Qty.
	30	1

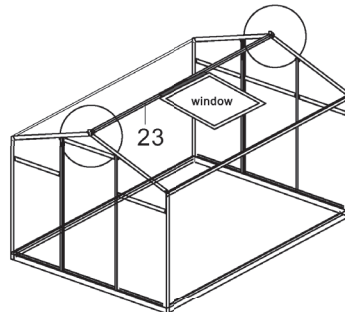
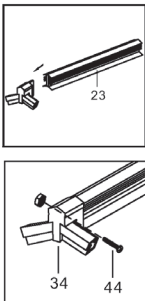

Picture	NO.	Qty.
	44	2

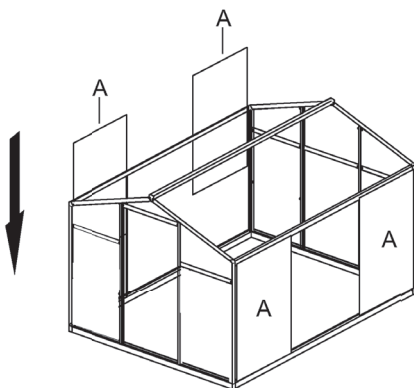

ASSEMBLY INSTRUCTIONS

INSTRUCTIONS DE MONTAGE/ MONTAGEANLEITUNGEN/ INSTRUCCIONES DE MONTAJE / ISTRUZIONI PER IL MONTAGGIO/ MONTAGE-INSTRUCTIES/ MONTERINGS INSTRUKTIONER

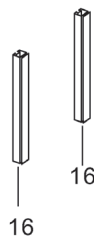
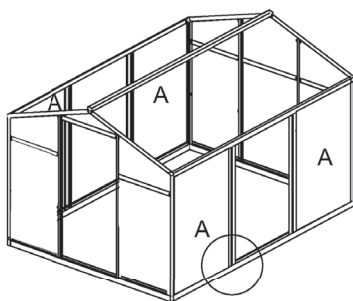
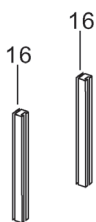

Picture	NO.	Qty.
	A	4



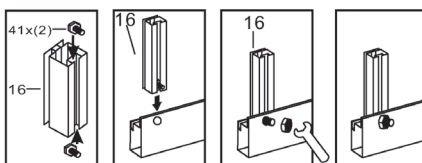

Picture	NO.	Qty.
	16	4
	41	8



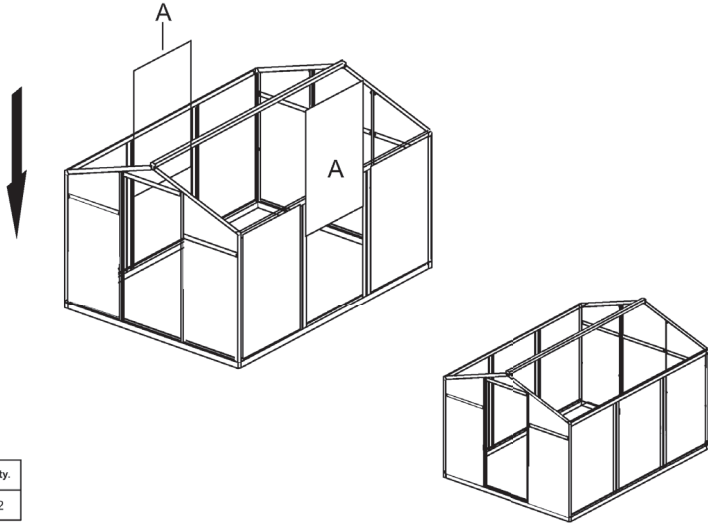

ASSEMBLY INSTRUCTIONS

INSTRUCTIONS DE MONTAGE/ MONTAGEANLEITUNGEN/ INSTRUCCIONES DE MONTAJE / ISTRUZIONI PER IL MONTAGGIO/ MONTAGE-INSTRUCTIES/ MONTERINGS INSTRUKTIONER

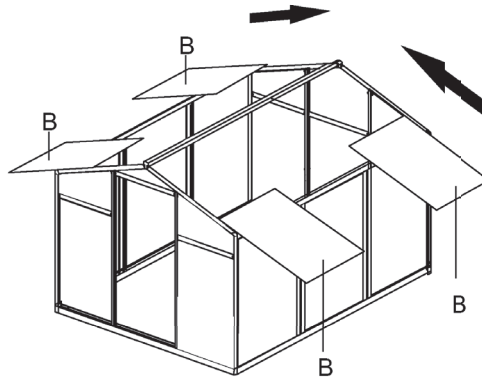

Picture	NO.	Qty.
	A	2



Picture	NO.	Qty.
	B	4

ASSEMBLY INSTRUCTIONS

INSTRUCTIONS DE MONTAGE/ MONTAGEANLEITUNGEN/ INSTRUCCIONES DE MONTAJE / ISTRUZIONI PER IL MONTAGGIO/ MONTAGE-INSTRUCTIES/ MONTERINGS INSTRUKTIONER

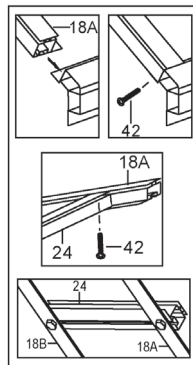
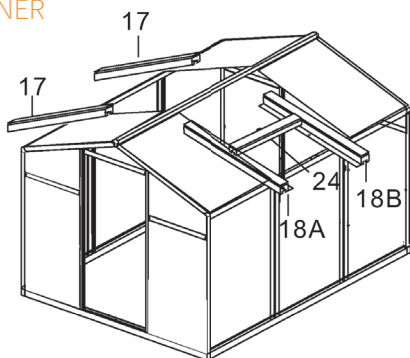

Picture	NO.	Qty.
	17	2
	18A	1
	18B	1
	24	1
	41	4
	42	6

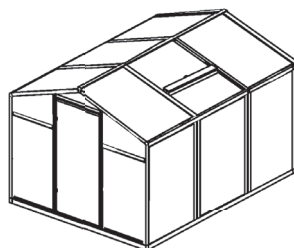
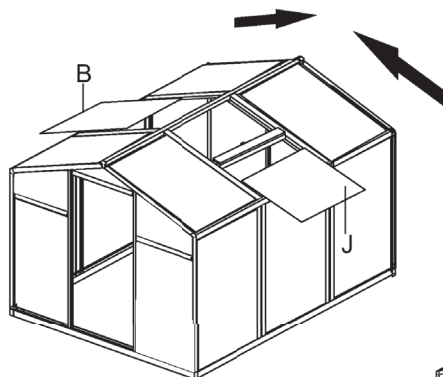
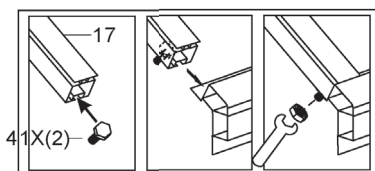

Picture	NO.	Qty.
	B	1
	J	1

ASSEMBLY INSTRUCTIONS

INSTRUCTIONS DE MONTAGE/ MONTAGEANLEITUNGEN/ INSTRUCCIONES DE MONTAJE / ISTRUZIONI PER IL MONTAGGIO/ MONTAGE-INSTRUCTIES/ MONTERINGS INSTRUKTIONER

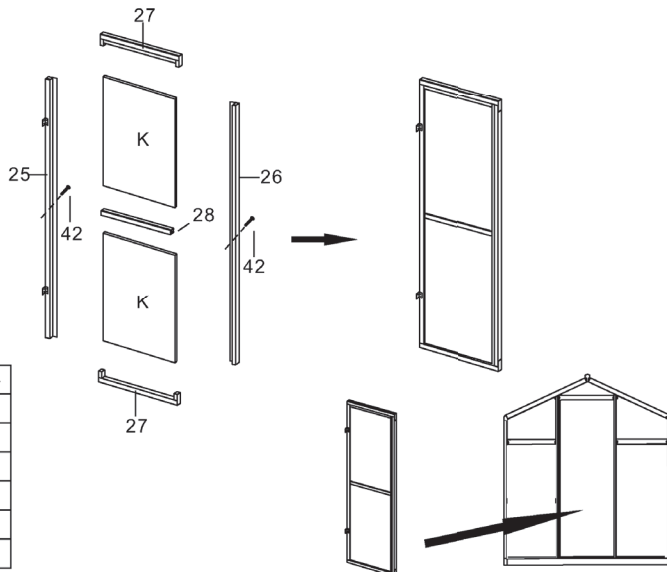
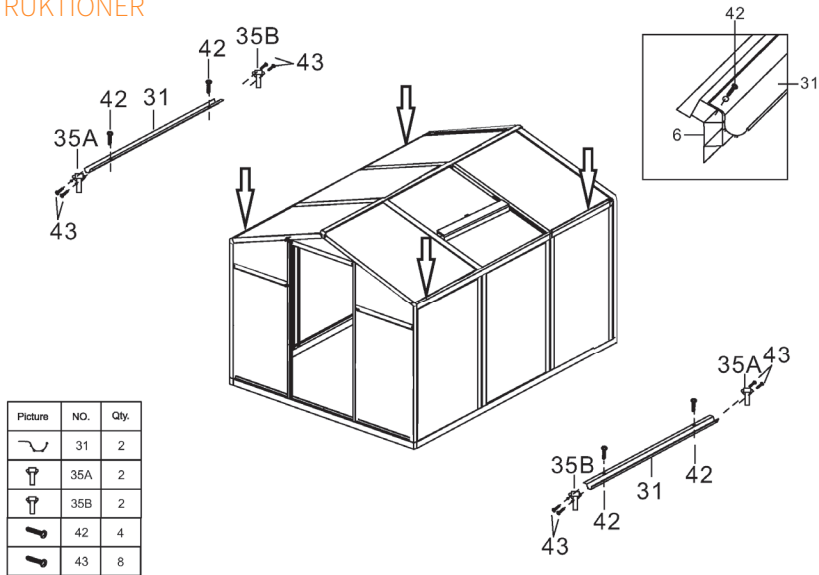

ASSEMBLY INSTRUCTIONS

INSTRUCTIONS DE MONTAGE/ MONTAGEANLEITUNGEN/ INSTRUCCIONES DE MONTAJE / ISTRUZIONI PER IL MONTAGGIO/ MONTAGE-INSTRUCTIES/ MONTERINGS INSTRUKTIONER

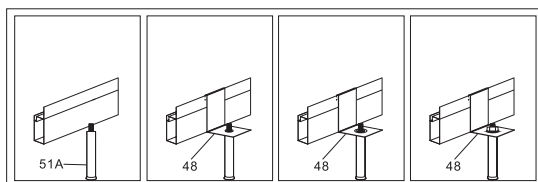
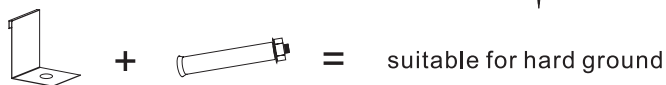
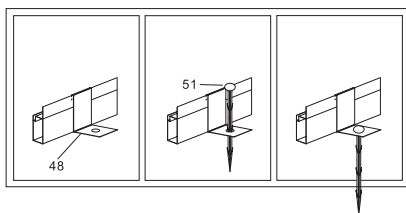
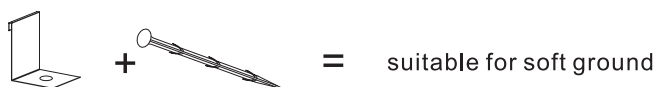
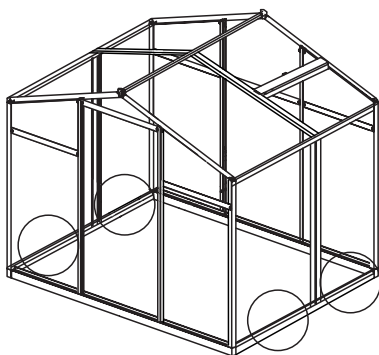

TROUBLESHOOTING

DÉPANNAGE / FEHLERBEHEBUNG / SOLUCIÓN DE PROBLEMAS /
RISOLUZIONE DEI PROBLEMI / PROBLEEM OPLOSSEN / FELSÖKNING



WHAT DO I DO IF THERE ARE MISSING PARTS FROM MY ORDER?

If there appears to be any part missing from your order, contact our friendly and helpful Customer Support Team within 7 days of receipt.



QUE FAIRE S'IL MANQUE DES PIÈCES À MA COMMANDE?

S'il semble manquer des pièces à votre commande, contactez notre équipe du service client dans les 7 jours suivant la réception.



WAS MACHE ICH, WENN BEI MEINER BESTELLUNG TEILE FEHLEN?

Falls bei Ihrer Bestellung ein Teil zu fehlen scheint, wenden Sie sich bitte innerhalb von 7 Tagen nach Erhalt der Ware an unser freundliches und hilfsbereites Kundenservice-Team.



¿QUÉ PUEDO HACER SI LE FALTAN PIEZAS A MI PEDIDO?

Si parece faltar alguna pieza en su pedido, por favor, comuníquese con nuestro amable y servicial Equipo de Atención al Cliente en los 7 días posteriores a la recepción de su pedido.



COSA DEVO FARE SE NEL MIO ORDINE CI SONO DELLE PARTI MANCANTI?

Se sembra che all'interno del tuo ordine manchino delle parti, contatta il nostro gentile e disponibile team di assistenza clienti entro 7 giorni dalla ricezione del tuo ordine.

TROUBLESHOOTING

DÉPANNAGE / FEHLERBEHEBUNG / SOLUCIÓN DE PROBLEMAS /
RISOLUZIONE DEI PROBLEMI / PROBLEEM OPLOSSEN / FELSÖKNING



WAT MOET IK DOEN ALS ER ONDERDELEN VAN MIJN BESTELLING ONTBREKEN?

Neem wanneer een onderdeel van je bestelling ontbreekt binnen 7 dagen na ontvangst contact op met onze vriendelijke en behulpzame klantenservice.



VAD GÖR JAG OM DET SAKNAS DELAR FRÅN MIN BESTÄLLNING?

Om det verkar som om någon del saknas i din beställning, kontakta vårt vänliga och hjälpsamma kundsupportteam inom 7 dagar efter mottagandet.

FOR ALL OTHER ISSUES, PLEASE CONTACT OUR
CUSTOMER SUPPORT TEAM.

BLANK PAGE

Monster Group (UK) is one of the UK's fastest growing online retailers. We supply a diverse range of products which offer exceptional value for money. We strive to provide the best possible customer experience with free UK delivery across all our products and a Monster Guarantee for 100% satisfaction.

For information regarding this device or other products from our Monster divisions please contact Sales.

SALES

TEL: 01347 878 888

EMAIL: hello@monstershop.co.uk

For queries about this device, warranty, returns or reporting faults please contact Support.

SUPPORT

TEL: 01347 878 887

EMAIL: help@monstershop.co.uk

Pour plus d'informations concernant cet appareil ou d'autres produits de nos divisions de Monster veuillez utiliser les détails suivants ci-dessous.

DÉPARTEMENT COMMERCIAL

TEL: 01347 878 888

EMAIL: bonjour@monstershop.eu

Pour les interrogations concernant cet appareil, la garantie, les retours ou les défauts de déclaration veuillez utiliser les détails suivants ci-dessous.

DÉPARTEMENT DE SOUTIEN

TEL: 01347 878 887

EMAIL: help@monstershop.co.uk

Para información sobre este dispositivo u otros productos de nuestras divisiones de Monster por favor use los siguientes detalles.

DEPARTAMENTO DE VENTAS

TEL: 01347 878 888

EMAIL: hola@monstershop.eu

Para consultas sobre este dispositivo, la garantía, devoluciones o denuncias de fallos por favor use los siguientes detalles.

DEPARTAMENTO DE SOPORTE

TEL: 01347 878 887

EMAIL: help@monstershop.co.uk

Für Informationen bezüglich dieses Geräts oder anderer Produkte aus unserer Monster-Abteilung, benutzen sie die folgenden unten aufgeführten Angaben.

VERKAUFABTEILUNG

TEL: 01347 878 888

EMAIL: hallo@monstershop.eu

Für Fragen über dieses Gerät, die Garantie, Rückgaben oder bei Störungen, benutzen sie die folgenden unten aufgeführten Angaben.

SUPPORT-ABTEILUNG

TEL: 01347 878 887

EMAIL: help@monstershop.co.uk

Per informazioni riguardanti questo dispositivo o altri prodotti dalle categorie Monster utilizzare i dettagli sotto riportati.

DIPARTIMENTO VENDITE

TEL: 01347 878 888

EMAIL: ciao@monstershop.eu

Per domande riguardo dispositivo, garanzia, reso o per riferire di guasti, utilizzare i dettagli sotto riportati.

DIPARTIMENTO SUPPORTO

TEL: 01347 878 887

EMAIL: help@monstershop.co.uk

Monster House, Alan Farnaby Way,
Sheriff Hutton Industrial Estate,
Sheriff Hutton, York, YO60 6PG
www.monstershop.co.uk



 Try **Monster**. Buy **Monster**. Be **Monster**. 