

# KuK

SKU	210776
CLIMATE CLASS	N-ST
ELECTRIC PROTECT CLASS	I
CAPACITY	175L
RATED VOLTAGE	22V-240V~
RATED FREQUENCY	50Hz
RATED CURRENT	1.0A
POWER INPUT	160W
ENERGY CONSUMPTION	1.15kW·h/24h
REFRIGERANT	R600a
CHARGING AMOUNT	50g
FOAM BLOWING AGENT	Cyclopentane
LIGHT	6W

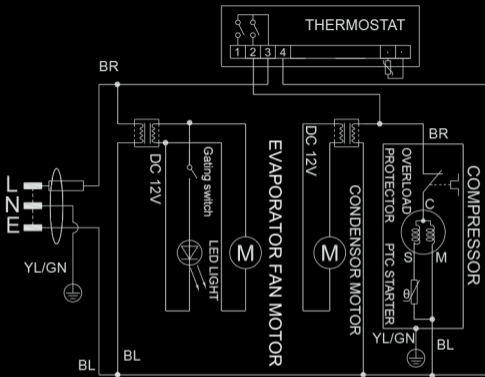

UK  
CA



CE



**CAUTION: HOT SURFACE**  
Touching the compressor could  
result in burns.

