

Camper Overhead Cabinet

211119 - 211137

INSTRUCTION MANUAL

www.monstershop.co.uk



SPECIFICATION

PRODUCT DESCRIPTION

Our Monster Camper Overhead Cabinets are designed to provide the perfect storage solution. We offer a wide range of sizes to ensure a perfect fit for your camper van. These cabinets are ideal for any self build project and are a great way to add additional storage in your camper van.

PRODUCT SPECIFICS

211119 / 211136

DIMENSIONS: 1200 x 350 x 350mm

MATERIAL: Birchwood Ply

211120

DIMENSIONS: 1000 x 350 x 350mm

MATERIAL: Birchwood Ply

211121

DIMENSIONS: 800 x 350 x 350mm

MATERIAL: Birchwood Ply

211122

DIMENSIONS: 1200 x 300 x 300mm

MATERIAL: Birchwood Ply

211129

DIMENSIONS: 1000 x 300 x 300mm

MATERIAL: Birchwood Ply

211130

DIMENSIONS: 800 x 300 x 300mm

MATERIAL: Birchwood Ply

211133/211137

DIMENSIONS: 1200 x 250 x 250mm

MATERIAL: Birchwood Ply

211134

DIMENSIONS: 1000 x 250 x 250mm

MATERIAL: Birchwood Ply

211135

DIMENSIONS: 800 x 250 x 250mm







MATERIAL: Birchwood Ply

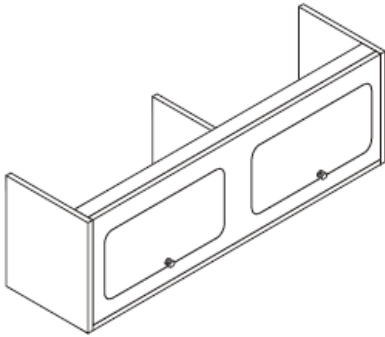

Three in-one connection pieces, which contain three parts- excentre fittings(B),steel connectors(A) and plastic pre-buried nuts(pre-fitted), you should first assemble all steel connectors to fit into plastic pre-buried nuts before first-step assembly.

SPECIFICATION

ITEM CONTENTS

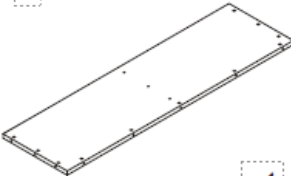
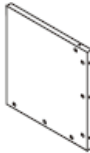
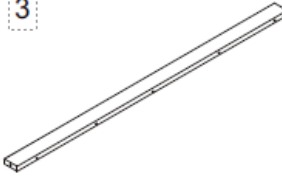
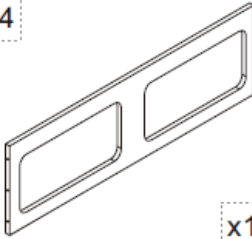
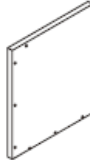
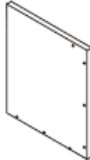

<p>A</p>  <p>x31</p>	<p>B</p>  <p>x31</p>
<p>C</p>  <p>x28</p>	<p>D</p>  <p>x4</p>
<p>E</p>  <p>x2</p>	<p>F</p>  <p>x4</p>

<p>1</p>  <p>x1</p>	<p>2</p>  <p>x1</p>	<p>3</p>  <p>x1</p>
<p>4</p>  <p>x1</p>	<p>5</p>  <p>x1</p>	<p>6</p>  <p>x1</p>
<p>7</p>  <p>x1</p>	<p>8</p>  <p>x1</p>	

SAFETY ADVICE

SAFE WORKING PRACTICE

Please read through the Safe Working Practice to ensure prevention of injury or damage to the device.

- To ensure the cabinet is build correctly we advise following our instructions, brackets must be installed using pre-drill holes.
- Do not use this product for anything other than its intended purposes.
- Ensure you have read and fully understood the instruction manual and safety advice before using this product.
- Do not throw away the packaging until all included parts are located and confirmed.
- Inspect the product for signs of damage before installation, and do not attempt to install the product if it is damaged.
- There may be debris and/or sawdust in the pre-drilled holes. Remove this before commencing with assembly. Use gloves to remove it.
- Ensure the the camper cabinet is only used indoors.
- Ensure a clean workspace.
- There may be debris and/or sawdust in the pre-drilled holes. Remove this before commencing with assembly. Use gloves to remove it.
- We strongly recommend the use of respiratory PPE (rated P2 as a minimum) when cutting, sanding or drilling this product to prevent inhalation of harmful dust.
- Ensure any modifications are made in open air, a safe distance away from others.

USER GUIDE

ASSEMBLY INSTRUCTIONS

1. Fit front panel (part 3) and bottom panel (part 1) onto middle panel (part 2) by screwing Excentre fittings(B) into plastic pre-buried nuts.
2. Screwing the hinges(D) into pre-buried nuts by using screws(C), if needed adjust left-right or up-down position by tightening or loosen the screws on hinges to ensure the doors(part 7 and part 8) can be positioned rightly.
3. Fit front panel(part 4) on the top and bottom panel assembly.
4. Fit right side panel (part 6) on the front and bottom assembly.

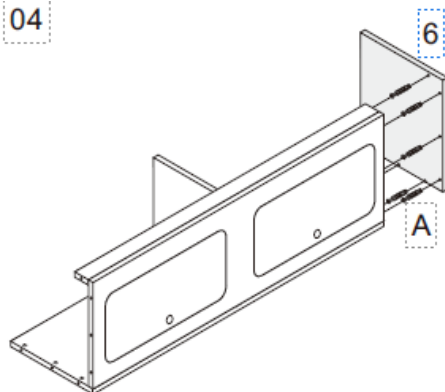
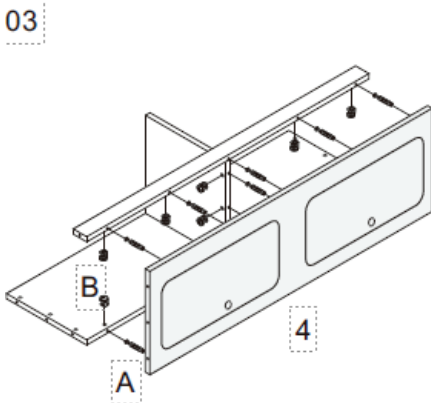
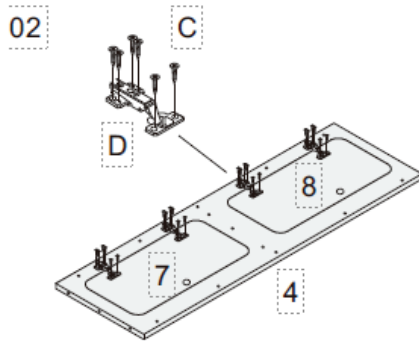
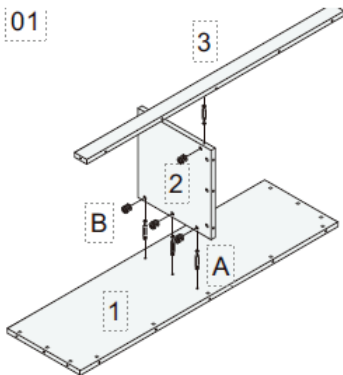

USER GUIDE

ASSEMBLY INSTRUCTIONS

05

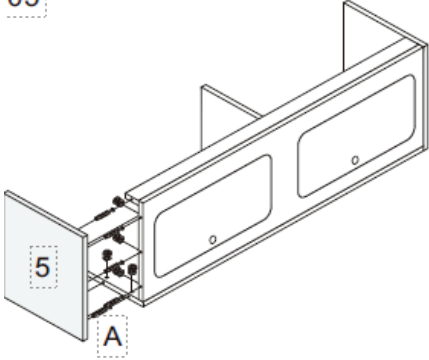

5. Continuing to fit left side panel(Part 5).

6. Select door lockers (E) you will need to detach the doors from the hinges and lay your doors flat. Using a rubber hammer gently fit latch rosette. Place latch into position and fit into place. Screw door blocks (F) into pre-buried nuts.

06

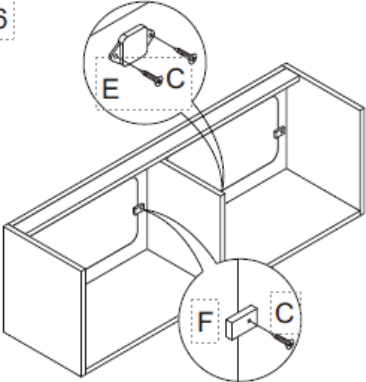

TROUBLESHOOTING

RESOLUTION GUIDE

WHAT DO I DO IF THERE ARE MISSING PARTS FROM MY ORDER?

If there appears to be any part missing from your order, contact our friendly and helpful Customer Support Team within 7 days of receipt.

WHAT DO I DO IF SCREWS WILL NOT FIT INTO THE HOLES?

There may be some sawdust/debris in the holes. This will need to be removed before building recommences. Use gloves to remove any debris, just in case wood splinters are present.

**FOR ALL OTHER ISSUES, PLEASE CONTACT OUR
CUSTOMER SUPPORT TEAM.**

SPÉCIFICATIONS

DESCRIPTION DU PRODUIT

Notre meuble de rangement en hauteur Monster pour camping-car a été conçu pour fournir une solution de rangement idéale pour votre véhicule. Ce meuble est disponible en plusieurs tailles pour convenir à tout type de camping-car. Ces armoires sont idéales pour tout projet à faire soi-même et seront parfaites pour ajouter du stockage supplémentaire dans votre camping-car.

CARACTÉRISTIQUES DU PRODUIT

211119 / 211136

DIMENSIONS : 1200 x 350 x 350mm

MATIÈRE: Bois de bouleau

211120

DIMENSIONS : 1000 x 350 x 350mm

MATIÈRE: Bois de bouleau

211121

DIMENSIONS : 800 x 350 x 350mm

MATIÈRE: Bois de bouleau

211122

DIMENSIONS : 1200 x 300 x 300mm

MATIÈRE: Bois de bouleau

211129

DIMENSIONS : 1000 x 300 x 300mm

MATIÈRE: Bois de bouleau

211130

DIMENSIONS : 800 x 300 x 300mm

MATIÈRE: Bois de bouleau

211133/211137

DIMENSIONS : 1200 x 250 x 250mm

MATIÈRE: Bois de bouleau

211134

DIMENSIONS : 1000 x 250 x 250mm

MATIÈRE: Bois de bouleau

211135

DIMENSIONS : 800 x 250 x 250mm







MATIÈRE: Bois de bouleau

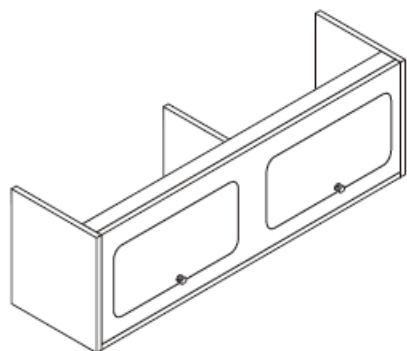



Trois pièces de connexion en une, contenant trois parties : les raccords excentriques (B), les connecteurs en acier (A) et les écrous en plastique pré-encastés (prémontés). Vous devez d'abord assembler tous les connecteurs en acier pour qu'ils s'insèrent dans les écrous en plastique pré-encastés avant la première étape de l'assemblage

SPÉCIFICATIONS

CONTENU

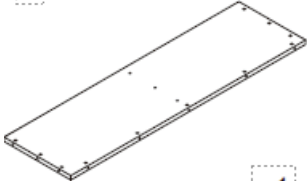
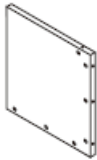

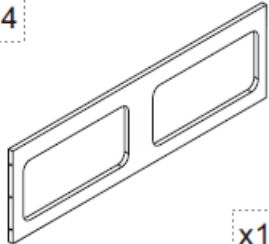
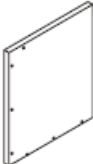
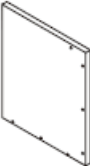
A  x31	B  x31
C  x28	D  x4
E  x2	F  x4

1  x1	2  x1	3  x1
4  x1	5  x1	6  x1
7  x1	8  x1	

CONSEILS DE SÉCURITÉ

PRATIQUE DE TRAVAIL SÉCURITAIRE

Veillez lire les consignes de sécurité afin d'éviter toute blessure ou tout dommage sur le produit.

- Afin de vous assurer que le meuble est assemblé correctement, nous vous conseillons de suivre nos instructions. Les supports doivent être installés en utilisant les trous pré-perçés.
- N'utilisez pas ce produit à d'autres fins que celles pour lesquelles il a été conçu.
- Assurez-vous d'avoir bien lu et compris le manuel d'utilisations et les conseils de sécurité avant d'utiliser ce produit.
- Ne jetez pas l'emballage tant que toutes les pièces incluses n'ont pas été localisées et comptées.
- Avant l'installation, vérifiez que le produit n'est pas endommagé si c'est le cas, ne tentez pas de l'installer.
- Des débris et/ou de la sciure de bois peuvent se trouver dans les trous pré-perçés. Retirez-les avant de commencer l'assemblage. Veillez utiliser des gants pour les retirer.
- Veillez à ce que ce meuble camping-car soit utilisé uniquement à l'intérieur.
- Veillez à ce que l'espace de travail soit propre.
- Nous recommandons vivement l'utilisation d'un EPI respiratoire (classe P2 au minimum) lors de la découpe, du ponçage ou du perçage de ce produit afin d'éviter l'inhalation de poussières nocives.
- Veillez à ce que toutes les modifications soient effectuées à l'air libre, à une distance sûre des autres personnes:

MODE D'EMPLOI

INSTRUCTIONS D'ASSEMBLAGE

1. Montez le panneau avant (partie 3) et le panneau inférieur (partie 1) sur le panneau central (partie 2) en vissant les raccords excentrés (B) dans les écrous en plastique pré-perçés.
2. Visser les charnières (D) dans les écrous pré-encastés à l'aide des vis (C). Si nécessaire, ajuster la position gauche-droite ou haut-bas en serrant ou desserrant les vis des charnières pour vous assurer que les portes (partie 7 et partie 8) puissent être positionnées correctement.
3. Installez le panneau frontal (partie 4) sur l'ensemble des panneaux supérieur et inférieur.
4. Installez le panneau latéral droit (partie 6) sur l'assemblage du panneau avant et du panneau inférieur.

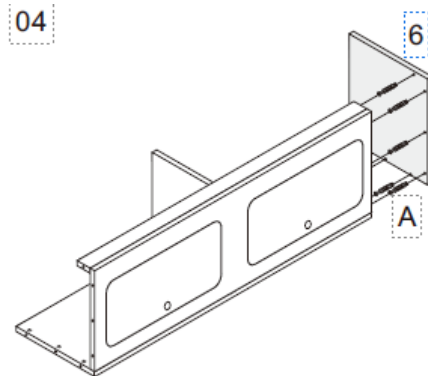
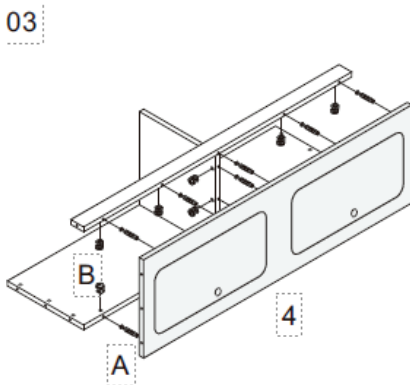
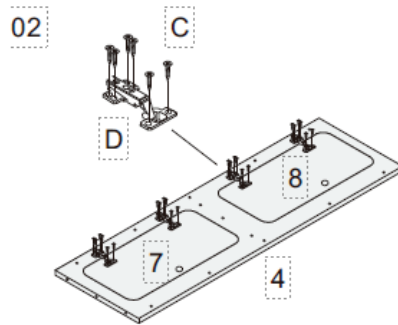
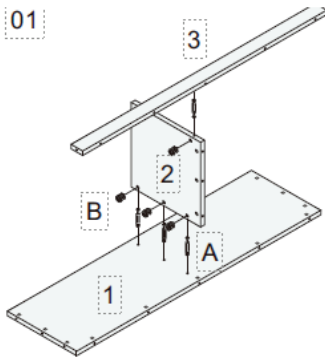

MODE D'EMPLOI

INSTRUCTIONS D'ASSEMBLAGE

05

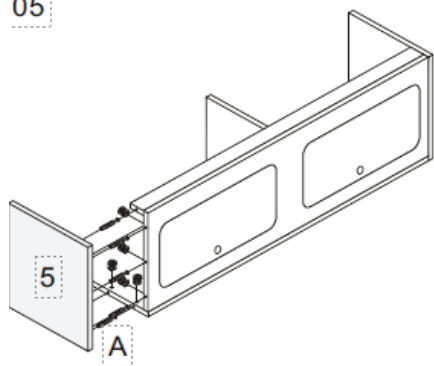

5. Continuez à monter le panneau latéral gauche (partie 5).

6. Pour les casiers à portes (E), vous devrez détacher les portes de leurs charnières et les poser à plat. À l'aide d'un marteau en caoutchouc, placez délicatement la rosette du loquet. Placez le loquet en position. Vissez les blocs porte (F) dans les écrous pré-perçés.

06

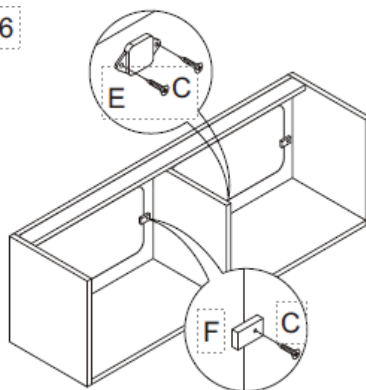

DÉPANNAGE

GUIDE DE RÉOLUTION

QUE FAIRE SI DES PIÈCES MANQUENT À MA COMMANDE ?

S'il manque des pièces à votre commande, veuillez contacter notre équipe du service client dans les 7 jours suivant la réception de votre commande.

QUE FAIRE SI LES VIS NE RENTRENT PAS DANS LES TROUS ?

Il se peut qu'il y ait un peu de sciure/débris à l'intérieur des trous. Veuillez les retirer avant de reprendre l'assemblage. Veuillez utiliser des gants pour retirer les débris, afin d'éviter toute blessures dues aux éclats de bois.

POUR TOUTE AUTRE DEMANDE, VEUILLEZ CONTACTER NOTRE ÉQUIPE DU SERVICE CLIENT.

SPEZIFIKATIONEN

PRODUKTBE SCHREIBUNG

Unsere Monster Camper Hängeschränke wurden entwickelt, um die perfekte Aufbewahrungslösung zu bieten. Wir bieten eine große Auswahl an Größen an, um eine perfekte Passform für Ihr Wohnmobil zu gewährleisten. Diese Schränke sind ideal für jedes Selbstbauprojekt und eine großartige Möglichkeit, zusätzlichen Stauraum in Ihrem Wohnmobil zu schaffen.

PRODUKTSPEZIFIKATIONEN

211119 / 211136

DIMENSIONEN: 1200 x 350 x 350mm

MATERIAL: Birke – Sperrholz

211120

DIMENSIONEN: 1000 x 350 x 350mm

MATERIAL: Birke – Sperrholz

211121

DIMENSIONEN: 800 x 350 x 350mm

MATERIAL: Birke – Sperrholz

211122

DIMENSIONEN: 1200 x 300 x 300mm

MATERIAL: Birke – Sperrholz

211129

DIMENSIONEN: 1000 x 300 x 300mm

MATERIAL: Birke – Sperrholz

211130

DIMENSIONEN: 800 x 300 x 300mm

MATERIAL: Birke – Sperrholz

211133/211137

DIMENSIONEN: 1200 x 250 x 250mm

MATERIAL: Birke – Sperrholz

211134

DIMENSIONEN: 1000 x 250 x 250mm

MATERIAL: Birke – Sperrholz

211135

DIMENSIONEN: 800 x 250 x 250mm







MATERIAL: Birke – Sperrholz

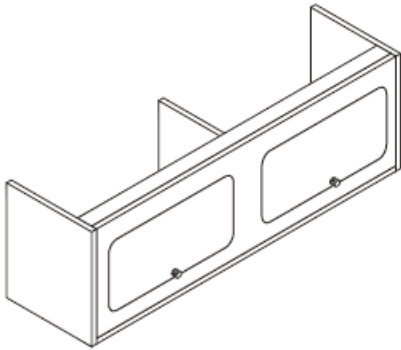

Drei Verbindungsstücke in einem, die drei Teile enthalten - Excenterbeschläge (B), Stahlverbinder (A) und vormontierte Kunststoffmutter (vormontiert). Sie sollten zuerst alle Stahlverbinder montieren, damit sie in die vormontierten Kunststoffmutter passen, ehe Sie den ersten Schritt der Montage vornehmen.

SPEZIFIKATION

ARTIKELINHALT

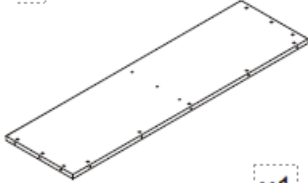
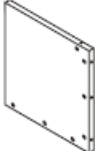
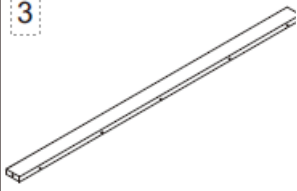
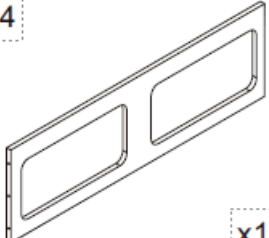
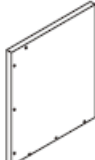
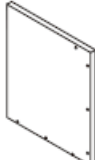

A  x31	B  x31
C  x28	D  x4
E  x2	F  x4

1  x1	2  x1	3  x1
4  x1	5  x1	6  x1
7  x1	8  x1	

SICHERHEITSHINWEISE

SICHERE ARBEITSWEISE

Bitte lesen Sie sich die Hinweise zum sicheren Arbeiten durch, um Verletzungen oder Schäden am Gerät zu vermeiden.

- Um einen korrekten Aufbau des Schrankes zu gewährleisten, empfehlen wir Ihnen, unsere Anweisungen zu befolgen. Die Halterungen müssen mit den vorgebohrten Löchern montiert werden.
- Verwenden Sie dieses Produkt nicht für einen anderen als den vorgesehenen Zweck.
- Vergewissern Sie sich, dass Sie die Gebrauchsanweisung und die Sicherheitshinweise gelesen und verstanden haben, ehe Sie dieses Produkt verwenden.
- Werfen Sie die Packung nicht weg, bevor Sie alle enthaltenen Teile gefunden und bestätigt haben.
- Prüfen Sie das Produkt vor der Installation auf Anzeichen von Schäden und versuchen Sie nicht, das Produkt zu installieren, wenn es beschädigt ist.
- Stellen Sie sicher, dass der Camper Hängeschrank nur in Innenräumen verwendet wird.
- Achten Sie auf einen sauberen Arbeitsbereich.
- In den Vorbohrungen können sich Ablagerungen und/oder Sägespäne befinden. Entfernen Sie diese, bevor Sie mit der Montage beginnen. Benutzen Sie Handschuhe, um sie zu entfernen.
- Wir empfehlen dringend, beim Schneiden, Schleifen oder Bohren dieses Produkts eine Atemschutzmaske (mindestens der Klasse P2) zu tragen, um das Einatmen von gesundheitsschädlichem Staub zu vermeiden.
- Stellen Sie sicher, dass alle Änderungen im Freien und in sicherer Entfernung von anderen Personen vorgenommen werden.

BENUTZERANWEISUNG

MONTAGEANLEITUNG

1. Bringen Sie die Frontplatte (Teil 3) und die Bodenplatte (Teil 1) an der Mittelplatte (Teil 2) an, indem Sie die Excenterbeschläge (B) in die vorgebohrten Kunststoffmuttern schrauben.
2. Schrauben Sie die Scharniere(D) mit den Schrauben(C) in die vorgebohrten Muttern. Passen Sie bei Bedarf die Links-Rechts- oder Oben-Unten-Position an, indem Sie die Schrauben an den Scharnieren anziehen oder lösen, damit die Türen (Teil 7 und Teil 8) richtig positioniert werden können.
3. Bringen Sie die Frontplatte (Teil 4) an der oberen und unteren Platte an.
4. Befestigen Sie die rechte Seitenwand (Teil 6) an der vorderen und unteren

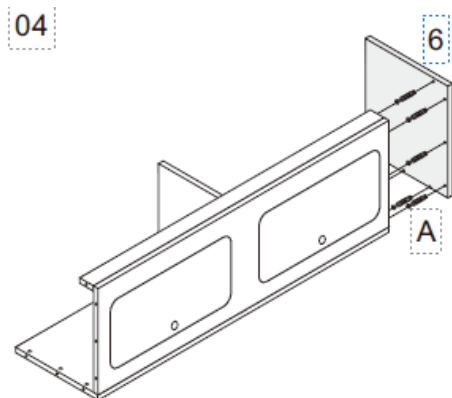
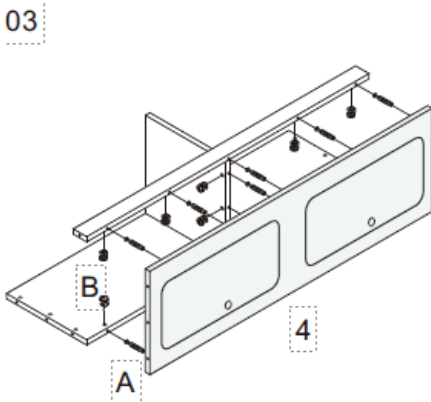
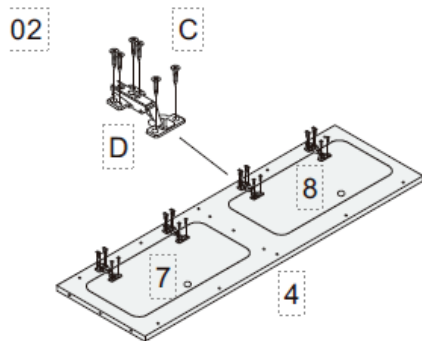
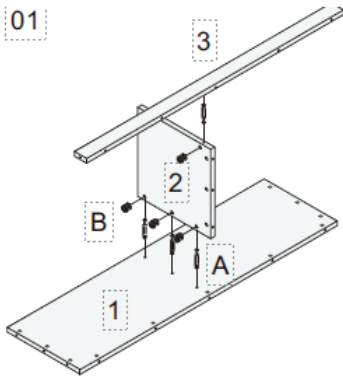

BENUTZERANWEISUNG

MONTAGEANLEITUNG

05

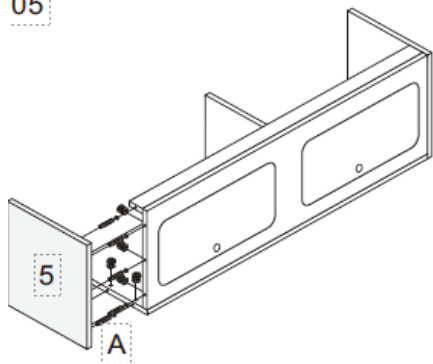

5. Montage der linken Seitenwand (Teil 5) fortsetzen.

6. Wählen Sie die Türfächer (E), indem Sie die Türen von den Scharnieren lösen und sie flach hinlegen. Setzen Sie mit einem Gummihammer vorsichtig die Schlossrosette ein. Setzen Sie die Verriegelung in Position und befestigen Sie sie. Schrauben Sie die Türblöcke (F) in die vorgebohrten Muttern.

06

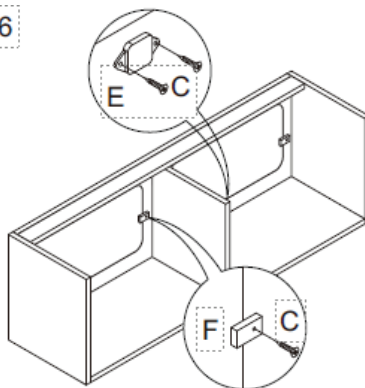

PROBLEMBEHANDLUNG

LÖSUNGSLEITFADEN

WAS MUSS ICH TUN, WENN TEILE MEINER BESTELLUNG FEHLEN?

Sollte bei Ihrer Bestellung ein Teil fehlen, wenden Sie sich bitte innerhalb von 7 Tagen nach Erhalt an unser freundliches und hilfsbereites Kundensupport-Team.

WAS KANN ICH TUN, WENN DIE SCHRAUBEN NICHT IN DIE LÖCHER PASSEN?

In den Öffnungen kann sich etwas Sägemehl/Schmutz befinden. Diese müssen entfernt werden, bevor Sie mit dem Bau beginnen. Benutzen Sie Handschuhe, um die Reste zu entfernen, nur für den Fall, dass Holzsplitter vorhanden sind.

**FÜR ALLE ANDEREN ANLIEGEN WENDEN SIE SICH BITTE AN
UNSEREN KUNDENDIENST.**



ESPECIFICACIONES

DESCRIPCIÓN DEL PRODUCTO

Nuestros armarios superiores de Monster Camper son diseñados para proporcionar la solución de almacenamiento perfecta. Ofrecemos una amplia gama de tamaños para garantizar un ajuste perfecto para su furgoneta Camper. Estos gabinetes son ideales para cualquier proyecto de autoconstrucción y son una excelente manera de agregar almacenamiento adicional en su autocaravana.

ESPECIFICACIONES DEL PRODUCTO

211119 / 211136

DIMENSIONES: 1200 x 350 x 350mm

MATERIAL: Cobertura madera
abedul

211121

DIMENSIONES: 800 x 350 x 350mm

MATERIAL: Cobertura madera
abedul

211129

DIMENSIONES: 1000 x 300 x 300mm

MATERIAL: Cobertura madera
abedul

211133/211137

DIMENSIONES: 1200 x 250 x 250mm

MATERIAL: Cobertura madera
abedul

211135

DIMENSIONES: 800 x 250 x 250mm

MATERIAL: Cobertura madera
abedul

211120

DIMENSIONES: 1000 x 350 x 350mm

MATERIAL: Cobertura madera
abedul

211122

DIMENSIONES: 1200 x 300 x 300mm

MATERIAL: Cobertura madera
abedul

211130

DIMENSIONES: 800 x 300 x 300mm

MATERIAL: Cobertura madera
abedul

211134

DIMENSIONES: 1000 x 250 x 250mm







MATERIAL: Cobertura madera
abeduly

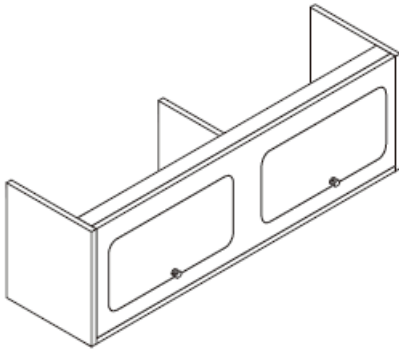

Tres piezas de conexión en una, que contienen tres partes: accesorios (B), conectores de acero (A) y tuercas de plástico previamente instaladas, primero debe montar todos los conectores de acero para que encajen en los preinstalados de plástico.

SPECIFICACIONES

CONTENIDO DE ARTÍCULOS

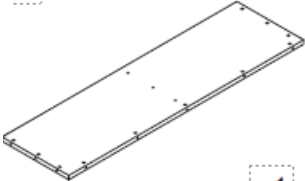
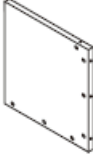
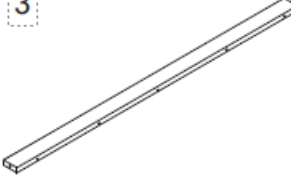
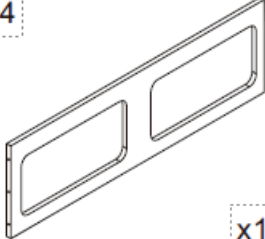
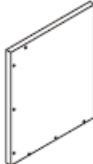
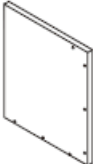

A  x31	B  x31
C  x28	D  x4
E  x2	F  x4

1  x1	2  x1	3  x1
4  x1	5  x1	6  x1
7  x1	8  x1	

CONSEJOS DE SEGURIDAD

Prácticas para un trabajo seguro

Lea estas prácticas de trabajo seguro para garantizar la prevención de lesiones o daños al dispositivo.

- Para asegurarse de que el armario está construido correctamente, le recomendamos que siga nuestras instrucciones, los soportes deben instalarse utilizando orificios pretaladrados.
- No utilice este producto para ningún otro fin que no sea el previsto.
- Asegúrese de haber leído y entendido completamente el manual de instrucciones y los consejos de seguridad antes de usar este producto.
- No deseche el embalaje hasta que haya localizado y confirmado todas las piezas incluidas en el producto.
- Inspeccione el producto en busca de signos de daños antes de la instalación y no intente instalar el producto si está dañado.
- Puede haber escombros y/o aserrín en los orificios pretaladrados. Retire esto antes de comenzar con el montaje. Use guantes para quitarlo.
- Asegúrese de que el armario para caravana solo se utilice en interiores.
- Garantizar un espacio de trabajo limpio para el montaje.
- Recomendamos encarecidamente el uso de equipo de protección personal respiratorio (con clasificación FP2 como mínimo) al cortar, lijar o taladrar este producto para evitar la inhalación de polvo nocivo.
- Asegúrese de que cualquier modificación se realice al aire libre, a una distancia segura de los demás.

GUÍA DEL USUARIO

INSTRUCCIONES DE MONTAJE

1. Coloque el panel frontal (parte 3) y el panel inferior (parte 1) en el panel central (parte 2) atornillando los accesorios (B) en las tuercas de plástico preinstaladas.
2. Atornille las bisagras (D) en tuercas previamente incorporadas usando tornillos (C), si es necesario ajuste la posición izquierda-derecha o arriba-abajo apretando o aflojando los tornillos en las bisagras para asegurar las puertas (parte 7 y parte 8).
3. Coloque el panel frontal (parte 4) en el conjunto del panel superior e inferior.
4. Monte el panel lateral derecho (pieza 6) en el conjunto frontal e inferior.

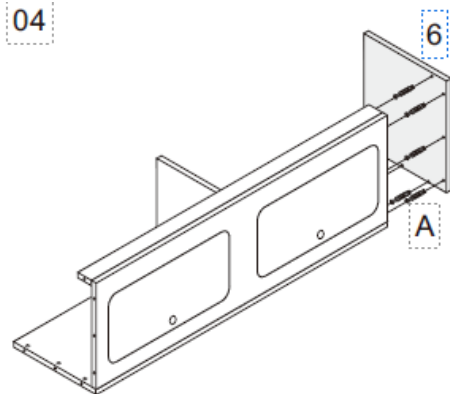
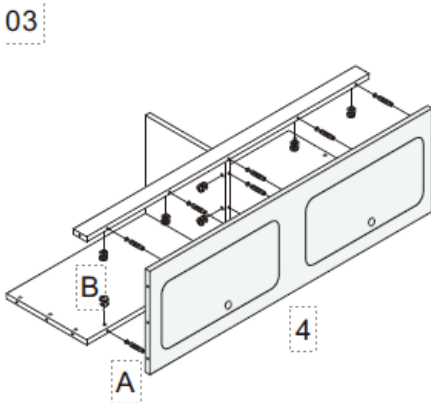
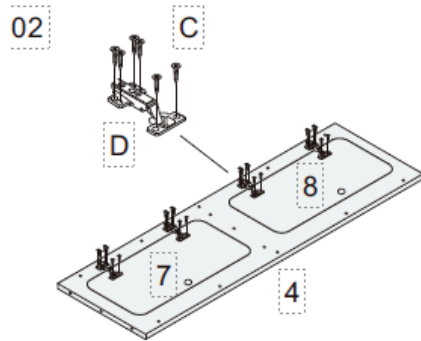
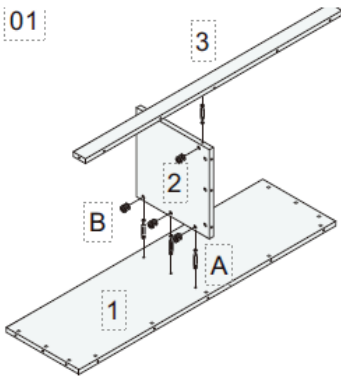

GUÍA DEL USUARIO

INSTRUCCIONES DE MONTAJE

05

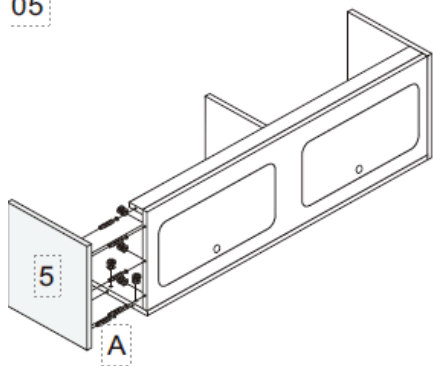

5. Continúe con el montaje del panel lateral izquierda (parte 5).

6. Seleccione los casilleros de las puertas (E). Deberá separar las puertas de las bisagras y colocarlas planas. Usando un martillo de goma, ajuste suavemente la roseta del pestillo. Coloque el pestillo en su posición y ajuste en su lugar. Atornille los bloques de puerta (F) en tuercas previamente instaladas

06

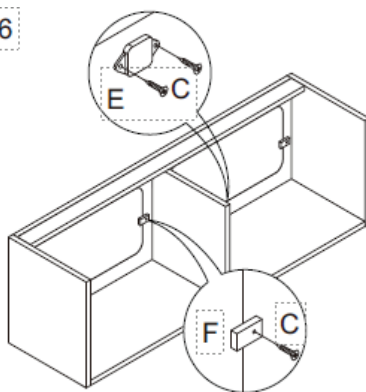

SOLUCIÓN DE PROBLEMAS

GUÍA DE RESOLUCIÓN

¿QUÉ HAGO SI FALTAN PIEZAS DE MI PEDIDO?

Si parece que falta alguna pieza en su pedido, comuníquese con nuestro equipo de atención al cliente dentro de los 7 días posteriores a la recepción.

¿QUÉ HAGO SI LOS TORNILLOS NO CABEN EN LOS AGUJEROS?

Puede haber algo de aserrín/residuos en los agujeros. Esto deberá eliminarse antes de que se reinicie la construcción. Use guantes para eliminar cualquier residuo, en caso de que haya astillas de madera.

PARA OTROS PROBLEMAS, POR FAVOR CONTACTE A NUESTRO EQUIPO DE ATENCIÓN AL CLIENTE.

SPECIFICHE

DESCRIZIONE DEL PRODOTTO

Il nostri pensili sopraelevati Monster per camper sono concepiti per fornire una perfetta soluzione di stoccaggio. Offriamo un'ampia gamma di misure per garantire il migliore adattamento alla grandezza del vostro camper. Questi armadietti sono ideali per qualsiasi progetto dicostruzione in proprio e rappresentano un ottimo modo per aggiungere ulteriore spazio al vostro camper.

SPECIFICHE DEL PRODOTTO

211119 / 211136

DIMENSIONI: 1200 x 350 x 350mm
MATERIALE: Legno di betulla Ply

211120

DIMENSIONI: 1000 x 350 x 350mm
MATERIALE: Legno di betulla Ply

211121

DIMENSIONI: 800 x 350 x 350mm
MATERIALE: Legno di betulla Ply

211122

DIMENSIONI: 1200 x 300 x 300mm
MATERIALE: Legno di betulla Ply

211129

DIMENSIONI: 1000 x 300 x 300mm
MATERIALE: Legno di betulla Ply

211130

DIMENSIONI: 800 x 300 x 300mm
MATERIALE: Legno di betulla Ply

211133/211137

DIMENSIONI: 1200 x 250 x 250mm
MATERIALE: Legno di betulla Ply

211134

DIMENSIONI: 1000 x 250 x 250mm
MATERIALE: Legno di betulla Ply

211135

DIMENSIONI: 800 x 250 x 250mm
MATERIALE: Legno di betulla Ply

Tre pezzi di collegamento in uno, che contengono tre parti: raccordi di fissaggio (B), connettori in acciaio (A) e dadi in plastica prefissati (preassemblati); è necessario assemblare tutti i connettori in acciaio e inserirli nei dadi in plastica prefissati prima di procedere al primo montaggio.

SPECIFICHE TECNICHE

PEZZI INCLUSI

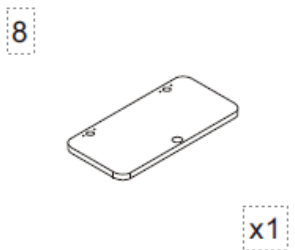
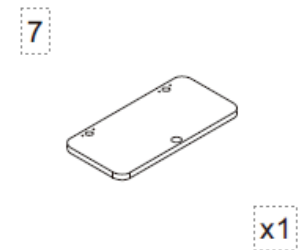
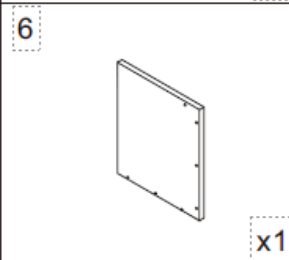
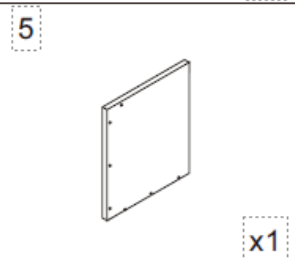
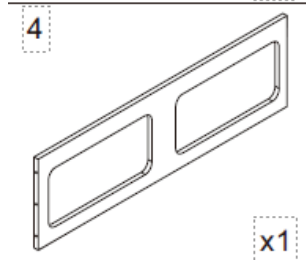
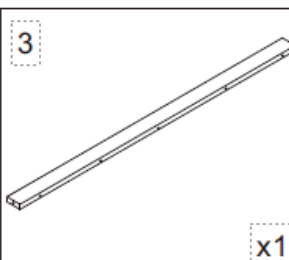
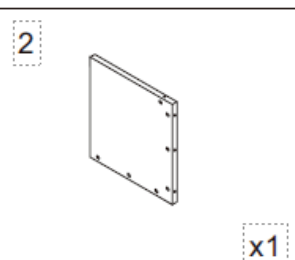
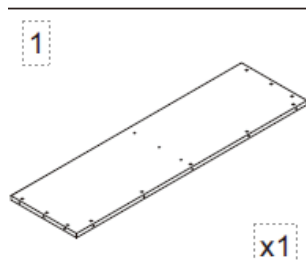
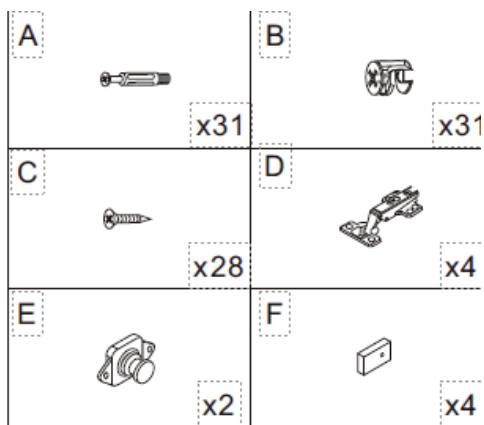
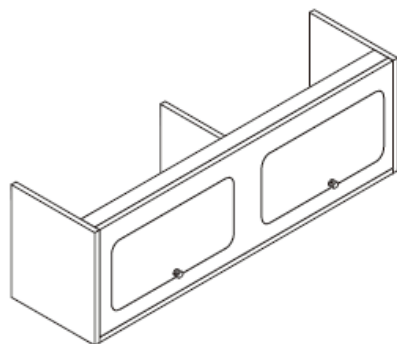

AVVISO DI SICUREZZA

PRASSI DI LAVORO SICURO

Si prega di leggere le seguenti istruzioni per prevenire infortuni o danni agli oggetti.

- Per garantire una corretta installazione del mobile, consigliamo di seguire le istruzioni da noi indicate; le mensole devono essere installate utilizzando i fori già esistenti.
- Non utilizzare questo prodotto per scopi diversi da quelli previsti.
- Verificate di aver letto e compreso appieno il manuale di istruzioni e i consigli sulla sicurezza prima di utilizzare il prodotto.
- Non gettare l'imballaggio prima di aver individuato e confermato la presenza di tutte le parti incluse.
- Prima dell'installazione, verificate l'assenza di segni di danneggiamento e non tentare di installarlo se sono presenti.
- È possibile la presenza di detriti e/o segatura nei fori già esistenti. Rimuovete prima di iniziare il montaggio utilizzando guanti.
- Assicuratevi di utilizzare il mobiletto per camper solo in ambienti chiusi.
- Assicuratevi di lavorare in uno spazio pulito.
- Si raccomanda vivamente l'utilizzo di maschere DPI (minimo P2) quando si taglia, si carteggia o si fora questo prodotto, per evitare l'inalazione di polveri nocive.
- Assicuratevi di eseguire eventuali modifiche all'aria aperta, a distanza di sicurezza da altre persone.

GUIDA ALL'USO

ISTRUZIONI PER IL MONTAGGIO

1. Montate il pannello anteriore (parte 3) e il pannello inferiore (parte 1) sul pannello centrale (parte 2) avvitando i raccordi (B) nei dadi di plastica prefissati.
2. Avvitare le cerniere (D) nei dadi prefissati utilizzando le viti (C); se necessario, regolate la posizione a sinistra/destra o basso/alto, stringendo o allentando le viti sulle cerniere per garantire che le porte (parte 7 e parte 8) possano essere posizionate correttamente.
3. Montate il pannello frontale (parte 4) sul pannello superiore e inferiore.
4. Montate il pannello laterale destro (parte 6) sul pannello anteriore e inferiore.

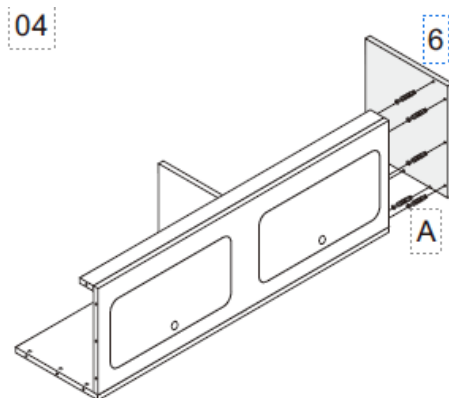
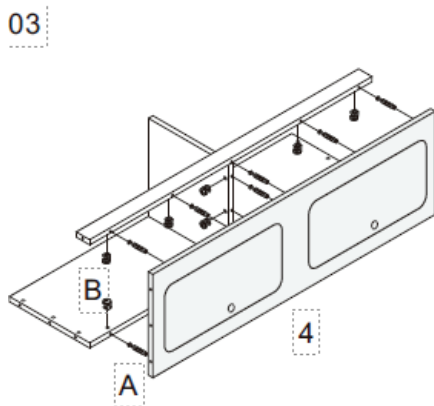
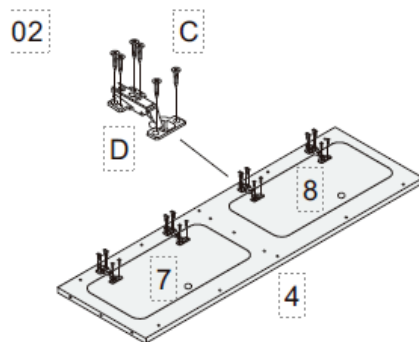
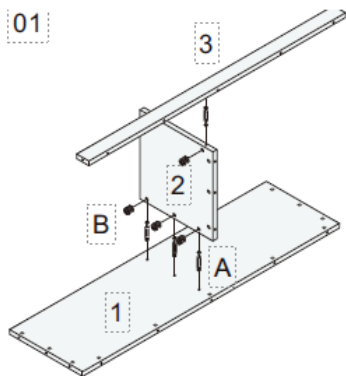

GUIDA ALL'USO

ISTRUZIONI PER IL MONTAGGIO

05

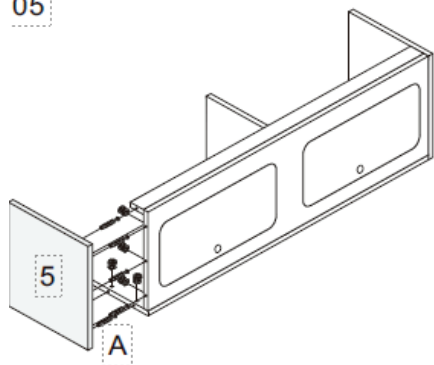

5. Procedete allo stesso modo con il pannello laterale sinistro (parte 5).

6. Selezionate le chiusure (E) necessarie per staccare le ante dalle cerniere e appoggiare le ante in piano. Utilizzando un martello in gomma, montate delicatamente la rosetta della chiusura. Posizionate la chiusura nella posizione corretta e incastrarla.

Avvitare le chiusure (F) nei dadi prefissati.

06

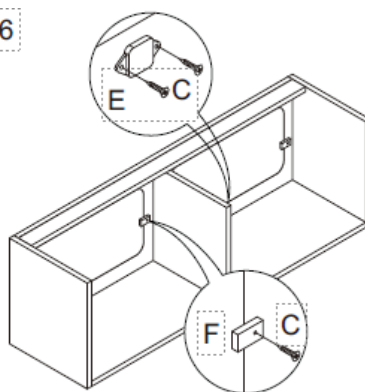

RISOLUZIONE DEI PROBLEMI

GUIDA ALLA RISOLUZIONE DEI PROBLEMI

COSA DEVO FARE SE MANCANO DEI PEZZI AL MIO ORDINE?

Se avete l'impressione che manchi qualche oggetto all'interno del vostro ordine, contattate il nostro amichevole e disponibile servizio di Assistenza Clienti entro 7 giorni dalla consegna del prodotto.

COSA DEVO FARE SE LE VITI NON ENTRANO NEI FORI?

Nei fori potrebbero essere presenti segatura e detriti. Dovranno essere rimossi prima di proseguire con la costruzione. Utilizzate guanti per rimuovere i detriti, nel caso in cui siano presenti schegge di legno.

**PER QUALSIASI ALTRA PROBLEMATICHE, SI PREGA DI
CONTATTARE
IL NOSTRO SERVIZIO DI ASSISTENZA CLIENTI.**

SPECIFICATIE

PRODUCT OMSCHRIJVING

Onze Monster Camper bovenkasten zijn ontworpen om de perfecte opslagoplossing te bieden. We bieden een breed scala aan maten om een perfecte pasvorm voor jouw camper te garanderen. Deze kasten zijn ideaal voor elk zelfbouwproject en zijn een geweldige manier om extra opbergruimte toe te voegen aan je camper.

PRODUCTSPECIFICATIES

211119 / 211136

AFMETINGEN: 1200 x 350 x 350mm

MATERIAAL: Beuken multiplex

211120

AFMETINGEN: 1000 x 350 x 350mm

MATERIAAL: Beuken multiplex

211121

AFMETINGEN: 800 x 350 x 350mm

MATERIAAL: Beuken multiplex

211122

AFMETINGEN: 1200 x 300 x 300mm

MATERIAAL: Beuken multiplex

211129

AFMETINGEN: 1000 x 300 x 300mm

MATERIAAL: Beuken multiplex

211130

AFMETINGEN: 800 x 300 x 300mm

MATERIAAL: Beuken multiplex

211133/211137

AFMETINGEN: 1200 x 250 x 250mm

MATERIAAL: Beuken multiplex

211134

AFMETINGEN: 1000 x 250 x 250mm

MATERIAAL: Beuken multiplex

211135

AFMETINGEN: 800 x 250 x 250mm





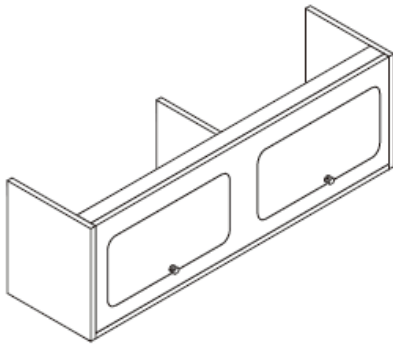

MATERIAAL: Beuken multiplex

Bij drie in-één verbindingsstukken, die drie onderdelen bevatten: excentrische hulpstukken (B), stalen aansluitingen (A) en plastieke voorverzonken moeren (voorgemonteerd), moet je voordat je met stap 1 begin alle stalen aansluitingen in elkaar zetten zodat ze passen in vooraf ingegraven plastieke moeren.

SPECIFICATIE

ITEM INHOUD



A  x31	B  x31
C  x28	D  x4
E  x2	F  x4

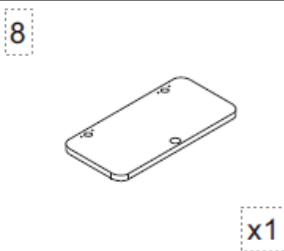
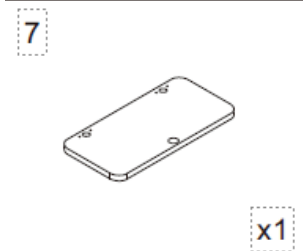
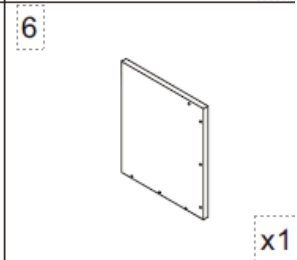
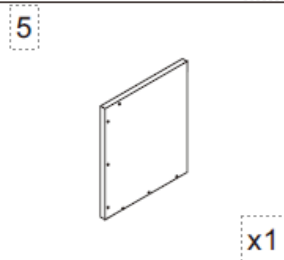
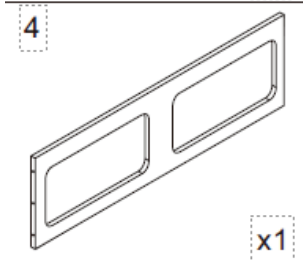
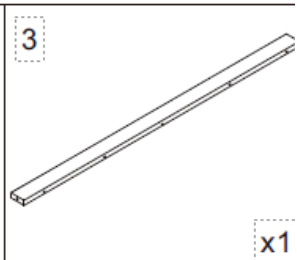
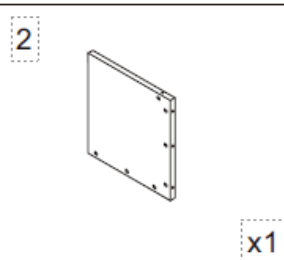
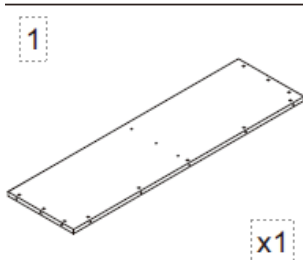

VEILIGHEIDSADVIJES

VEILIG GEBRUIK

Lees het veiligheidsadvies door om letsel of schade aan het apparaat te voorkomen.

- Om ervoor te zorgen dat de kast correct wordt gebouwd raden we aan onze instructies te volgen, beugels moeten worden geïnstalleerd met behulp van voorgeboorde gaten.
- Gebruik dit product niet voor iets anders dan waarvoor het bedoeld is.
- Zorg ervoor dat je de gebruiksaanwijzing en het veiligheidsadvies volledig gelezen en begrepen hebt voordat je dit product gebruikt.
- Gooi de verpakking niet weg voordat alle meegeleverde onderdelen zijn gevonden en bevestigd.
- Inspecteer het product vóór installatie op tekenen van schade en probeer het product niet te installeren als het beschadigd is.
- Er kan vuil en/of zaagsel in de voorgeboorde gaten zitten. Verwijder deze voordat je met de montage begint. Gebruik handschoenen om het te verwijderen.
- Zorg ervoor dat de camperkast alleen binnenshuis wordt gebruikt.
- Zorg voor een schone werkruimte.
- We raden ten zeerste aan om adembeschermingsmiddelen (minimaal P2) te gebruiken bij het zagen, schuren of boren van dit product om inademing van schadelijk stof te voorkomen.
- Zorg ervoor dat eventuele wijzigingen in de open lucht worden aangebracht, op veilige afstand van anderen.

HANDLEIDING

MONTAGEINSTRUCTIES

1. Monteer het voorpaneel (deel 3) en het bodempaneel (deel 1) op het middenpaneel (deel 2) door excentrische fittingen (B) in kunststof voorgegraven moeren te schroeven.
2. Schroef de scharnieren (D) in voorgegraven moeren met behulp van schroeven (C), pas indien nodig de positie links-rechts of omhoog-omlaag aan door de schroeven op de scharnieren vaster of losser te draaien om te verzekeren dat de deuren (deel 7 en deel 8) goed gepositioneerd kunnen worden.
3. Monteer het voorpaneel (deel 4) op het boven- en onderpaneel.
4. Monteer het rechter zijpaneel (onderdeel 6) op de voor- en onderconstructie.

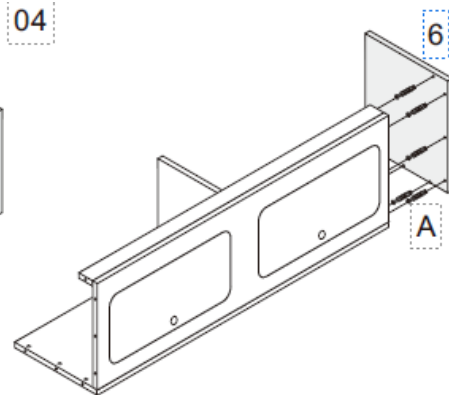
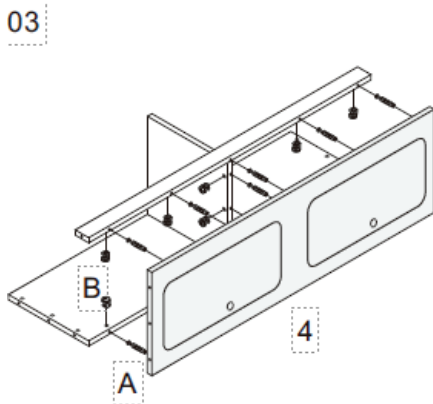
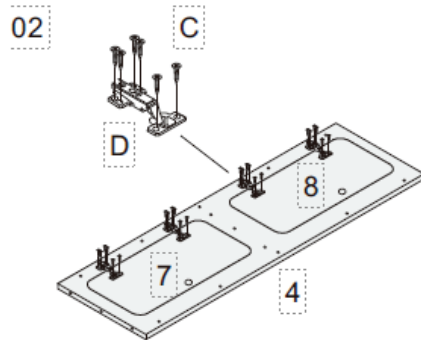
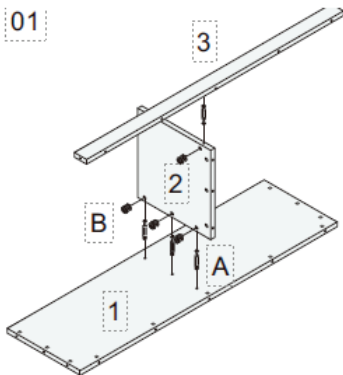

HANDLEIDING

MONTAGEINSTRUCTIES

05

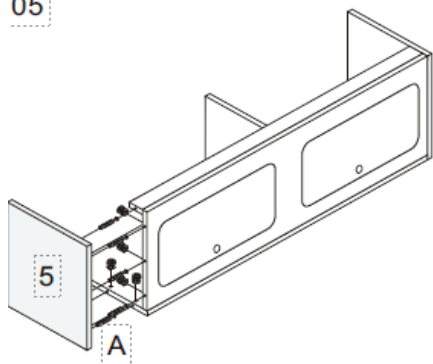

5. Ga verder met het monteren van het linker zijpaneel (deel 5).

6. Pak de onderdeeljes (E) die je nodig hebt om de deuren uit de scharnieren te halen en leg de deuren plat neer. Gebruik een rubberen hamer om de vergrendelingsrozet voorzichtig te plaatsen. Plaats de vergrendeling op zijn plaats en zet deze vast. Schroef deurblokken (F) in voorgegraven moeren.

06

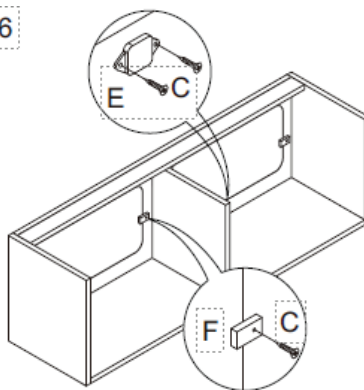

PROBLEEM OPLOSSEN

OPLOSSINGEN

WAT MOET IK DOEN ALS ER ONDERDELEN ONTBREKEN IN MIJN BESTELLING?

Neem als er een onderdeel van je bestelling lijkt te ontbreken binnen 7 dagen na ontvangst contact op met onze vriendelijke en behulpzame klantenservice.

WAT MOET IK DOEN ALS DE SCHROEVEN NIET IN DE GATEN PASSEN?

Er kan wat zaagsel/vuil in de gaten zitten. Dit moet worden verwijderd voordat de bouw wordt hervat. Gebruik handschoenen om vuil te verwijderen voor het geval er houtsplinters aanwezig zijn.

**NEEM VOOR ALLE OVERIGE KWESTIES CONTACT OP MET ONZE
KLANTENSERVICE**



SPECIFIKATION

PRODUKT BESKRIVNING

Våra överskåp för husbilar är designade för att förse en perfekt förvaringslösning. Vi erbjuder ett brett utbud av storlekar för att säkerställa en perfekt passform för din husbil. Dessa skåp är idealiska för alla gör-det-själv-projekt och är ett utmärkt sätt att lägga till ytterligare förvaring i din husbil.

PRODUKTSPECIFIKATIONER

211119 / 211136

MÅTT: 1200 x 350 x 350mm

MATERIAL: Plywood av björkträ

211120

MÅTT: 1000 x 350 x 350mm

MATERIAL: Plywood av björkträ

211121

MÅTT: 800 x 350 x 350mm

MATERIAL: Plywood av björkträ

211122

MÅTT: 1200 x 300 x 300mm

MATERIAL: Plywood av björkträ

211129

MÅTT: 1000 x 300 x 300mm

MATERIAL: Plywood av björkträ

211130

MÅTT: 800 x 300 x 300mm

MATERIAL: Plywood av björkträ

211133/211137

MÅTT: 1200 x 250 x 250mm

MATERIAL: Plywood av björkträ

211134

MÅTT: 1000 x 250 x 250mm

MATERIAL: Plywood av björkträ

211135

MÅTT: 800 x 250 x 250mm







MATERIAL: Plywood av björkträ

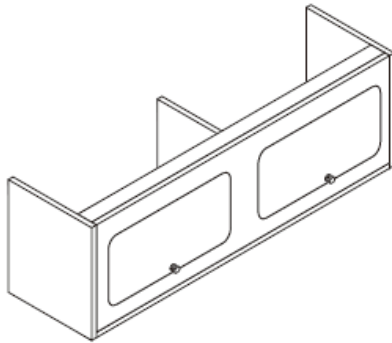

Tre i-ett anslutningsstycken, som innehåller tre delar - excenterkopplingar (B), stålkopplingar (A) och förmonterade plastmuttrar, du bör först montera alla stålkopplingar så att de passar in i de förmonterade plastmuttrarna innan första steget.

SPECIFIKATION

ARTIKELNS INNEHÅLL

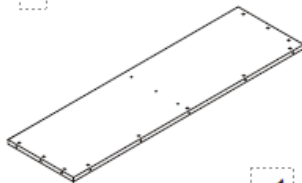
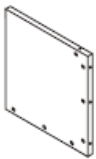
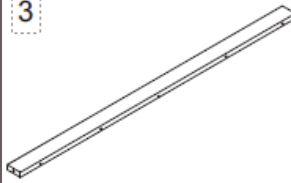
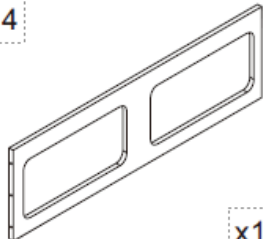
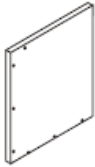
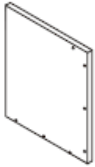

A  x31	B  x31
C  x28	D  x4
E  x2	F  x4

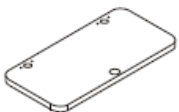
1  x1	2  x1	3  x1
4  x1	5  x1	6  x1
7  x1	8  x1	

SÄKERHETSÅD

SÅKER ARBETSÅRAXIS

VÅnligan lÅs igenom SÅker Arbetspraxis fÅr att sÅkerstÅlla att kroppsliga skador eller skador pÅ enheten fÅrhindras.

- FÅr att sÅkerstÅlla att skÅpet År korrekt monterat rekommenderar vi att du fÅljer vÅra instruktioner, fÅsten mÅste installeras med hjÅlp av fÅrborrade hÅl.
- AnvÅnd inte denna produkt fÅr nÅgot annat Ån dess avsedda ÅndamÅl.
- Se till att du har lÅst och till fullo fÅrstÅtt bruksanvisningen och sÅkerhetsrÅden innan du anvÅnder denna produkt.
- Kasta inte fÅrpackningen fÅrrÅn alla medfÅljande delar har hittats och bekrÅftats.
- Inspektera produkten fÅr tecken pÅ skada innan installation och fÅrsÅk inte installera produkten om den År skadad.
- Det kan finnas skrÅp och/eller sÅgspÅn i de fÅrborrade hÅlen. AvlÅgsna detta innan du bÅrjar med monteringen. AnvÅnd handskar fÅr att avlÅgsna detta.
- Se till att husbilsskÅpet endast anvÅnds inomhus.
- SÅkerstÅll en ren arbetsyta.
- Det kan finnas skrÅp och sÅgspÅn i de fÅrborrade hÅlen. Ta bort detta innan du bÅrjar med monteringen. AnvÅnd handskar fÅr att ta bort den.
- Vi rekommenderar starkt anvÅndning av andningsssydd (klassad P2 som minimum) vid skÅrning, slipning eller borring av denna produkt fÅr att fÅrhindra inandning av skadligt damm.
- Se till att alla Åndringar gÅrs utomhus, pÅ ett sÅkert avstÅnd frÅn andra.

ANVÄNDARGUIDE

MONTERINGSANVISNINGAR

1. Montera frontpanelen (del 3) och bottenpanelen (del 1) på mittpanelen (del 2) genom att skruva in excenterkopplingar (B) i de förmonterade plastmuttrarna.
2. Skruva in gångjärnen (D) i de förmonterade muttrarna med skruvar (C), justera vid behov vänster-höger- eller upp-ned-läget genom att dra åt eller lossa skruvarna på gångjärnen för att säkerställa att dörrarna (del 7 och del 8) placeras korrekt.
3. Montera frontpanelen (del 4) på den övre och nedre panelenheten.
4. Montera den högra sidopanelen (del 6) på den främre och nedre delen.

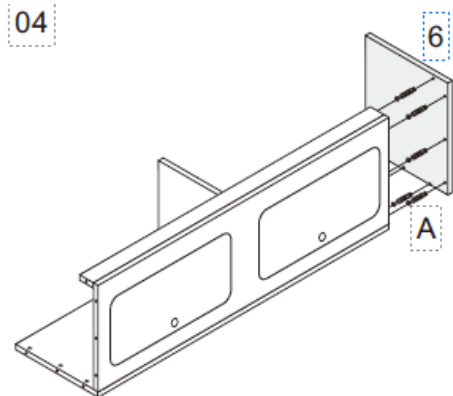
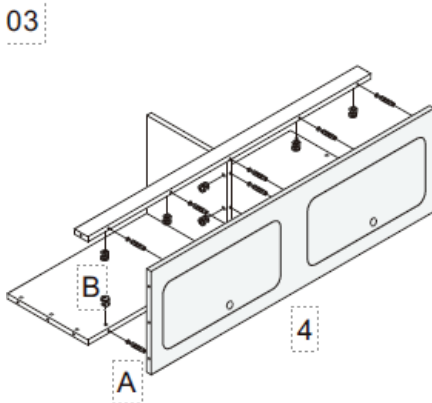
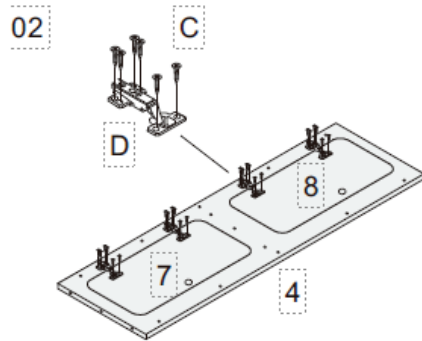
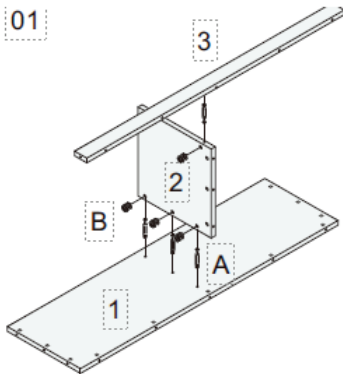

ANVÄNDARGUIDE

MONTERINGSANVISNINGAR

05

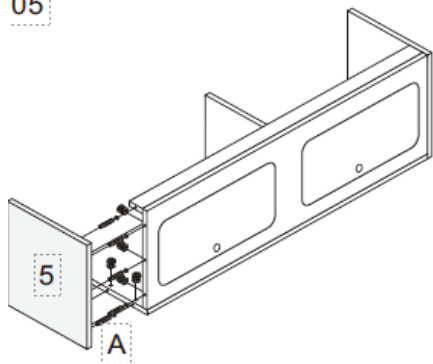

5. Fortsätt med att montera den vänstra sidopanelen (del 5).

6. Välj dörrlås (E) du behöver avlägsna dörrarna från gångjärnen och lägga dörrarna plant. Använd en gummihammare för att försiktigt montera spärren. Sätt spärren på plats och fäst. Skruva fast dörrblocken (F) i de förmonterade muttrarna

06

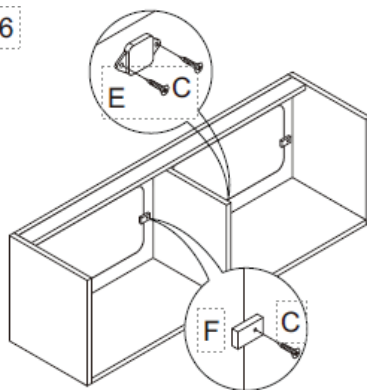

FELSÖKNING

FELSÖKNINGSGUIDE

VAD GÖR JAG OM DET SAKNAS DELAR I MIN BESTÄLLNING?

Om det verkar finnas någon del som saknas i din beställning, kontakta vårt vänliga och hjälpsamma kundsupportteam inom 7 dagar efter mottagandet.

VAD GÖR JAG OM SKRUVAR INTE KOMMER I PASSA I HÅLEN?

Det kan finnas lite sågspån/skräp i hålen. Detta kommer att behöva tas bort innan byggnaden återupptas. Använd handskar för att ta bort skräp, ifall det finns träsplitter.

**FÖR ALLA ANDRA FRÅGOR, KONTAKTA VÅRT
KUNDSUPPORTTEAM.**

Monster Group (UK) is one of the UK's fastest growing online retailers. We supply a diverse range of products which offer exceptional value for money. We strive to provide the best possible customer experience with free UK delivery across all our products and a Monster Guarantee for 100% satisfaction.

For information regarding this device or other products from our Monster divisions please contact Sales.

SALES

TEL: 01347 878 888

EMAIL: hello@monstershop.co.uk

For queries about this device, warranty, returns or reporting faults please contact Support.

SUPPORT

TEL: 01347 878 887

EMAIL: help@monstershop.co.uk

Pour plus d'informations concernant cet appareil ou d'autres produits de nos divisions de Monster veuillez utiliser les détails suivants ci-dessous.

DÉPARTEMENT COMMERCIAL

TEL: 01347 878 888

EMAIL: bonjour@monstershop.eu

Pour les interrogations concernant cet appareil, la garantie, les retours ou les défauts de déclaration veuillez utiliser les détails suivants ci-dessous.

DÉPARTEMENT DE SOUTIEN

TEL: 01347 878 887

EMAIL: help@monstershop.co.uk

Para información sobre este dispositivo u otros productos de nuestras divisiones de Monster por favor use los siguientes detalles.

DEPARTAMENTO DE VENTAS

TEL: 01347 878 888

EMAIL: hola@monstershop.eu

Para consultas sobre este dispositivo, la garantía, devoluciones o denuncias de fallos por favor use los siguientes detalles.

DEPARTAMENTO DE SOPORTE

TEL: 01347 878 887

EMAIL: help@monstershop.co.uk

Für Informationen bezüglich dieses Geräts oder anderer Produkte aus unserer Monster-Abteilung, benutzen sie die folgenden unten aufgeführten Angaben.

VERKAUFABTEILUNG

TEL: 01347 878 888

EMAIL: hallo@monstershop.eu

Für Fragen über dieses Gerät, die Garantie, Rückgaben oder bei Störungen, benutzen sie die folgenden unten aufgeführten Angaben.

SUPPORT-ABTEILUNG

TEL: 01347 878 887

EMAIL: help@monstershop.co.uk

Per informazioni riguardanti questo dispositivo o altri prodotti dalle categorie Monster utilizzare i dettagli sotto riportati.

DIPARTIMENTO VENDITE

TEL: 01347 878 888

EMAIL: ciao@monstershop.eu

Per domande riguardo dispositivo, garanzia, reso o per riferire di guasti, utilizzare i dettagli sotto riportati.

DIPARTIMENTO SUPPORTO

TEL: 01347 878 887

EMAIL: help@monstershop.co.uk

Monster House, Alan Farnaby Way,
Sheriff Hutton Industrial Estate,
Sheriff Hutton, York, YO60 6PG
www.monstershop.co.uk



 Try **Monster**. Buy **Monster**. Be **Monster**. 