

Rattan Cushion Storage Box & Bag

212733 / 212734 / 212735

INSTRUCTION MANUAL

www.monstershop.co.uk



SPECIFICATION

PRODUCT DESCRIPTION















Our Rattan Cushion Storage Box & Bag is designed to provide durable and waterproof storage for your cushions, during winter or rainy months.

As part of our Jardi Signature Collection, this storage box will fit all of the cushions from the Rattan Corner Set, perfectly! The super handy storage bag is included to make it quick and easy for you to transport your cushions from your furniture to storage - no more awkward stacking of cushions!

PRODUCT SPECIFICS

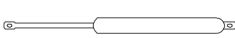
DIMENSIONS: 138cm (H) x 68cm (W) x 80cm (D)
WEIGHT: 15kg
CAPACITY: 720L

ITEM CONTENTS

A		1PC	H	 M6*35	14PCS
B		1PC	I	 M6*30	2PCS
C		2PCS	J	 M6*20	8PCS
D		1PC	K		24PCS
E		1PC	L		1PC
F		2PCS	M		1PC
G		6PCS	N		2PCS

USER GUIDE

ASSEMBLY INSTRUCTIONS

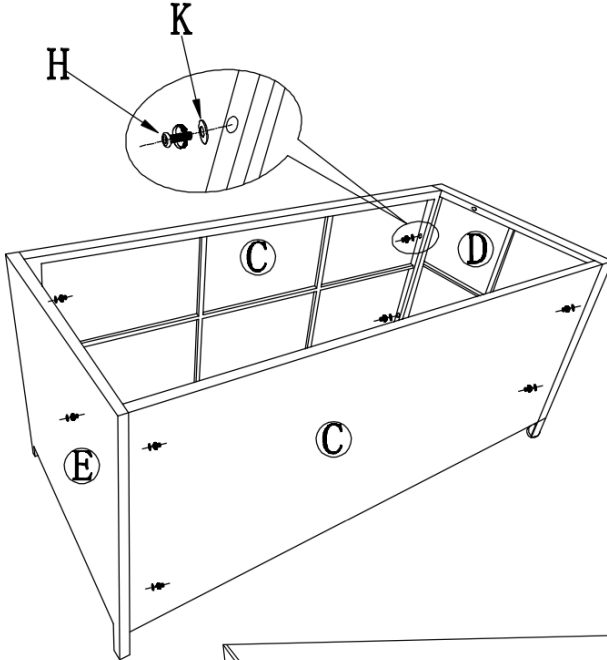

Start by screwing together the box. Take pieces (C), (E) and (D) and attach them to one another as shown in this diagram.

Use the (H) screws and the (K) washers for this. Each corner has 2 holes for the screws to go in.

Next, attach the (B) piece to the bottom of the now-created box. Use the same screws and washers as before.

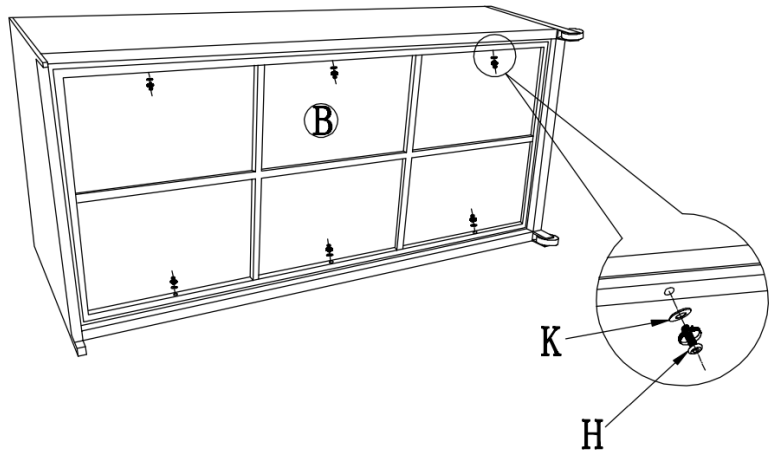

Monster Group UK Limited's liability will be limited to the commercial value of the product only.

USER GUIDE

ASSEMBLY INSTRUCTIONS

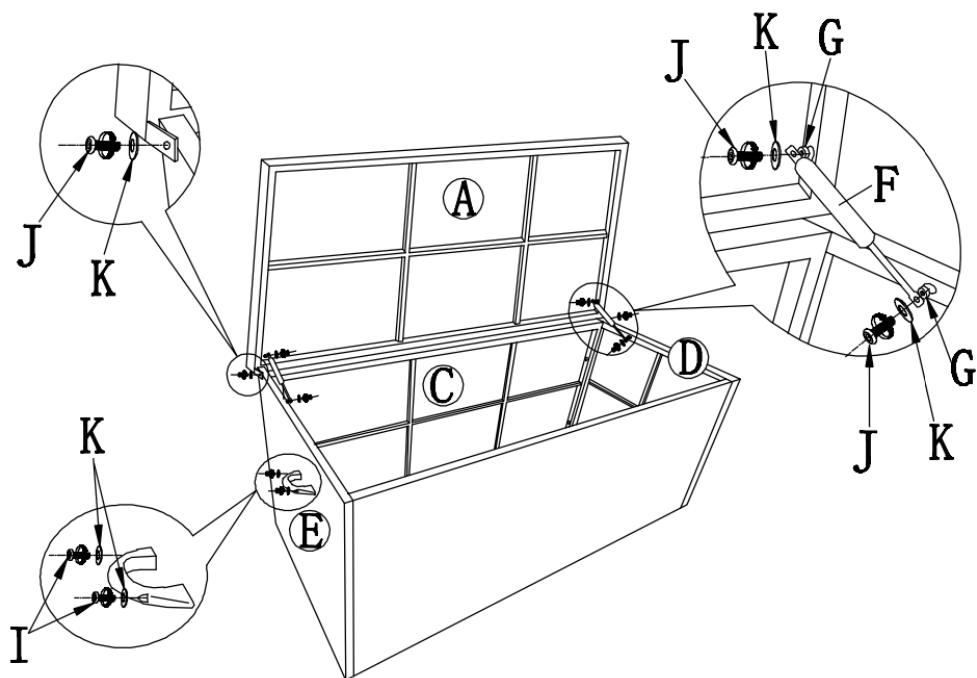

To attach the box lid, take piece (A) and place it on top of the box. With the lid open, screw pieces (F) and (G) in place on the inside of the box according to the diagram, by using the (J) screws and (K) washers. Piece (G) goes under piece (F).

Screw the handle (M) into place, by using screws (I) and washers (K), on the (E) side of the box.

MAINTENANCE

- The Rattan Storage Box should be stored indoors for adverse weather conditions including heavy rain and low temperatures.
- Ensure cushions are fully dry before storing in the bag & box, to avoid potential growth of mould or mildew.
- Check screws and bolts regularly to ensure the product is maintaining its sturdiness.

SAFETY ADVICE

SAFE WORKING PRACTICE

- Do not use this product for anything other than its intended purposes. This product is not designed to be used as a seat.
- Ensure you have read and fully understood the instruction manual and safety advice before using this product.
- We recommend that at least two people work together for the assembly.
- Keep small parts away from children.
- Ensure this product is fitted correctly.
- Use this product on a flat surface.
- Do not expose this product to fire.
- Do not allow this product to get excessively hot.

TROUBLESHOOTING

RESOLUTION GUIDE

WHAT DO I DO IF THERE ARE MISSING PARTS FROM MY ORDER?

If there appears to be any part missing from your order, contact our friendly and helpful Customer Support Team within 7 days of receipt.

**FOR ALL OTHER ISSUES, PLEASE CONTACT OUR
CUSTOMER SUPPORT TEAM.**

SPÉCIFICATIONS

DESCRIPTION DU PRODUIT















Notre boîte de stockage pour coussins en rotin est conçue pour offrir un rangement durable et imperméable pour vos coussins, pendant l'hiver ou les mois de pluie.

Faisant partie intégrale de notre Collection Signature Jardí, cette boîte conviendra parfaitement à tous les coussins du salon d'angle en rotin ! Le sac de rangement super pratique est inclus pour vous permettre de transporter rapidement et facilement vos coussins de vos meubles d'un endroit à l'autre - fini l'empilement maladroit de coussins!

DÉTAILS DU PRODUIT

DIMENSIONS:	138cm (H) x 68cm (L) x 80cm (P)
POIDS:	15kg
CAPACITÉ:	720L

LISTE DES PIÈCES

A		1PC	H	 M6*35	14PCS
B		1PC	I	 M6*30	2PCS
C		2PCS	J	 M6*20	8PCS
D		1PC	K		24PCS
E		1PC	L		1PC
F		2PCS	M		1PC
G		6PCS	N		2PCS

MODE D'EMPLOI

INSTRUCTIONS DE MONTAGE

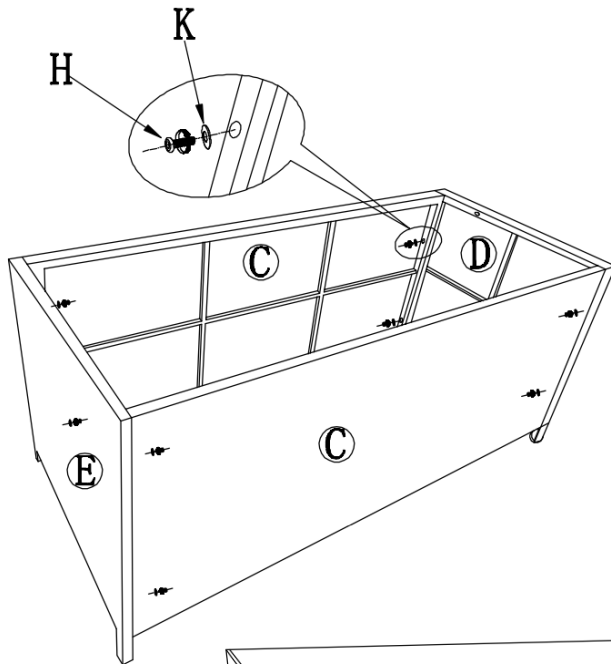

Commencez par visser ensemble la boîte. Prenez les pièces (C), (E) et (D) et attachez-les les unes aux autres comme indiqué dans ce schéma.

Utilisez les vis (H) et les rondelles (K) pour cela. Chaque coin a 2 trous pour que les vis puissent entrer.

Ensuite, fixez la pièce (B) au bas de la boîte nouvellement créée. Utilisez les mêmes vis et rondelles qu'auparavant.

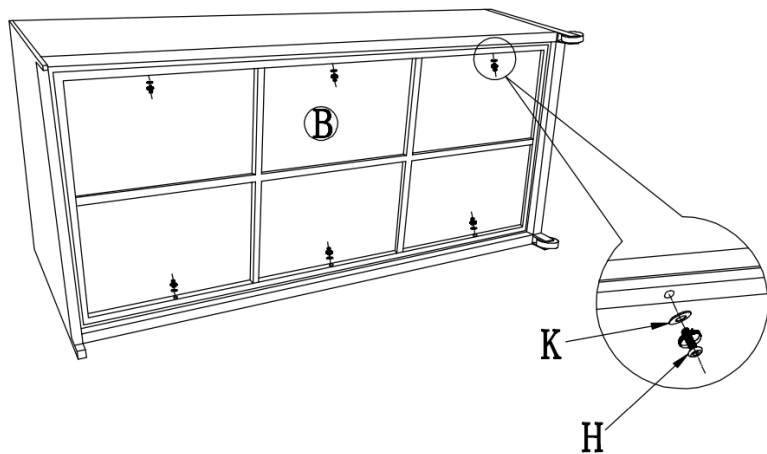

La responsabilité de Monster Group UK Limited sera limitée à la valeur commerciale du produit.

MODE D'EMPLOI

INSTRUCTIONS DE MONTAGE

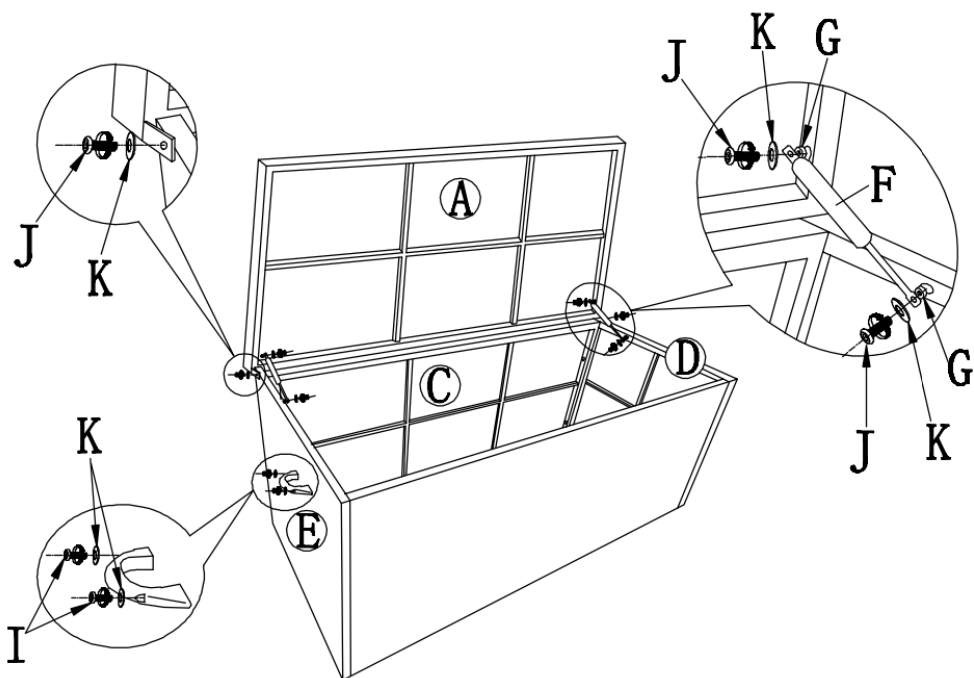

Pour fixer le couvercle de la boîte, prenez la pièce (A) et placez-la sur le dessus de la boîte. Avec le couvercle ouvert, vissez les pièces (F) et (G) en place à l'intérieur de la boîte selon le schéma, en utilisant les vis (J) et les rondelles (K). La pièce (G) va sous la pièce (F).

Vissez la poignée (M) en place, en utilisant les vis (I) et les rondelles (K), sur le côté (E) de la boîte.

ENTRETIEN

- La boîte de rangement en rotin doit être stockée à l'intérieur en cas de conditions météorologiques défavorables, y compris de fortes pluies et de basses températures.
- Assurez-vous que les coussins sont complètement secs avant de les ranger dans le sac ou la boîte, pour éviter tout risque de développement de moisissures ou de champignons.
- Vérifiez régulièrement les vis et les boulons pour vous assurer que le produit maintient sa robustesse.

CONSEILS DE SÉCURITÉ

PRATIQUE DE TRAVAIL SÉCURITAIRE

- N'utilisez pas ce produit pour autre chose que ses usages prévus. Ce produit n'est pas conçu pour être utilisé comme siège.
- Assurez-vous d'avoir lu et compris pleinement le manuel d'instructions et les conseils de sécurité avant d'utiliser ce produit.
- Nous recommandons que au moins deux personnes travaillent ensemble pour l'assemblage.
- Gardez les petites pièces hors de la portée des enfants.
- Assurez-vous que ce produit est correctement installé.
- Utilisez ce produit sur une surface plane.
- N'exposez pas ce produit au feu.
- Ne permettez pas à ce produit de devenir excessivement chaud.

DÉPANNAGE

GUIDE DE RÉOLUTION

QUE FAIRE S'IL MANQUE DES PIÈCES À MA COMMANDE?

S'il semble manquer des pièces à votre commande, contactez notre équipe du service client dans les 7 jours suivant la réception.

**POUR TOUT AUTRE PROBLÈME, VEUILLEZ
CONTACTER NOTRE ÉQUIPE DU SERVICE CLIENT.**

SPEZIFIKATIONEN

PRODUKTBE SCHREIBUNG















Unsere Rattan-Kissen-Aufbewahrungsbox & Tasche ist darauf ausgelegt, strapazierfähige und wasserdichte Lagerung für Ihre Kissen während des Winters oder regnerischer Monate zu bieten.

Als Teil unserer Jardi Signature Collection passt diese Aufbewahrungsbox perfekt zu allen Kissen des Rattan-Ecksitzgruppen-Sets! Die super praktische Aufbewahrungstasche ist inklusive, um es Ihnen schnell und einfach zu machen, Ihre Kissen von Ihren Möbeln zur Aufbewahrung zu transportieren - keine umständliche Stapelung von Kissen mehr!

PRODUKTSPEZIFIKA

MAßE:	138 cm (H) x 68 cm (B) x 80 cm (T)
GEWICHT:	15kg
KAPAZITÄT:	720L

TEILELISTE

A		1PC	H	 M6*35	14PCS
B		1PC	I	 M6*30	2PCS
C		2PCS	J	 M6*20	8PCS
D		1PC	K		24PCS
E		1PC	L		1PC
F		2PCS	M		1PC
G		6PCS	N		2PCS

BENUTZERLEITFADEN

MONTAGEANLEITUNGEN

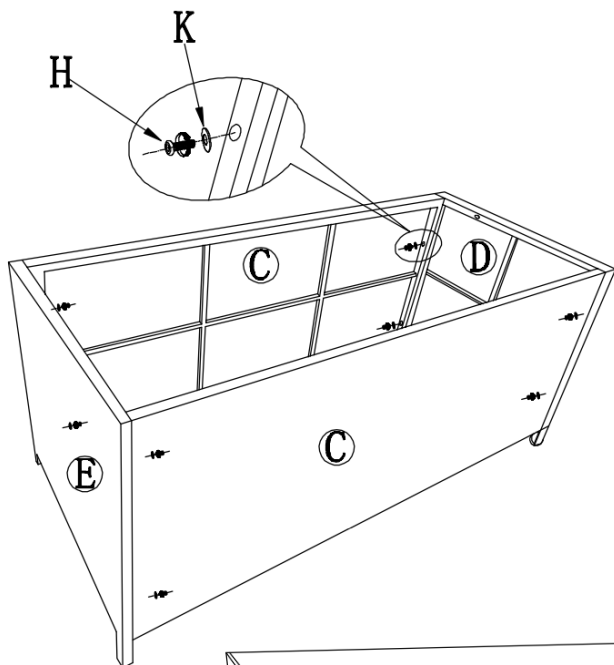

Beginnen Sie damit, die Box zusammenzuschrauben. Nehmen Sie die Teile (C), (E) und (D) und befestigen Sie diese gemäß dem Diagramm miteinander.

Verwenden Sie dazu die Schrauben (H) und die Unterlegscheiben (K). Jede Ecke hat 2 Löcher, in die die Schrauben eingesetzt werden.

Befestigen Sie als Nächstes das Teil (B) am Boden der nun erstellten Box. Verwenden Sie die gleichen Schrauben und Unterlegscheiben wie zuvor.

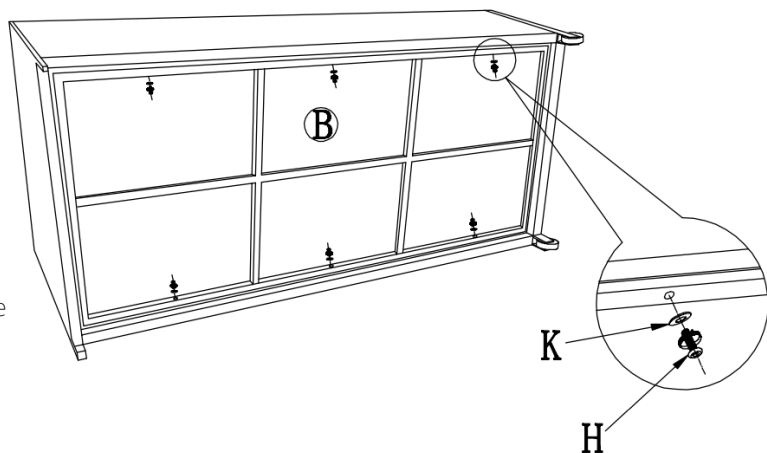

Die Haftung von Monster Group UK Limited ist auf den Handelswert des Produkts beschränkt.

BENUTZERLEITFADEN

MONTAGEANLEITUNGEN

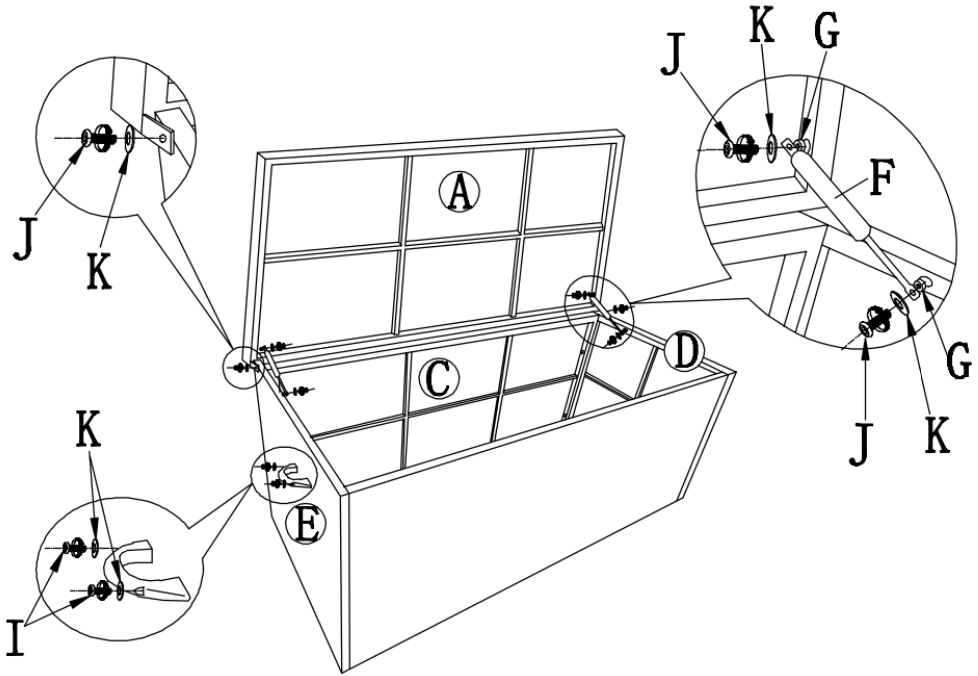

Um den Deckel der Box zu befestigen, nehmen Sie das Teil (A) und platzieren Sie es oben auf der Box. Mit geöffnetem Deckel schrauben Sie die Teile (F) und (G) gemäß dem Diagramm auf der Innenseite der Box fest, indem Sie die Schrauben (J) und die Unterlegscheiben (K) verwenden. Das Teil (G) kommt unter das Teil (F).

Schrauben Sie den Griff (M) an der Seite (E) der Box mit den Schrauben (I) und den Unterlegscheiben (K) fest.

WARTUNG

- Die Rattan-Aufbewahrungsbox sollte bei ungünstigen Wetterbedingungen wie starkem Regen und niedrigen Temperaturen im Innenbereich aufbewahrt werden.
- Stellen Sie sicher, dass die Kissen vor dem Verstauen im Beutel und in der Box vollständig trocken sind, um möglichen Schimmel- oder Mehltaubefall zu vermeiden.
- Überprüfen Sie regelmäßig Schrauben und Bolzen, um sicherzustellen, dass das Produkt seine Stabilität behält.

SICHERHEITSHINWEIS

SICHERES ARBEITEN

- Verwenden Sie dieses Produkt nicht für andere Zwecke als die vorgesehenen. Dieses Produkt ist nicht als Sitzgelegenheit konzipiert.
- Stellen Sie sicher, dass Sie die Bedienungsanleitung und die Sicherheitshinweise vollständig gelesen und verstanden haben, bevor Sie dieses Produkt verwenden.
- Wir empfehlen, dass mindestens zwei Personen gemeinsam die Montage durchführen.
- Halten Sie kleine Teile von Kindern fern.
- Stellen Sie sicher, dass dieses Produkt richtig montiert ist.
- Verwenden Sie dieses Produkt auf einer ebenen Fläche.
- Setzen Sie dieses Produkt keinem Feuer aus.
- Lassen Sie das Produkt nicht übermäßig heiß werden.

FEHLERBEHEBUNG

LÖSUNGSGUIDE

WAS MACHE ICH, WENN BEI MEINER BESTELLUNG TEILE FEHLEN?

Falls bei Ihrer Bestellung ein Teil zu fehlen scheint, wenden Sie sich bitte innerhalb von 7 Tagen nach Erhalt der Ware an unser freundliches und hilfsbereites Kundenservice-Team.

**FÜR ALLE ANDEREN FRAGEN WENDEN SIE SICH BITTE AN
UNSER KUNDENSERVICE-TEAM.**



ESPECIFICACIONES

DESCRIPCIÓN DEL PRODUCTO











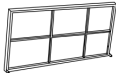



Nuestra bolsa y caja de almacenamiento de cojines de ratán están diseñadas para proporcionar un almacenamiento duradero e impermeable para tus cojines durante el invierno o meses lluviosos.

Como parte de nuestra Colección Signature Jardí, ¡esta caja de almacenamiento encajará perfectamente con todos los cojines del juego de esquina de ratán! ¡La bolsa de almacenamiento súper útil está incluida para que sea rápido y fácil de transportar tus cojines desde tus muebles al almacenamiento, ¡sin apilar incómodamente los cojines!

ESPECIFICACIONES DEL PRODUCTO

DIMENSIONES: 138 cm (Al) x 68 cm (An) x 80 cm (Prof)
PESO: 15kg
CAPACIDAD: 720L

LISTA DE PIEZAS

A		1PC	H	 M6*35	14PCS
B		1PC	I	 M6*30	2PCS
C		2PCS	J	 M6*20	8PCS
D		1PC	K		24PCS
E		1PC	L		1PC
F		2PCS	M		1PC
G		6PCS	N		2PCS

GUÍA DEL USUARIO

INSTRUCCIONES DE ENSAMBLAJE

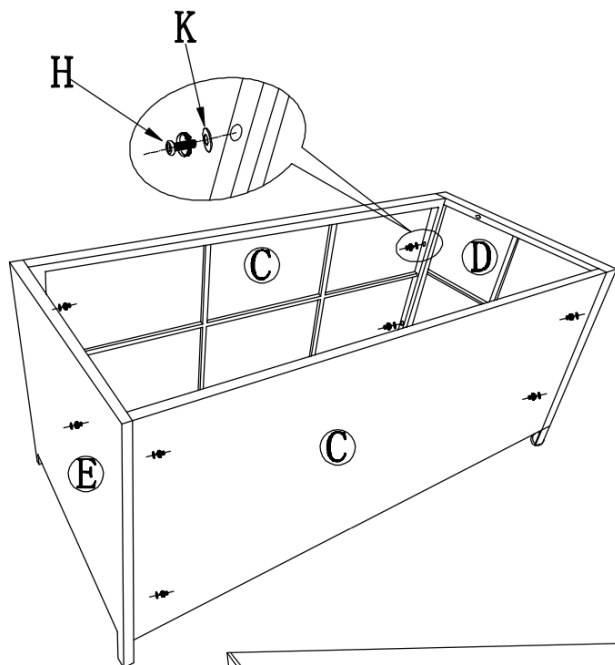

Comienza atornillando juntas la caja. Toma las piezas (C), (E) y (D) y ajústalas entre sí como se muestra en este diagrama.

Utiliza los tornillos (H) y las arandelas (K) para esto. Cada esquina tiene 2 agujeros para que los tornillos entren.

A continuación, une la pieza (B) a la parte inferior de la caja recién creada. Utiliza los mismos tornillos y arandelas que antes.

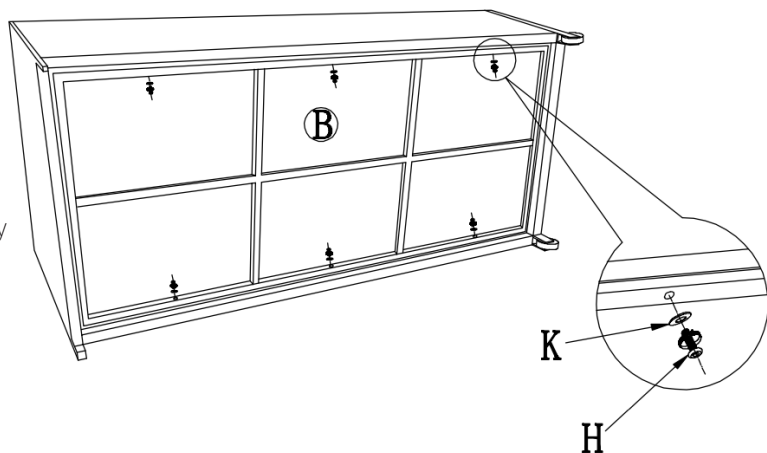

La responsabilidad de Monster Group UK Limited estará limitada únicamente al valor comercial del producto.

GUÍA DEL USUARIO

INSTRUCCIONES DE ENSAMBLAJE

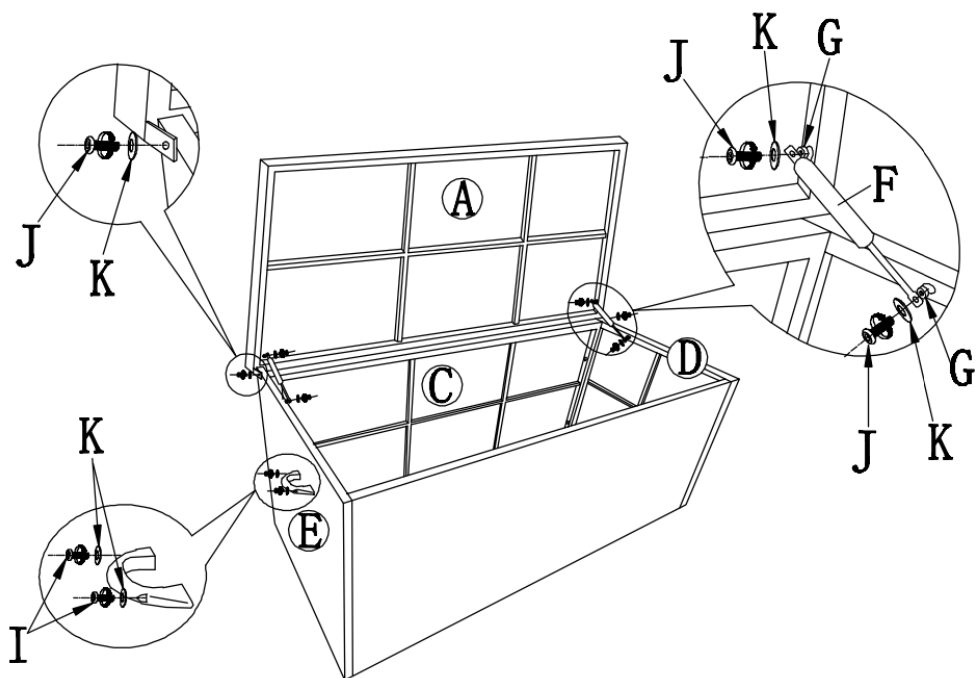

Para fijar la tapa de la caja, toma la pieza (A) y colócala en la parte superior de la caja. Con la tapa abierta, atornilla las piezas (F) y (G) en su lugar en el interior de la caja según el diagrama, utilizando los tornillos (J) y las arandelas (K). La pieza (G) va debajo de la pieza (F).

Atornilla el asa (M) en su lugar, utilizando los tornillos (I) y arandelas (K), en el lado (E) de la caja.

MANTENIMIENTO

- La caja de almacenamiento de ratán debe almacenarse en interiores para condiciones climáticas adversas, incluidas lluvias intensas y bajas temperaturas.
- Asegúrate de que los cojines estén completamente secos antes de guardarlos en la bolsa y la caja, para evitar posibles crecimientos de moho o humedad.
- Revisa regularmente los tornillos y pernos para asegurar que el producto mantenga su solidez.

CONSEJOS DE SEGURIDAD

! PRÁCTICAS DE TRABAJO SEGURAS

- No uses este producto para algo que no sea su propósito previsto. Este producto no está diseñado para ser utilizado como asiento.
- Asegúrate de haber leído y comprendido completamente el manual de instrucciones y los consejos de seguridad antes de usar este producto.
- Recomendamos que al menos dos personas trabajen juntas para el ensamblaje.
- Mantén las piezas pequeñas fuera del alcance de los niños.
- Asegúrate de que este producto esté instalado correctamente.
- Utiliza este producto en una superficie plana.
- No expongas este producto al fuego.
- No permitas que este producto se caliente excesivamente.

SOLUCIÓN DE PROBLEMAS

GUÍA DE RESOLUCIÓN

¿QUÉ PUEDO HACER SI LE FALTAN PIEZAS A MI PEDIDO?

Si parece faltar alguna pieza en su pedido, por favor, comuníquese con nuestro amable y servicial Equipo de Atención al Cliente en los 7 días posteriores a la recepción de su pedido.

**PARA CUALQUIER OTRO PROBLEMA, POR FAVOR CONTACTE
CON NUESTRO EQUIPO DE ATENCIÓN AL CLIENTE**

SPECIFICHE

DESCRIZIONE DEL PRODOTTO















La nostra cassa porta cuscini in rattan e borsa assicura un'archiviazione resistente e impermeabile per i cuscini durante l'inverno o i mesi piovosi.

Parte della Collezione Signature Jardi, si adatta perfettamente ai cuscini del Set Angolare in rattan. La borsa per l'archiviazione inclusa facilita il trasporto veloce e facile dai mobili all'archiviazione, eliminando gli scomodi impilamenti di cuscini!

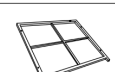
SPECIFICHE DEL PRODOTTO

DIMENSIONI: 138 cm (H) x 68 cm (L) x 80 cm (P)
PESO: 15kg
CAPACITÀ: 720L

LISTA COMPONENTI

A		1PC	H	 M6*35	14PCS
B		1PC	I	 M6*30	2PCS
C		2PCS	J	 M6*20	8PCS
D		1PC	K		24PCS
E		1PC	L		1PC
F		2PCS	M		1PC
G		6PCS	N		2PCS

GUIDA UTENTE

ISTRUZIONI PER IL MONTAGGIO

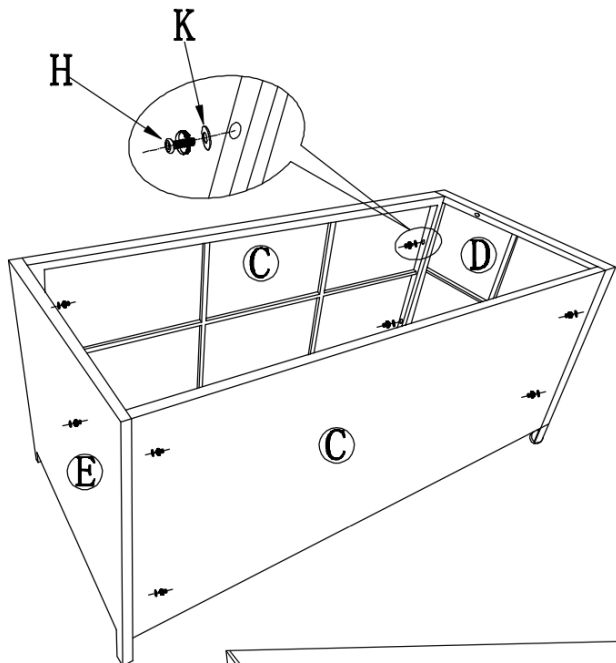

Inizia avvitando insieme la cassa. Unisci i pezzi (C), (E), e (D) come mostrato nel diagramma usando le viti (H) e le rondelle (K).

Ogni angolo presenta 2 fori per le viti.

Attacca successivamente il pezzo (B) sul fondo della cassa appena creata utilizzando le stesse viti e rondelle.

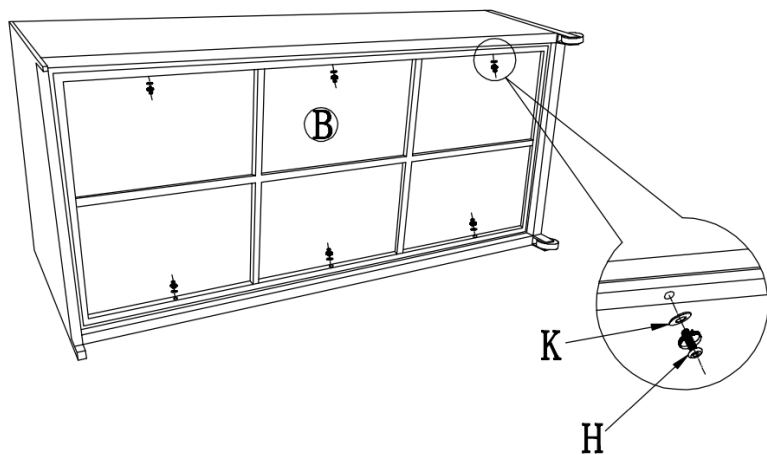

La responsabilità di Monster Group UK Limited sarà limitata al solo valore commerciale del prodotto.

GUIDA UTENTE

ISTRUZIONI PER IL MONTAGGIO

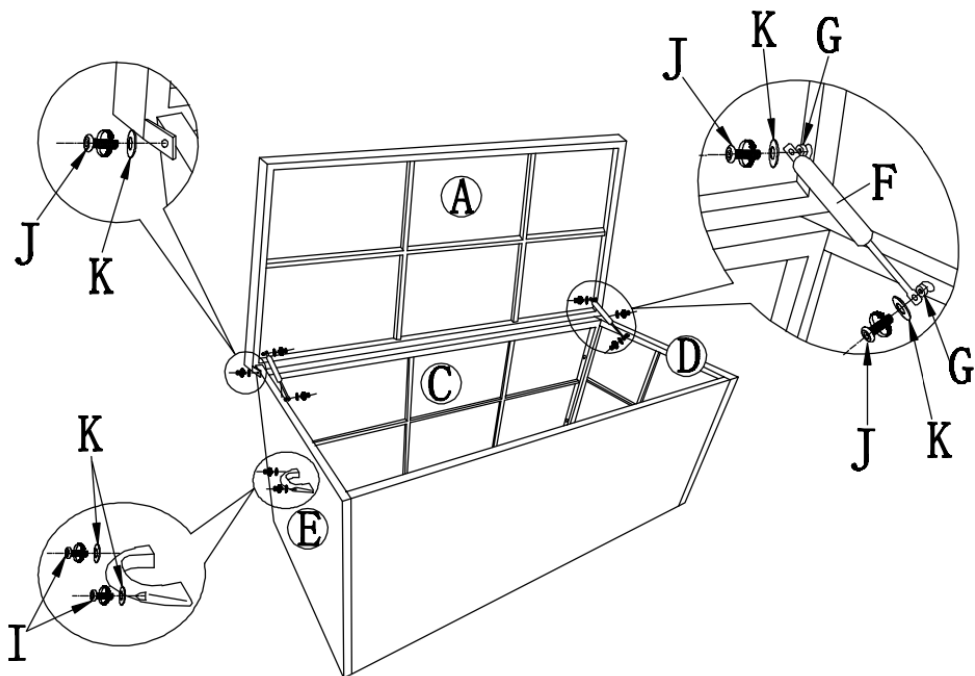

Per fissare il coperchio della cassa, posiziona il pezzo (A) sulla parte superiore e avvita i pezzi (F) e (G) all'interno utilizzando le viti (J) e le rondelle (K), seguendo il diagramma. Il pezzo (G) va sotto il pezzo (F).

Avvita la maniglia (M) sul lato (E) della cassa usando le viti (I) e le rondelle (K).

MANTENIMENTO

- Conserva la cassa porta cuscini in rattan al chiuso in condizioni meteorologiche avverse, inclusi forti piogge e basse temperature.
- Assicurati che i cuscini siano asciutti prima di riporli nella borsa e nella cassa per evitare formazioni di umido o muffa.
- Controlla regolarmente viti e bulloni per garantire la robustezza del prodotto.

CONSIGLI PER LA SICUREZZA

PRATICHE DI LAVORO SICURO

- Non utilizzare questo prodotto per scopi diversi da quelli previsti. Questo prodotto non è progettato per essere utilizzato come seduta.
- Assicurati di aver letto e compreso appieno il manuale di istruzioni e i consigli sulla sicurezza prima di utilizzare questo prodotto.
- Raccomandiamo che almeno due persone lavorino insieme per il montaggio.
- Mantieni le piccole parti lontane dai bambini.
- Assicurati che questo prodotto sia installato correttamente.
- Utilizza questo prodotto su una superficie piana.
- Non esporre questo prodotto al fuoco.
- Non permettere a questo prodotto di surriscaldarsi.

RISOLUZIONE DEI PROBLEMI

GUIDA ALLA RISOLUZIONE DEI PROBLEMI

COSA DEVO FARE SE NEL MIO ORDINE CI SONO DELLE PARTI MANCANTI?

Se sembra che all'interno del tuo ordine manchino delle parti, contatta il nostro gentile e disponibile team di assistenza clienti entro 7 giorni dalla ricezione del tuo ordine.

PER QUALUNQUE ALTRO PROBLEMA, CONTATTA IL NOSTRO TEAM DI ASSISTENZA CLIENTI.

OMSCHRIJVING

PRODUCT OMSCHRIJVING











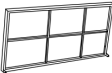



Onze Rattan Kussenopbergdoos & Tas is ontworpen om duurzame en waterdichte opslag te bieden voor uw kussens tijdens de winter of regenachtige maanden.

Als onderdeel van onze Jardi Signature Collection, past deze opbergdoos perfect bij alle kussens van de Rattan Hoekset! De superhandige opbergtas is inbegrepen om het snel en gemakkelijk te maken om uw kussens van uw meubels naar opslag te vervoeren - geen onhandig stapelen van kussens meer!

PRODUCTSPECIFICATIES

AFMETINGEN:	138 cm (H) x 68 cm (B) x 80 cm (D)
GEWICHT:	15kg
CAPACITEIT:	720L

ONDERDELENLIJST

A		1PC	H	 M6*35	14PCS
B		1PC	I	 M6*30	2PCS
C		2PCS	J	 M6*20	8PCS
D		1PC	K		24PCS
E		1PC	L		1PC
F		2PCS	M		1PC
G		6PCS	N		2PCS

HANDLEIDING

MONTAGE-INSTRUCTIES

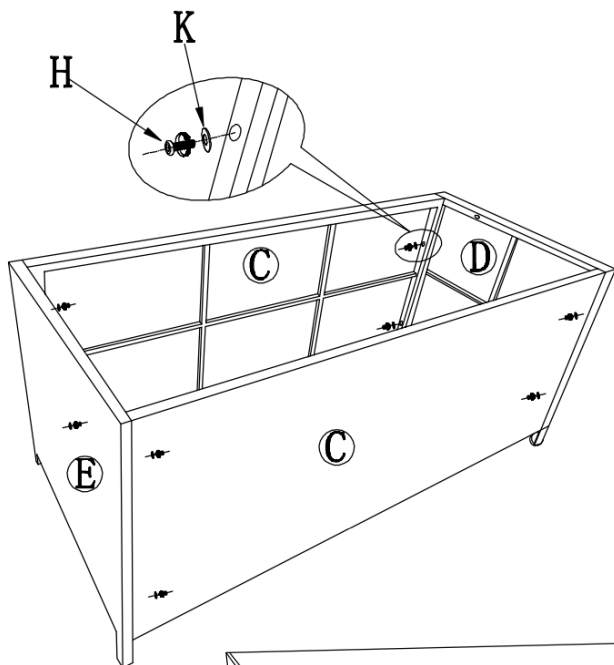

Begin met het in elkaar schroeven van de doos. Neem stukken (C), (E) en (D) en bevestig ze aan elkaar zoals getoond in dit diagram.

Gebruik hiervoor de (H) schroeven en de (K) ringen. Elke hoek heeft 2 gaten voor de schroeven om in te gaan.

Bevestig vervolgens het stuk (B) aan de onderkant van de nu gecreëerde doos. Gebruik dezelfde schroeven en ringen als voorheen.

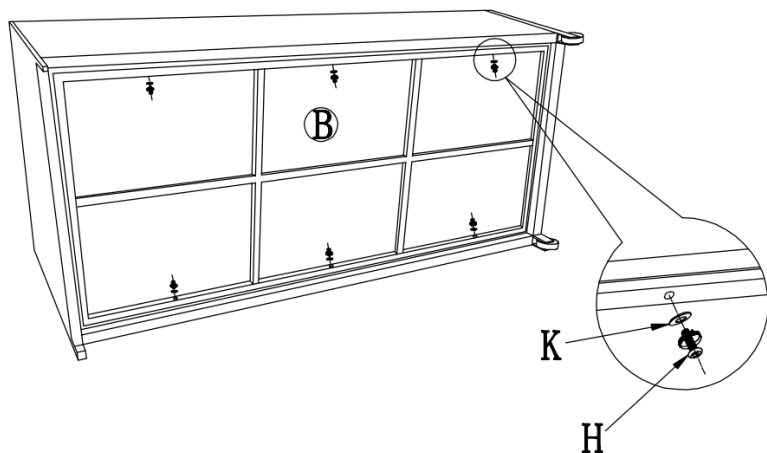

De aansprakelijkheid van Monster Group UK Limited is beperkt tot de commerciële waarde van het product.

HANDLEIDING

MONTAGE-INSTRUCTIES

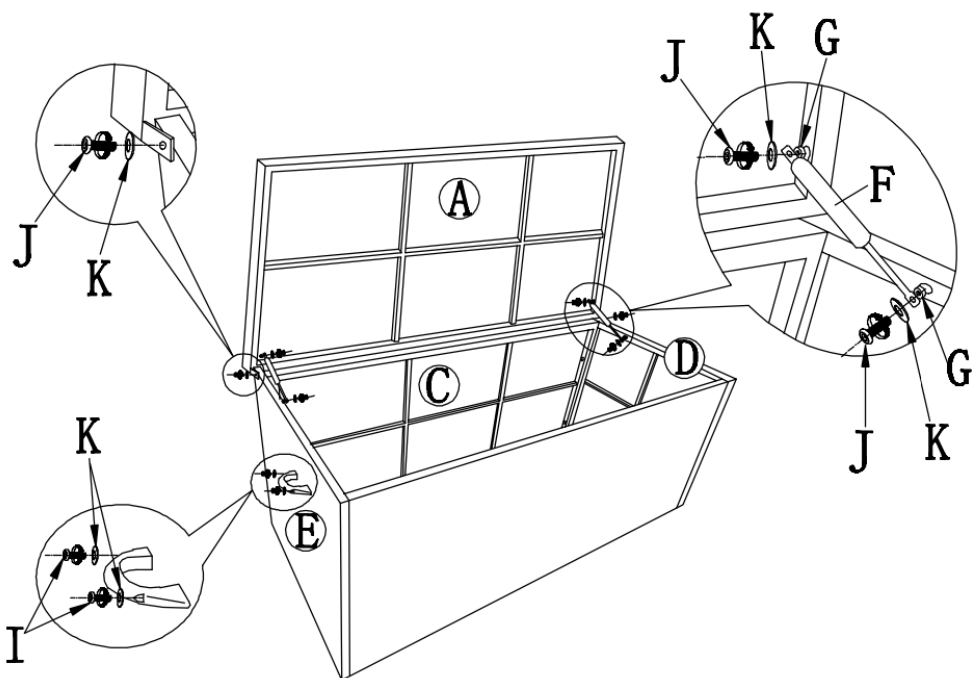

Om het deksel van de doos te bevestigen, neem stuk (A) en plaats het op de bovenkant van de doos. Met het deksel open, schroef stukken (F) en (G) aan de binnenkant van de doos volgens het diagram, door gebruik te maken van de (J) schroeven en (K) ringen. Stuk (G) gaat onder stuk (F).

Schroef de handgreep (M) op zijn plaats, door gebruik te maken van schroeven (I) en ringen (K), aan de zijde (E) van de doos.

ONDERHOUD

- De Rattan Opbergdoos moet binnenshuis worden bewaard bij ongunstige weersomstandigheden, inclusief zware regenval en lage temperaturen.
- Zorg ervoor dat kussens volledig droog zijn voordat ze in de tas en doos worden opgeborgen, om mogelijke schimmel- of meeldauwgroei te voorkomen.
- Controleer regelmatig schroeven en bouten om ervoor te zorgen dat het product zijn stevigheid behoudt.

VEILIGHEIDSADVIJES

VEILIG GEBRUIK

- Gebruik dit product niet voor andere doeleinden dan waarvoor het bedoeld is. Dit product is niet bedoeld om als zitplaats te worden gebruikt.
- Zorg ervoor dat u de instructiehandleiding en veiligheidstips volledig heeft gelezen en begrepen voordat u dit product gebruikt.
- Wij raden aan dat minstens twee personen samenwerken voor de montage.
- Houd kleine onderdelen uit de buurt van kinderen.
- Zorg ervoor dat dit product correct is gemonteerd.
- Gebruik dit product op een vlakke ondergrond.
- Stel dit product niet bloot aan vuur.
- Sta niet toe dat dit product buitensporig heet wordt.

PROBLEEM OPLOSSEN

OPLOSSINGEN

WAT MOET IK DOEN ALS ER ONDERDELEN VAN MIJN BESTELLING ONTBREKEN?

Neem wanneer een onderdeel van je bestelling ontbreekt binnen 7 dagen na ontvangst contact op met onze vriendelijke en behulpzame klantenservice.

**NEEM VOOR ALLE ANDERE KWESTIES CONTACT
MET ONZE KLANTENSERVICE OP.**



SPECIFIKATION

PRODUKTBeskrivning

Vår Rattan Kuddförvaringslåda & Väska är designad för att erbjuda hållbar och vattentät förvaring för dina sittdynor under vintern eller regniga månader.

Som en del av vår Jardi Signature Collection, kommer denna förvaringsbox passa perfekt för alla kuddar från Rattan Hörnsetet! Den superpraktiska förvaringsväskan ingår för att göra det snabbt och enkelt att transportera dina kuddar från dina möbler till förvaring - otympligt staplande av kuddar är ett minne blott!

PRODUKTSPECIFIKATIONER

MÅTT:	138 cm (H) x 68 cm (B) x 80 cm (D)
VIKT:	15kg
KAPACITET:	720 liter

MEDFÖLJANDE DELAR

A		1PC	H		14PCS
B		1PC	I		2PCS
C		2PCS	J		8PCS
D		1PC	K		24PCS
E		1PC	L		1PC
F		2PCS	M		1PC
G		6PCS	N		2PCS

ANVÄNDARGUIDE

MONTERINGS INSTRUKTIONER

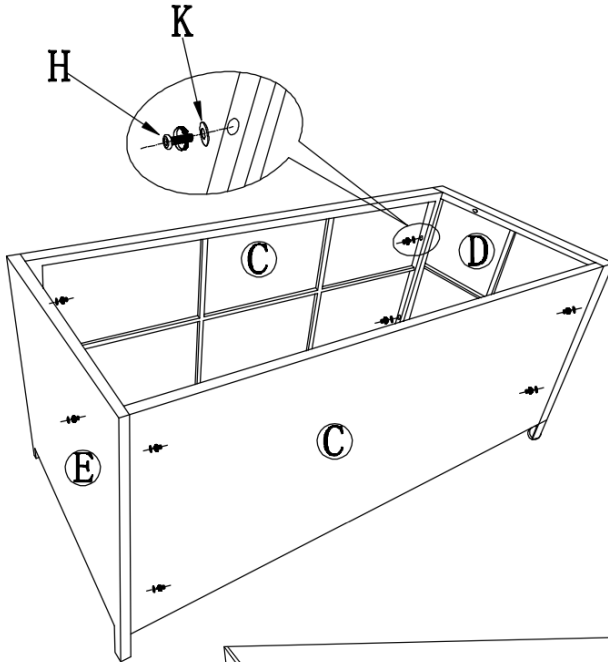

Börja med att skruva ihop boxen. Ta delarna (C), (E) och (D) och fäst dem i varandra enligt diagrammet.

Använd (H)-skruvarna och (K)-brickorna för detta. Varje hörn har 2 hål för skruvarna att gå in i.

Fäst sedan del (B) på botten av den nu monterade boxen. Använd samma skruvar och brickor som tidigare.

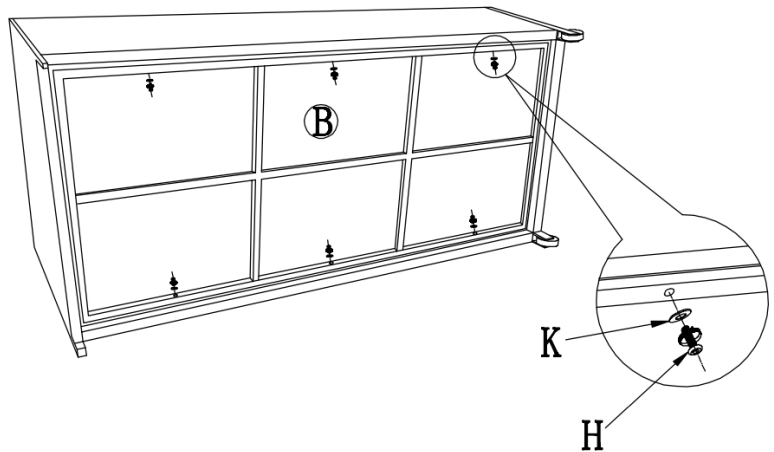

ANVÄNDARGUIDE

MONTERINGS INSTRUKTIONER

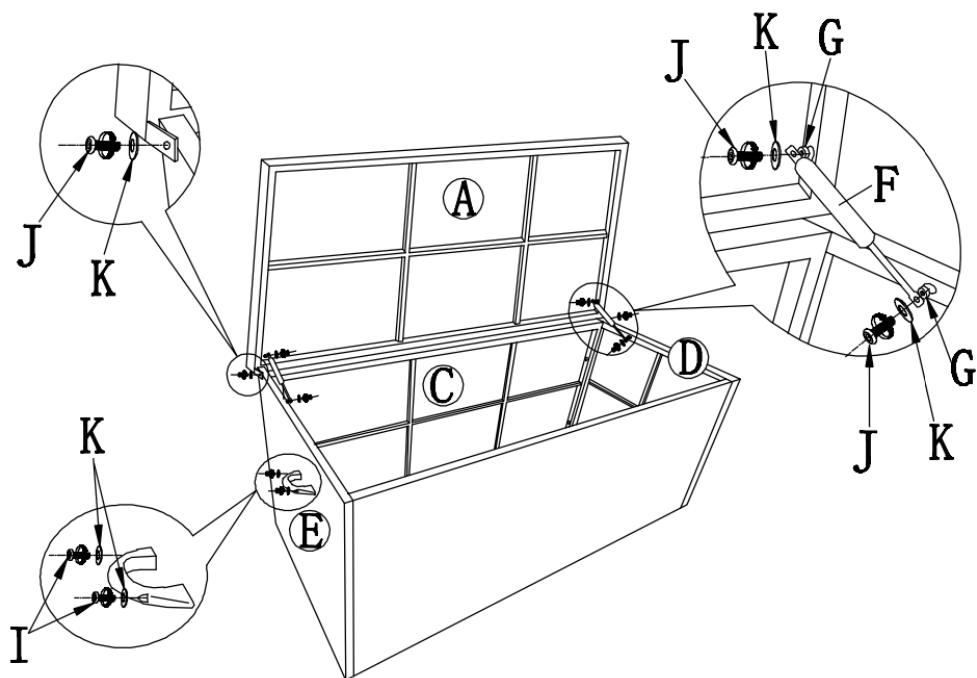

För att fästa boxlocket, ta del (A) och placera den ovanpå boxen. Med locket öppet, skruva fast delarna (F) och (G) på insidan av boxen enligt diagrammet, genom att använda (J)-skruvarna och (K)-brickorna. Del (G) går under del (F).

Skruva fast handtaget (M) på sidan (E) av boxen med skruvarna (I) och brickorna (K).

SKÖTSEL

- Rattan Förvaringsbox bör förvaras inomhus vid ogynnsamma väderförhållanden inklusive kraftigt regn och låga temperaturer.
- Se till att kuddarna är helt torra innan de förvaras i väskan och boxen för att undvika eventuell tillväxt av mögel.
- Kontrollera regelbundet skruvar och bultar för att säkerställa att produkten behåller sin stadighet.

SÄKERHETS RÅD

SÄKER ARBETSÖVNING

- Använd inte den här produkten för något annat än dess avsedda syften. Produkten är inte avsedd att användas som sittplats.
- Se till att du har läst och fullt förstått instruktionsboken och säkerhetsanvisningarna innan du använder produkten.
- Vi rekommenderar att minst två personer arbetar tillsammans vid monteringen.
- Håll små delar borta från barn.
- Se till att den här produkten är korrekt monterad.
- Använd den här produkten på en plan yta.
- Utsätt inte den här produkten för eld.
- Tillåt inte den här produkten att bli överdrivet varm.

FELSÖKNING

LÖSNINGSGUIDE

VAD GÖR JAG OM DET SAKNAS DELAR FRÅN MIN BESTÄLLNING?

Om det verkar som om någon del saknas i din beställning, kontakta vårt vänliga och hjälpsamma kundsupportteam inom 7 dagar efter mottagandet.

**FÖR ALLA ANDRA FRÅGOR, VÄNLIGEN KONTAKTA VÅRT
KUNDSUPPORTTEAM.**

Monster Group (UK) is one of the UK's fastest growing online retailers. We supply a diverse range of products which offer exceptional value for money. We strive to provide the best possible customer experience with free UK delivery across all our products and a Monster Guarantee for 100% satisfaction.

For information regarding this device or other products from our Monster divisions please contact Sales.

SALES

TEL: 01347 878 888
EMAIL: hello@monstershop.co.uk

For queries about this device, warranty, returns or reporting faults please contact Support.

SUPPORT

TEL: 01347 878 887
EMAIL: help@monstershop.co.uk

Pour plus d'informations concernant cet appareil ou d'autres produits de nos divisions de Monster veuillez utiliser les détails suivants ci-dessous.

DÉPARTEMENT COMMERCIAL

TEL: 01347 878 888
EMAIL: bonjour@monstershop.eu

Pour les interrogations concernant cet appareil, la garantie, les retours ou les défauts de déclaration veuillez utiliser les détails suivants ci-dessous.

DÉPARTEMENT DE SOUTIEN

TEL: 01347 878 887
EMAIL: help@monstershop.co.uk

Para información sobre este dispositivo u otros productos de nuestras divisiones de Monster por favor use los siguientes detalles.

DEPARTAMENTO DE VENTAS

TEL: 01347 878 888
EMAIL: hola@monstershop.eu

Para consultas sobre este dispositivo, la garantía, devoluciones o denuncias de fallos por favor use los siguientes detalles.

DEPARTAMENTO DE SOPORTE

TEL: 01347 878 887
EMAIL: help@monstershop.co.uk

Für Informationen bezüglich dieses Geräts oder anderer Produkte aus unserer Monster-Abteilung, benutzen sie die folgenden unten aufgeführten Angaben.

VERKAUFSABTEILUNG

TEL: 01347 878 888
EMAIL: hallo@monstershop.eu

Für Fragen über dieses Gerät, die Garantie, Rückgaben oder bei Störungen, benutzen sie die folgenden unten aufgeführten Angaben.

SUPPORT-ABTEILUNG

TEL: 01347 878 887
EMAIL: help@monstershop.co.uk

Per informazioni riguardanti questo dispositivo o altri prodotti dalle categorie Monster utilizzare i dettagli sotto riportati.

DIPARTIMENTO VENDITE

TEL: 01347 878 888
EMAIL: ciao@monstershop.eu

Per domande riguardo dispositivo, garanzia, reso o per riferire di guasti, utilizzare i dettagli sotto riportati.

DIPARTIMENTO SUPPORTO

TEL: 01347 878 887
EMAIL: help@monstershop.co.uk

Voor informatie over dit apparaat of andere producten van onze Monster-divisies kunt u contact opnemen met onze verkoop afdeling. Signifieer details.

VERKOOP

TEL: 01347 878 888
EMAIL: hello@monstershop.co.uk

Voor vragen over dit apparaat, garantie, retourzendingen of het melden van fouten kunt u contact opnemen met de klanten support details.

SUPPORT

TEL: 01347 878 887
EMAIL: help@monstershop.co.uk

För information om denna enhet eller andra produkter från våra Monster-divisioner vänligen kontakta vårt hjälpsamma säljteam. Önska verköpsafdelning. Signifieer details.

SALES

TEL: 01347 878 888
EMAIL: hello@monstershop.co.uk

Kontakta vår kundsupport för frågor om denna enhet, garanti, retur eller felrapportering.

SUPPORT

TEL: 01347 878 887
EMAIL: help@monstershop.co.uk

Monster House, Alan Farnaby Way,
Sheriff Hutton Industrial Estate,
Sheriff Hutton, York, YO60 6PG
www.monstershop.co.uk



 Try **Monster. Buy Monster. Be Monster.** 