



# DOUBLE / TRIPLE WHEELIE BIN STORAGE

24409 / 24410

INSTRUCTION MANUAL

[www.monstershop.co.uk](http://www.monstershop.co.uk)

# CONTENTS

## ENGLISH

PRODUCT DESCRIPTION	04
PRODUCT SPECIFICS	04
ITEM CONTENTS	05-09
SAFE WORKING PRACTICE	09
ASSEMBLY INSTRUCTIONS	10-14
TROUBLESHOOTING	15

## FRANÇAIS

DESCRIPTION DU PRODUIT	16
SPÉCIFICATIONS DU PRODUIT	16
CONTENU DE L'ARTICLE	17-21
BONNES PRATIQUES DE TRAVAIL	21
INSTRUCTIONS DE MONTAGE	22-26
DÉPANNAGE	27

## DEUTSCHE

PRODUKTBESCHREIBUNG	28
PRODUKTMERKMALE	28
LIEFERUMFANG	29-33
SICHERE ARBEITSPRAXIS	33
MONTAGEANLEITUNGEN	34-38
FEHLERBEHEBUNG	39

# CONTENTS

## ESPAÑOL

DESCRIPCIÓN DEL PRODUCTO	40
ESPECIFICACIONES DEL PRODUCTO	40
CONTENIDO DEL ARTÍCULO	41-45
PRÁCTICAS DE TRABAJO SEGURAS	45
INSTRUCCIONES DE MONTAJE	46-50
SOLUCIÓN DE PROBLEMAS	51

## ITALIANO

DESCRIZIONE DEL PRODOTTO	52
SPECIFICHE DEL PRODOTTO	52
CONTENUTO DELL'PRODOTTO	53-57
PRATICA DI LAVORO SICURA	57
ISTRUZIONI DI MONTAGGIO	58-62
RISOLUZIONE DEI PROBLEMI	63

CONTACT US	64
------------	----



# SPECIFICATION

## PRODUCT DESCRIPTION

Thank you for purchasing this Wheelie Bin Storage shed. You are looking out from your window. Your garden is looking splendid. All the time and hard work seems worth it. But the view is hindered, spoiled by unsightly, ugly bins. It's a problem we at Monster Group UK have ourselves, until now!

The Wheelie Bin Storage shed perfectly conceals two or three (depending on your order) 240L UK Standard Wheelie Bins and helps you reclaim your garden! With a quick and easy assemble, lifting lids attached to your bin lids, and treated, ethically-sourced timber that is long-lasting with a great-looking finish, you can feel relieved that you won't have to suffer with those unpleasant views again. We just know you'll love it!

**WARNING: The assembly of this product requires two persons. Do not attempt to undertake assembly alone.**

Please refer to and read the Safe Working Practice to ensure prevention of injury or damage to the device before starting.

## PRODUCT SPECIFICS





	DOUBLE STORAGE	TRIPLE STORAGE
<b>DIMENSION (H x W x D):</b>	122 x 149 x 92cm	120 x 198 x 81cm
<b>WEIGHT:</b>	25.5KG	31.5KG
<b>MATERIAL:</b>	Fir	Fir

Monster Group UK Limited's liability will be limited to the commercial value of the product only.

# SPECIFICATION

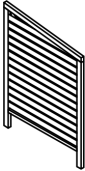
## ITEM CONTENTS

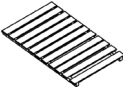
### DOUBLE STORAGE

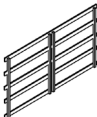



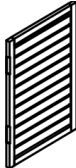
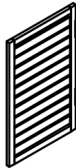

PART NO.	PART NAME	QUANTITY	DIAGRAM
1	Right Side Panel	1	
2	Centre Panel	1	
3	Left Side Panel	1	
4	Lid Panel	1	
5	Lid Panel	1	
6	Back Panel	1	

# SPECIFICATION

## ITEM CONTENTS

### DOUBLE STORAGE



PART NO.	PART NAME	QUANTITY	DIAGRAM
7	Base Plate	2	
8	Left Door	1	
9	Right Door	1	

PART NO.	PART NAME	QUANTITY	DIAGRAM
A	Screw	26	 $\phi 3 \times 16\text{mm}$
B	Screw	12	 $\phi 3.5 \times 20\text{mm}$
C	Screw	8	 $\phi 3.5 \times 35\text{mm}$
D	Screw	18	 $\phi 3.5 \times 25\text{mm}$
E	Lock Bracket	2	
F	Wall Bracket	2	

# SPECIFICATION

## ITEM CONTENTS

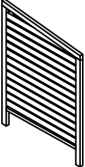

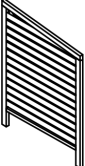
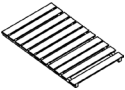
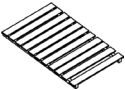
### TRIPLE STORAGE

PART NO.	PART NAME	QUANTITY	DIAGRAM
1	Right Side Panel	1	
2	Centre Panel	1	
3	Centre Panel	1	
4	Left Side Panel	1	
5	Lid Panel	1	
6	Lid Panel	1	

# SPECIFICATION

## ITEM CONTENTS

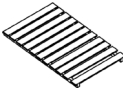
### TRIPLE STORAGE

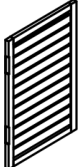
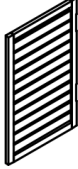
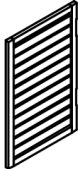





PART NO.	PART NAME	QUANTITY	DIAGRAM
7	Lid Panel	1	
8	Back Panel	1	
9	Base Plate	3	
10	Left Door	1	
11	Centre Door	1	
12	Right Door	1	



# SPECIFICATION

## ITEM CONTENTS

### TRIPLE STORAGE

PART NO.	PART NAME	QUANTITY	DIAGRAM
A	Screw	39	 $\phi 3*16\text{mm}$
B	Screw	16	 $\phi 3.5*20\text{mm}$
C	Screw	12	 $\phi 3.5*35\text{mm}$
D	Screw	24	 $\phi 3.5*25\text{mm}$
E	Lock Bracket	3	
F	Wall Bracket	2	

# SAFETY ADVICE

## SAFE WORKING PRACTICE

Please read through the Safe Working Practice to ensure prevention of injury or damage to the device.

The assembly instructions set out in this manual should be strictly adhered to and carefully followed.

You should always work alongside another when assembling and lifting this item. Never attempt to lift the item unaided.

You should not attempt to modify or change the assembly or design of this item.

# USER GUIDE

## ASSEMBLY INSTRUCTIONS

### DOUBLE WHEELIE BIN STORAGE

1. Align the Right Side Panel (1), Left Side Panel (3) and Centre Panel (2) as in Image 1.
2. Use the Back Panel (6) to connect all three panels and use 6 x D Screws per panel to attach.
3. If you look carefully at Image 6, you will notice the Back Panel (6) has five arms on either side. The screws must be attached by the top, bottom, and middle arm.

**Please Note: Check that you have used 18 x D Screws in total, as in Image 1.**

4. Now that the three main panels are connected from the back, use 2 x Base Plates (7) and place them between each panel at the front.
5. Align and use 4 x B Screws per Base Plate. Use 8 x B Screws in total for this section. See Image 2 to check your progress.

IMAGE 1

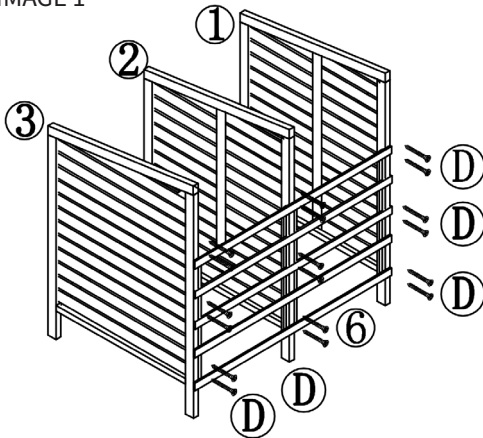
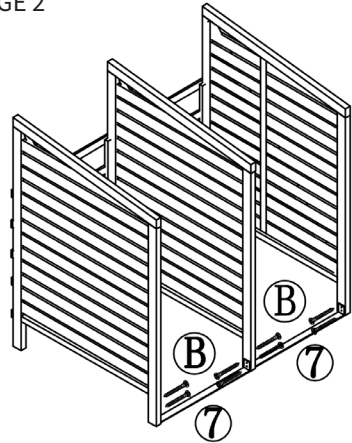

IMAGE 2



6. Place the first Lid Panel (4) on top of the Right Side Panel (1) and Centre Panel (2). Using 4 x C Screws, tighten into place.
7. Look at Image 3. The lid is attached at the back of the storage shed. See Image 3A. This is where you need to place the screws. Repeat this process for the next Lid Panel (5).
8. When attaching the doors, note that the hinges sit inside the Centre Panel (2) and the doors swing outwards from the Centre Panel.
9. Align the Right Door (9) and use 6 x A Screws to attach. Repeat to attach the Left Door (8), remembering to attach the hinge from within the Centre Panel (2). See Image 4 for reference.

# USER GUIDE

## ASSEMBLY INSTRUCTIONS

### DOUBLE WHEELIE BIN STORAGE

Please Note: If necessary, you can attach the Wheelie Bin Storage to another surface to ensure it remains sturdy and in place. To do so, use 4 x B Screws to attach the Wall Brackets to the structure, then use 4 x B Screws to attach to another surface.

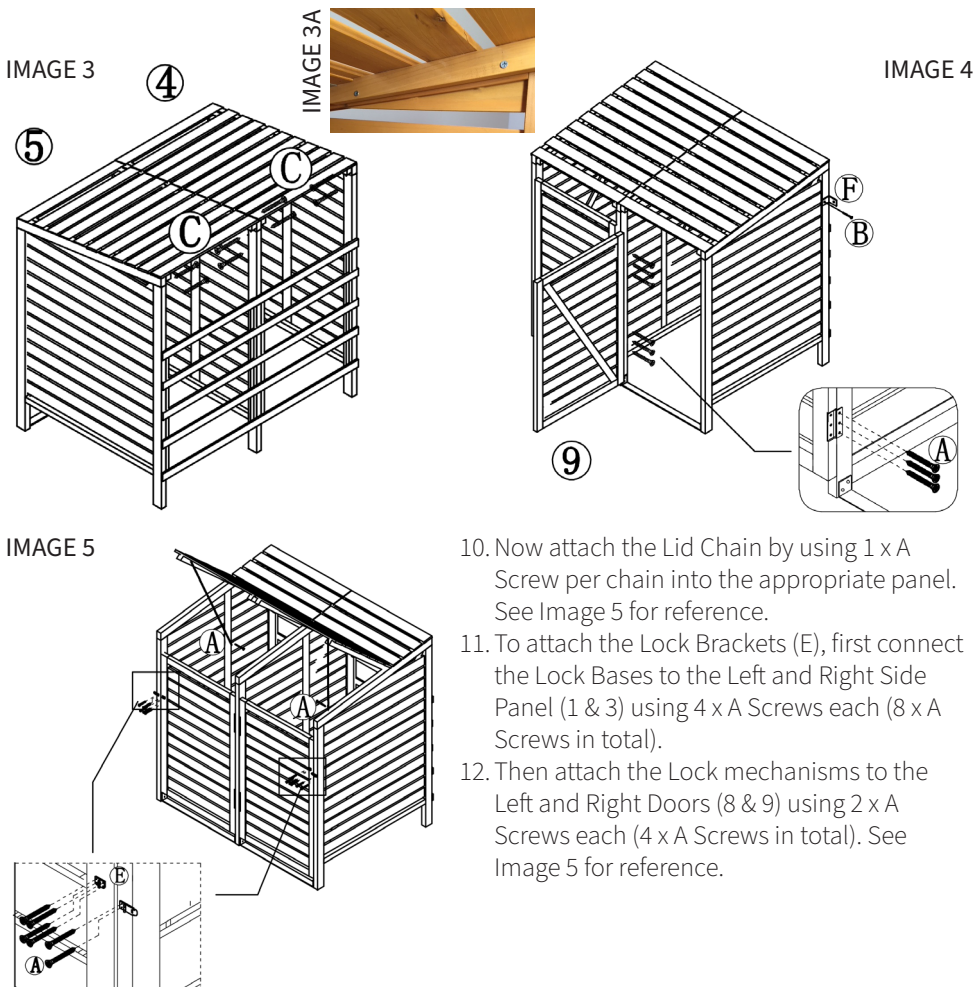

# USER GUIDE

## ASSEMBLY INSTRUCTIONS

### TRIPLE WHEELIE BIN STORAGE

1. Align the Right Side Panel (1), Left Side Panel (4) and both Centre Panels (2 & 3) as in Image 6.
2. Use the Back Panel (8) to connect all four panels and use 6 x D Screws per panel to attach.
3. If you look carefully at Image 6, you will notice the Back Panel (8) has five arms on either side. The screws must be attached by the top, bottom, and middle arm.

**Please Note: Check that you have used 24 x D Screws in total, as in Image 6.**

4. Now that the four main panels are connected at the back, use the 3 x Base Plates (9) and place them between each panel at the front.
5. Align and use 4 x B Screws per Base Plate. Use 12 x B Screws in total for this section. See Image 7 to check your progress.

IMAGE 6

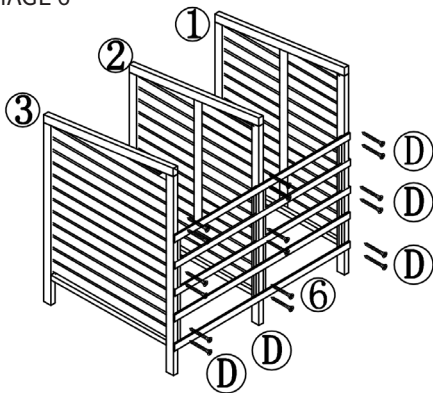
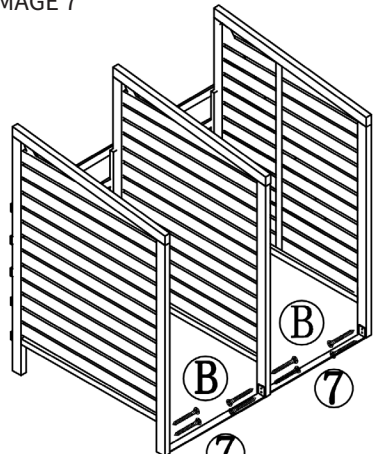

IMAGE 7



6. Now connect the Lid Panels (5, 6, & 7). Place the first Lid Panel on top of the Right Side Panel (1) and the first Centre Panel (2).
7. Using 4 x C Screws, screw into place. Look at Image 8. The lid is attached at the back of the storage shed. See Image 8A. This is where you need to place the screws.
8. Repeat this process for the remaining Lid Panels.

# USER GUIDE

## ASSEMBLY INSTRUCTIONS

### TRIPLE WHEELIE BIN STORAGE

IMAGE 8

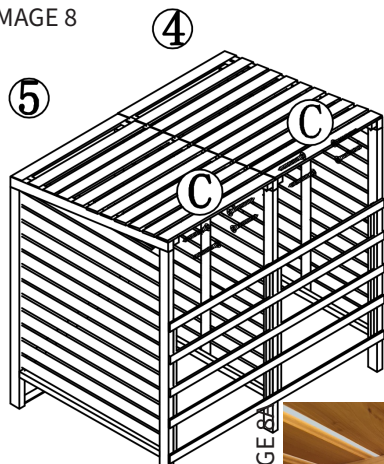

IMAGE 9

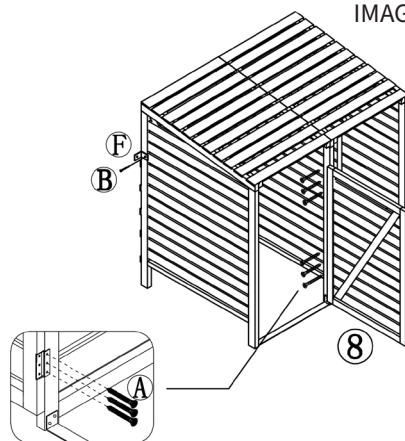

IMAGE 8



9. When attaching the doors, note that the doors swing outwards from the Centre Panels (2 & 3).
10. Align the Right Door (12) and use 6 x A Screws to attach. Repeat to attach the Left Door (10) and Centre Door (11), remembering to attach the hinge from within the Centre Panels (3 & 4). See Image 4 for reference.

**Please Note:** If necessary, you can attach the Wheelie Bin Storage to another surface to ensure it remains sturdy and in place. To do so, use 4 x B Screws to attach the Wall Brackets to the structure, then use 4 x B Screws to attach to another surface.

# USER GUIDE

## ASSEMBLY INSTRUCTIONS

### TRIPLE WHEELIE BIN STORAGE

11. Now attach the Lid Chain by using 1 x A Screw per chain into the appropriate panel. See Image 10.
12. To attach the Lock Brackets (E), first connect the Lock Bases to the panel left of the Left Door (10) and Centre Door (11), and to the panel right of the Right Door (12) using 4 x A Screws each (12 x A Screws in total). Check with Image 10 for accuracy.
13. Attach the Lock mechanisms directly on all three doors (10, 11, 12) using 2 x A Screws each. (6 x A Screws in total). See Image 10 for reference.

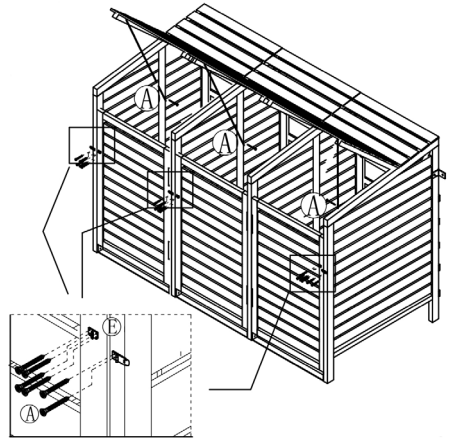

# TROUBLESHOOTING

## RESOLUTION GUIDE

### WHAT DO I DO IF THERE ARE MISSING PARTS FROM MY ORDER?

If there appears to be any part missing from your order, contact our friendly and helpful Customer Support Team within 7 days of receipt.

### WHAT DO I DO IF MY BIN STORAGE UNIT IS ASKEW OR SHAKY?

The design of the Storage Bins means that it should be solid and square. If it isn't, it's likely it hasn't quite been assembled right. Return to the Assembly Instructions and follow them carefully. Tighten screws as much as possible, and ensure you are assembling with at least 1 other person.

### WHAT DO I DO IF THE PARTS DO NOT GO TOGETHER WELL?

Check that you have followed the instructions accurately. It is generally considered best practice to ensure the panels go together and are flush before screwing into place. This can also enhance rigidity.

### WHAT DO I DO IF I WANT TO PUT MY BIN STORAGE UNIT OUTDOORS?

The material of this Bin Storage is treated FSC timber, meaning it's suitable for outdoor use and will cope well with rain, wind, and other conditions.

**FOR ALL OTHER ISSUES, PLEASE CONTACT OUR  
CUSTOMER SUPPORT TEAM.**

# SPÉCIFICATIONS

## DESCRIPTION DU PRODUIT

Merci d'avoir acheté ce hangar de stockage à roulettes. Vous regardez à travers votre fenêtre. Votre jardin est magnifique. Tout le temps et le dur travail en vaut la peine. Mais la vue est entravée, gâchée par des poubelles moches et laides. C'est un problème auquel nous avons fait face chez Monster Group UK!

Le hangar de stockage à roulettes dissimule parfaitement deux ou trois (selon votre commande) hangars de stockage à roulettes standards de 240L RU et vous aide à garder votre jardin clair! Avec un montage rapide et facile, des couvercles de levage attachés à vos couvercles de poubelle, et du bois traité, d'origine éthique qui est durable avec une belle finition, vous pouvez vous sentir soulagé que vous n'aurez pas à souffrir de ces vues désagréables encore. Nous savons par coeur que vous l'aimerez!

**Avertissement: L'assemblage de ce produit nécessite deux personnes. N'essayez pas de l'assembler seul.**

**Veillez consulter et lire les conseils de sécurité, Pratiques de travail sécuritaires pour assurer la prévention des blessures ou des dommages au produit avant de commencer.**

## SPÉCIFICATIONS DU PRODUIT

	DOUBLE RANGEMENT	TRIPLE RANGEMENT
<b>DIMENSION (H x W x D):</b>	122 x 149 x 92cm	120 x 198 x 81cm
<b>POIDS:</b>	25.5KG	31.5KG
<b>MATÉRIEL:</b>	Sapin	Sapin





La responsabilité de Monster Group UK Limited sera limitée à la valeur commerciale du produit.

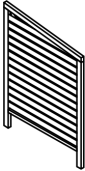

# SPÉCIFICATIONS

## CONTENU DE L'ARTICLE

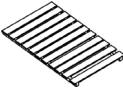

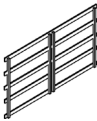
### DOUBLE RANGEMENT





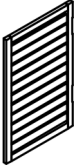

PART NO.	PART NAME	QUANTITY	DIAGRAM
1	Panneau Latéral Droit	1	
2	Panneau Central	1	
3	Panneau Latéral Gauche	1	
4	Panneau de Couvercle	1	
5	Panneau de Couvercle	1	
6	Panneau Arrière	1	

# SPÉCIFICATIONS

## CONTENU DE L'ARTICLE

### DOUBLE RANGEMENT



PART NO.	PART NAME	QUANTITY	DIAGRAM
7	Plaque de Base	2	
8	Porte Gauche	1	
9	Porte Droite	1	

PART NO.	PART NAME	QUANTITY	DIAGRAM
A	Vis	26	 $\phi 3*16\text{mm}$
B	Vis	12	 $\phi 3.5*20\text{mm}$
C	Vis	8	 $\phi 3.5*35\text{mm}$
D	Vis	18	 $\phi 3.5*25\text{mm}$
E	Support de Verrouillage	2	
F	Support Mural	2	

# SPÉCIFICATIONS

## CONTENU DE L'ARTICLE

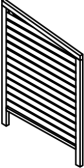

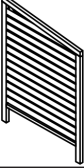
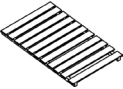
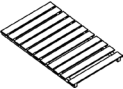
### TRIPLE RANGEMENT

PART NO.	PART NAME	QUANTITY	DIAGRAM
1	Panneau Latéral Droit	1	
2	Panneau Central	1	
3	Panneau Central	1	
4	Panneau Latéral Gauche	1	
5	Panneau de Couvercle	1	
6	Panneau de Couvercle	1	

# SPÉCIFICATIONS

## CONTENU DE L'ARTICLE



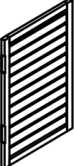
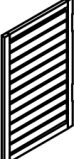
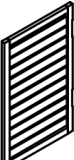



### TRIPLE RANGEMENT

PART NO.	PART NAME	QUANTITY	DIAGRAM
7	Panneau de Couvercle	1	
8	Panneau Arrière	1	
9	Plaque de Base	3	
10	Porte Gauche	1	
11	Porte Centrale	1	
12	Porte Droite	1	

# SPÉCIFICATIONS

## CONTENU DE L'ARTICLE

### TRIPLE RANGEMENT

PART NO.	PART NAME	QUANTITY	DIAGRAM
A	Vis	39	 $\phi 3*16\text{mm}$
B	Vis	16	 $\phi 3.5*20\text{mm}$
C	Vis	12	 $\phi 3.5*35\text{mm}$
D	Vis	24	 $\phi 3.5*25\text{mm}$
E	Support de Verrouillage	3	
F	Support Mural	2	

# CONSEILS DE SECURITÉ

## BONNES PRATIQUES DE TRAVAIL

Veuillez consulter et lire les Mesures de sécurité de manutention afin d'éviter toute blessure ou tout dommage à l'outil.

Les instructions d'assemblage dans cet manuel devrait être strictement adhérer et suivie prudemment.

Vous devriez toujours travailler avec la présence de quelqu'un lors de l'assemblage et soulevement de ce produit. Ne tenter jamais de le soulever ce produit sans aide.

Ne tenter pas de modifier ou changer l'assemblage ou le design de ce produit.

# GUIDE D'UTILISATION

## INSTRUCTIONS DE MONTAGE

### DOUBLE POUBELLE À ROULETTE

1. Alignez le panneau latéral droit (1), le panneau latéral gauche (3) et le panneau central (2) comme sur l'image 1.
2. Utilisez le panneau arrière (6) pour connecter les trois panneaux et utilisez 6 vis D par panneau à attacher.
3. Si vous regardez attentivement l'image 6, vous remarquerez que le panneau arrière (6) a cinq bras de chaque côté. Les vis doivent être fixées par le haut, le bas et le bras central.

**Remarque: Vérifiez que vous avez utilisé des vis 18 x D au total, comme dans Image 1.**

4. Maintenant que les trois panneaux principaux sont connectés à l'arrière, utilisez 2 plaques de base (7) et placez-les entre chaque panneau à l'avant.
5. Alignez et utilisez 4 vis B par plaque de base. Utilisez 8 vis B au total pour cette section. Voir l'image 2 pour vérifier vos progrès.

IMAGE 1

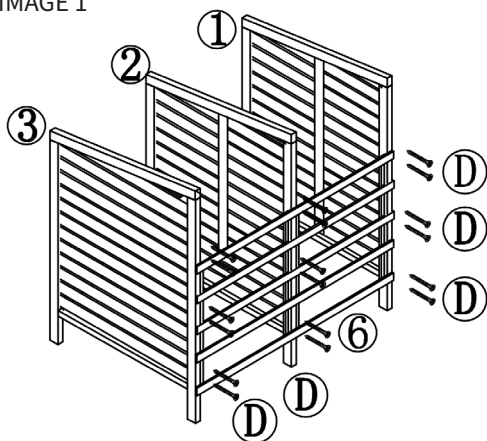
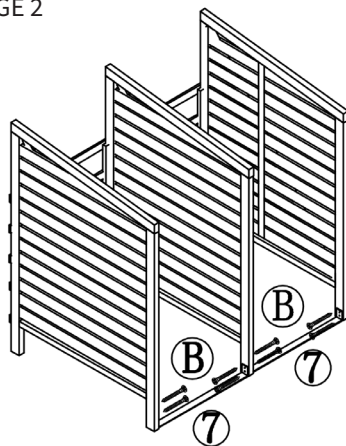

IMAGE 2



6. Placez le premier panneau de couvercle (4) sur le panneau latéral droit (1) et le panneau central (2). À l'aide de 4 vis C, serrez en place.
7. Regardez l'image 3. Le couvercle est attaché à l'arrière du hangar de stockage. Voir l'image 3A. C'est ici que vous devez placer les vis. Répétez ce processus pour le panneau de couvercle suivant (5).
8. Lorsque vous fixez les portes, notez que les charnières sont placées à l'intérieur du panneau central (2) et que les portes pivotent vers l'extérieur du panneau central. Alignez la Porte Droite (9) et utilisez 6 Vis A pour attacher.
9. Répétez l'opération pour fixer la porte gauche (8) en vous rappelant de fixer la charnière à l'intérieur du panneau central (2). Voir Image 4 pour référence.

# GUIDE D'UTILISATION

## INSTRUCTIONS DE MONTAGE

### DOUBLE POUBELLE À ROULETTE

Remarque: S'il est nécessaire, vous pouvez fixer le meuble à roulettes sur une autre surface pour vous assurer qu'il reste solide et en place. Pour ce faire, utilisez des vis 4 x B pour fixer les supports muraux à la structure, puis utilisez des vis 4 x B pour les fixer à une autre surface.

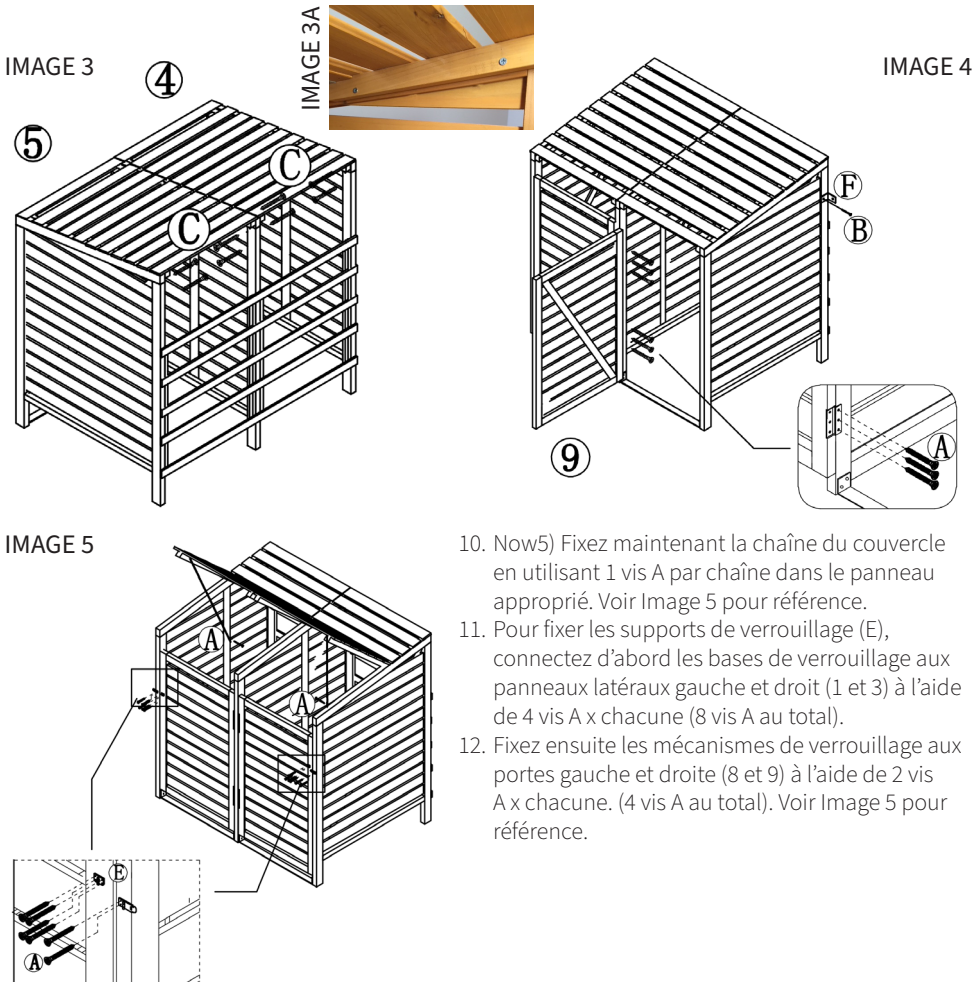

# GUIDE D'UTILISATION

## INSTRUCTIONS DE MONTAGE

### TRIPLE POUBELLE À ROULETTE

1. Alignez le panneau latéral droit (1), le panneau latéral gauche (4) et les deux panneaux centraux (2 et 3) comme sur l'image 6.
2. Utilisez le panneau arrière (8) pour connecter les quatre panneaux et utilisez 6 vis D panneau à attacher.
3. Si vous regardez attentivement l'image 6, vous remarquerez que le panneau arrière (8) a cinq bras de chaque côté. Les vis doivent être fixées par le haut, le bas et le bras central.

**Remarque: Vérifiez que vous avez utilisé 24 vis au total, comme dans l'image 6.**

4. Maintenant que les quatre panneaux principaux sont connectés à l'arrière, utilisez les 3 plaques de base (9) et placez-les entre chaque panneau à l'avant.
5. Alignez et utilisez 4 vis B par plaque de base. Utilisez 12 vis B au total pour cette section. Voir l'image 7 pour vérifier vos progrès.

IMAGE 6

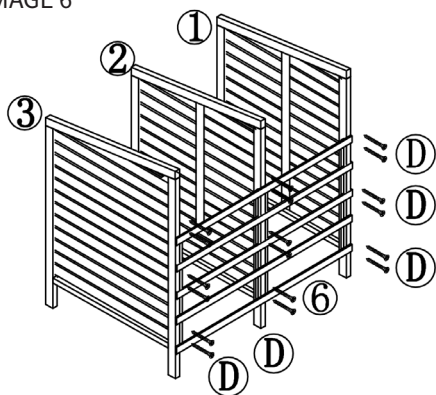
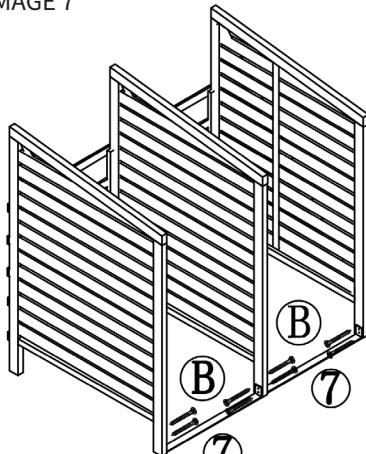

IMAGE 7



6. Connectez maintenant les panneaux de couvercle (5, 6, & 7). Placez le premier panneau de couvercle sur le panneau latéral droit (1) et le premier panneau central (2).
7. À l'aide de 4 vis C, visser en place. Regardez l'image 8. Le couvercle est fixé à l'arrière de la remise. Voir l'image 8A. C'est ici que vous devez placer les vis.
8. Répétez ce processus pour les panneaux de couvercle restants.



# GUIDE D'UTILISATION

## INSTRUCTIONS DE MONTAGE

### TRIPLE POUBELLE À ROULETTE

IMAGE 8

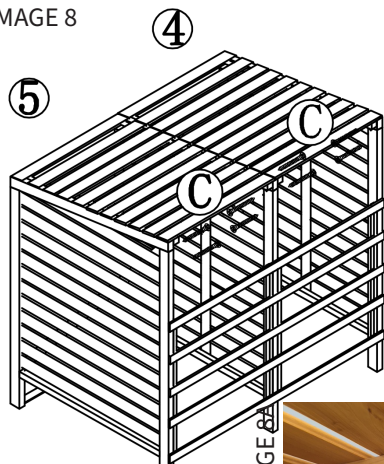
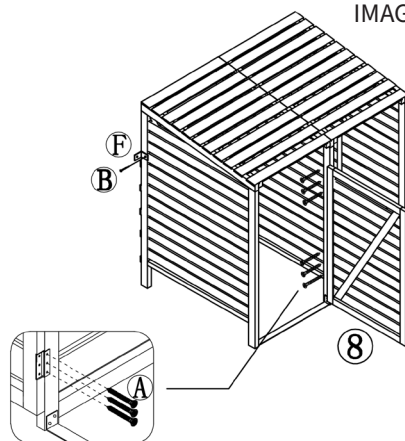

IMAGE 9



9. Lorsque vous fixez les portes, notez que les portes s'ouvrent vers l'extérieur à partir des Panneaux Centraux (2 et 3).
10. Alignez la Porte Droite (12) et utilisez 6 Vis A pour attacher. Répétez l'opération pour fixer la porte gauche (10) et la porte centrale (11) en vous rappelant de fixer la charnière dans les panneaux centraux (3 et 4). Voir Image 4 pour référence.

**Remarque:** S'il est nécessaire, vous pouvez fixer le meuble à roulettes sur une autre surface pour vous assurer qu'il reste solide et en place. Pour ce faire, utilisez des vis 4 x B pour fixer les supports muraux à la structure, puis utilisez des vis 4 x B pour les fixer à une autre surface.

# GUIDE D'UTILISATION

## INSTRUCTIONS DE MONTAGE

### TRIPLE POUBELLE À ROULETTE

11. Fixez maintenant la chaîne du couvercle en utilisant 1 vis A par chaîne dans le panneau approprié. Voir l'image 10.
12. Pour fixer les supports de verrouillage (E), connectez d'abord les bases de verrouillage au panneau gauche de la porte gauche (10) et de la porte centrale (11) et au panneau droit de la porte droite (12) en utilisant 4 x A Vis chacun (12 vis A au total). Vérifiez avec l'image 10 pour l'exactitude.
13. Fixez les mécanismes de verrouillage directement sur les trois portes (10, 11, 12) à l'aide de 2 vis A x chacune (6 vis A au total). Voir l'image 10 pour référence.

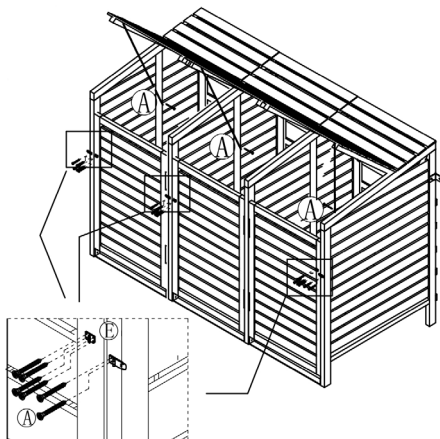

# DÉPANNAGE

## GUIDE DE RÉOLUTION DES PANNES

### QUE FAIRE S'IL Y A UNE PARTIE DE MA COMMANDE QUI MANQUE?

Au cas où il y aurait des pièces manquantes dans votre commande, contactez notre aimable équipe d'assistance clientèle dans les 7 jours suivant sa réception.

### QU'EST-CE QUE JE FAIS SI MON UNITÉ DE STOCKAGE DE BAC EST DE TRAVERS OU FRAGILE?

La conception des bacs de stockage signifie qu'il doit être solide et carré. Si ce n'est pas le cas, il est probable qu'il n'a pas encore été assemblé correctement. Revenez aux instructions de montage et suivez-les attentivement. Serrer les vis autant que possible, et s'assurer que vous vous assemblez avec au moins une autre personne.

### QU'EST-CE QUE JE FAIS SI LES PARTIES NE VONT PAS BIEN ENSEMBLE?

Vérifiez que vous avez suivi les instructions avec précision. Il est généralement considéré comme la meilleure pratique pour s'assurer que les panneaux vont ensemble et sont affleurants avant de les visser. Cela peut également améliorer la rigidité.

### QU'EST-CE QUE JE FAIS SI JE VEUX METTRE MON UNITÉ DE STOCKAGE DE BAC DEHORS?

Le matériau de ce Bin Storage est traité en bois FSC, ce qui signifie qu'il convient à une utilisation en extérieur et qu'il résiste bien à la pluie, au vent et à d'autres conditions.

**POUR TOUTE AUTRE PREOCCUPATION, VEUILLEZ  
CONTACTER NOTRE ÉQUIPE DE SERVICE CLIENT.**



# SPEZIFIKATIONEN

## PRODUKTBE SCHREIBUNG

Vielen Dank für den Kauf dieses Mülltonnen-Lagerschuppens. Sie schauen aus dem Fenster. Ihr Garten sieht großartig aus. Die investierte Zeit und harte Arbeit hat sich ausgezahlt. Aber der Ausblick wird behindert, ruiniert durch unschöne, grässliche Mülltonnen. Das ist ein Problem, das uns bei Monster Group UK selbst plagt, bis jetzt!

Der Lagerschuppen für Mülltonnen kann zwei oder drei 240 Liter Mülltonnen nach UK Standard verstecken (abhängig von Ihrer Bestellung). Auf diese Weise gewinnen Sie den tollen Anblick Ihres Gartens zurück! Durch den schnellen und einfachen Aufbau, durch das Anheben der an Ihren Mülltonnen befestigten Deckeln und dem behandelten, nachhaltigen hergestellten und langlebigen Holz mit großartigem Finish, müssen Sie nie mehr unter diesem unschönen Anblick leiden! Wir wissen ganz genau, dass Sie dieses Produkt lieben werden!

**WARNUNG:** Die Montage dieses Produkts erfordert zwei Personen. Versuchen Sie nicht, die Montage alleine vorzunehmen.

Bitte lesen Sie vor dem Start den Sicherheitshinweis, eine Anleitung zur sicheren Arbeitspraxis, um Verletzungen oder Schäden am Gerät zu vermeiden.

## PRODUKTEIGENSCHAFTEN



	DOPPEL LAGERUNG	DREIFACH LAGERUNG
ABMESSUNG (H x B x T):	122 x 149 x 92cm	120 x 198 x 81cm
GEWICHT:	25.5KG	31.5KG
MATERIAL:	Tanne	Tanne

Die Haftung von Monster Group UK Limited ist auf den Handelswert des Produkts beschränkt.

# SPEZIFIKATIONEN

## LIEFERUMFANG

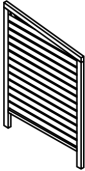

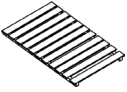
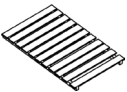
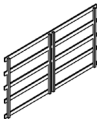
### DOPPEL LAGERUNG





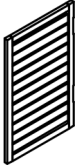

PART NO.	PART NAME	QUANTITY	DIAGRAM
1	Rechte Seitenwand	1	
2	Mittlere Wand	1	
3	Linke Seitenwand	1	
4	Abdeckung	1	
5	Abdeckung	1	
6	Rückwand	1	

# SPEZIFIKATIONEN

## LIEFERUMFANG

### DOPPEL LAGERUNG



PART NO.	PART NAME	QUANTITY	DIAGRAM
7	Grundplatte	2	
8	Linke Tür	1	
9	Rechte Tür	1	

PART NO.	PART NAME	QUANTITY	DIAGRAM
A	Schraube	26	 $\phi 3*16\text{mm}$
B	Schraube	12	 $\phi 3.5*20\text{mm}$
C	Schraube	8	 $\phi 3.5*35\text{mm}$
D	Schraube	18	 $\phi 3.5*25\text{mm}$
E	Verriegelungsklamme	2	
F	Wandhalterung	2	

# SPEZIFIKATIONEN

## LIEFERUMFANG

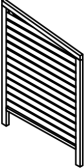

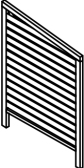
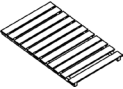
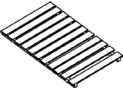
### DREIFACH LAGERUNG

PART NO.	PART NAME	QUANTITY	DIAGRAM
1	Rechte Seitenwand	1	
2	Mittlere Wand	1	
3	Mittlere Wand	1	
4	Linke Seitenwand	1	
5	Abdeckung	1	
6	Abdeckung	1	

# SPEZIFIKATIONEN

## LIEFERUMFANG

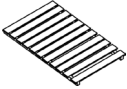
### DREIFACH LAGERUNG

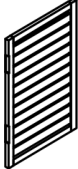
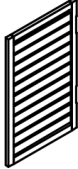
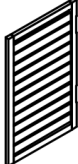





PART NO.	PART NAME	QUANTITY	DIAGRAM
7	Abdeckung	1	
8	Rückwand	1	
9	Grundplatte	3	
10	Linke Tür	1	
11	Mittlere Tür	1	
12	Rechte Tür	1	



# SPEZIFIKATIONEN

## LIEFERUMFANG

### DREIFACH LAGERUNG

PART NO.	PART NAME	QUANTITY	DIAGRAM
A	Schraube	39	 $\phi 3*16\text{mm}$
B	Schraube	16	 $\phi 3.5*20\text{mm}$
C	Schraube	12	 $\phi 3.5*35\text{mm}$
D	Schraube	24	 $\phi 3.5*25\text{mm}$
E	Verriegelungsklamme	3	
F	Wandhalterung	2	

# SICHERHEITSHINWEISE

## SICHERE ARBEITSPRAXIS

Bitte lesen Sie die Sicherheitshinweise, um Verletzungen oder Schäden am Gerät zu vermeiden.

Die Aufbauanweisungen in dieser Anleitung sollten streng und mit Vorsicht Folge geleistet werden.

Sie sollten mit einer anderen Person arbeiten, während des Aufbaues und Heben des Produkts. Versuchen Sie niemals dieses ohne Hilfe zu Heben.

Sie sollten keine Änderungen des Design oder Aufbau des Produktes vornehmen.

# BENUTZERHANDBUCH

## MONTAGEANLEITUNGEN

### DOPPEL-MÜLLTONNEN-LAGERUNG

1. Richten Sie die rechte Seitenwand (1), linke Seitenwand (3) und die mittlere Wand (2) wie in Abbildung 1 aus.
2. Verwenden Sie die Rückwand (6), um alle drei Teile zu verbinden und verwenden Sie 6 x D-Schrauben pro Teil.
3. Wenn Sie sich Abbildung 6 genauer anschauen, werden Sie feststellen, dass die Rückwand (6) fünf Arme auf jeder Seite hat. Die Schrauben müssen am oberen, unteren und mittleren Arm befestigt werden.

**Hinweis: Überprüfen Sie die Gesamtanzahl von 18 x D Schrauben, wie in Abbildung 1.**

4. Da die drei Hauptplatten nun von der Rückwand aus verbunden sind, verwenden Sie 2 x Grundplatten (7) und platzieren Sie diese zwischen jede Wand an der Vorderseite.
5. Richten Sie diese aus und verwenden Sie 4 x B-Schrauben pro Grundplatte. Verwenden Sie 8 x B-Schrauben insgesamt für diesen Abschnitt. Siehe Abbildung 2 zur Überprüfung des Fortschritts.

IMAGE 1

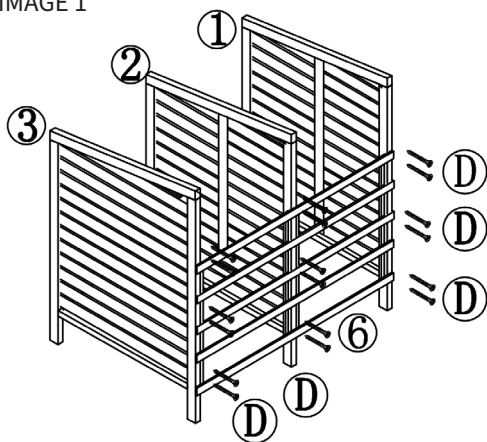
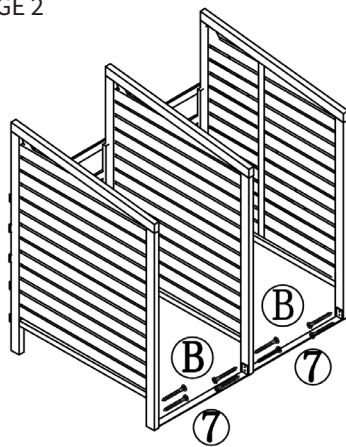

IMAGE 2



6. Platzieren Sie die erste Abdeckung (4) oben auf die rechte Seitenwand (1) und auf die mittlere Wand (2). Verwenden Sie 4 x C-Schrauben, fest anziehen.
7. Siehe Abbildung 3. Der Deckel wird an der Rückseite des Lagerschuppens befestigt. Siehe Abbildung 3A. Hier müssen Sie die Schrauben platzieren. Wiederholen Sie diesen Vorgang für die nächste Abdeckung (5).
8. Beachten Sie beim Anbringen der Türen, dass die Scharniere in der mittleren Wand (2) sitzen und die Türen von der mittleren Wand aus nach außen schwingen.
9. Richten Sie die rechte Tür (9) und verwenden Sie 6 x A-Schrauben zum Befestigen. Wiederholen Sie den Vorgang, um die linke Tür (8) zu befestigen. Denken Sie daran, das Scharnier von der mittleren Wand (2) aus zu befestigen. Siehe Abbildung 4 als Referenz.

# BENUTZERHANDBUCH

## MONTAGEANLEITUNGEN

### DOPPEL-MÜLLTONNEN-LAGERUNG

Hinweis: Falls erforderlich, können Sie den Mülltonnen-Lagerschuppen auf einer anderen Oberfläche befestigen, um die Stabilität sicherzustellen. Verwenden Sie dazu 4 x B-Schrauben, um die Wandhalterung zu befestigen. Anschließend verwenden Sie 4 x B-Schrauben zur Befestigung an einer anderen Oberfläche.

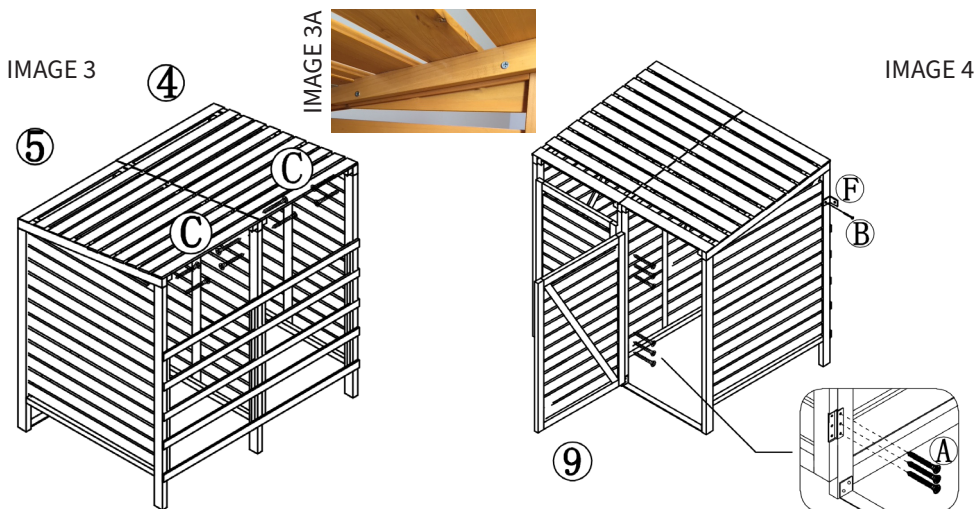
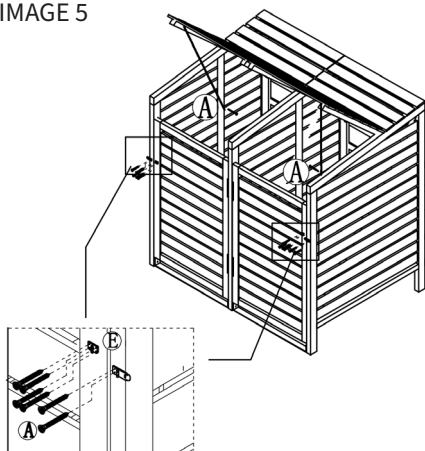

IMAGE 5



10. Now Befestige Sie nun die Deckelkette mit 1 x A-Schraube pro Kette in die entsprechende Platte. Siehe Abbildung 5 als Referenz.
11. Um die Schlosshalterung (E) zu befestigen, verbinden Sie zuerst das Schlossgehäuse an der linken und rechten Seitenwand (1 und 3) mit jeweils 4 x A-Schrauben (8 x A-Schrauben insgesamt).
12. Befestigen Sie dann den Verriegelungsmechanismus an den linken und rechten Türen (8 und 9) mit jeweils 2 x A-Schrauben (4 x A-Schrauben insgesamt). Siehe Abbildung 5 als Referenz.

# BENUTZERHANDBUCH

## MONTAGEANLEITUNGEN

### DREIFACH- MÜLLTONNEN- LAGERUNG

1. Richten Sie die rechte Seitenwand (1), linke Seitenwand (4) und beide mittleren Wände (2 und 3) wie in Abbildung 6 aus.
2. Verwenden Sie die Rückwand (8), um alle vier Teile zu verbinden und verwenden Sie 6 x D-Schrauben pro Teil.
3. Wenn Sie sich Abbildung 6 genauer anschauen, werden Sie feststellen, dass die Rückwand (8) fünf Arme auf jeder Seite hat. Die Schrauben müssen am oberen, unteren und mittleren Arm befestigt werden.

**Hinweis: Überprüfen Sie die Gesamtanzahl von 24 x D Schrauben, wie in Abbildung 6.**

4. Da die vier Hauptplatten nun von der Rückwand aus verbunden sind, verwenden Sie 3 x Grundplatten (9) und platzieren Sie diese zwischen jede Wand an der Vorderseite.
5. Richten Sie diese aus und verwenden Sie 4 x B-Schrauben pro Grundplatte. Verwenden Sie 12 x B-Schrauben insgesamt für diesen Abschnitt. Siehe Abbildung 7 zur Überprüfung des Fortschritts.

IMAGE 6

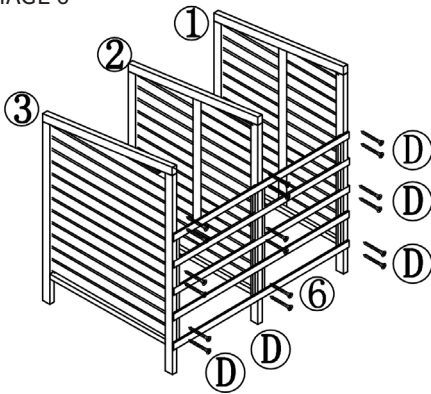
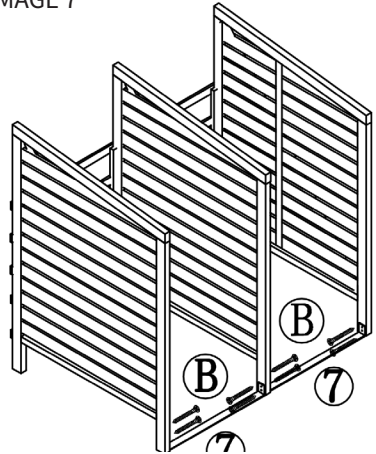

IMAGE 7



6. Verbinden Sie nun die Abdeckungen (5, 6, und 7). Platzieren Sie die erste Abdeckung oben auf die rechte Seitenwand (1) und die erste mittlere Wand (2).
7. Verwenden Sie 4 x C-Schrauben, fest anziehen. Siehe Abbildung 8. Der Deckel wird an der Rückseite des Lagerschuppens befestigt. Siehe Abbildung 8A. Hier müssen Sie die Schrauben platzieren. Wiederholen Sie diesen Vorgang für die restlichen Abdeckungen.

# BENUTZERHANDBUCH

## MONTAGEANLEITUNGEN

### DREIFACH- MÜLLTONNEN- LAGERUNG

IMAGE 8

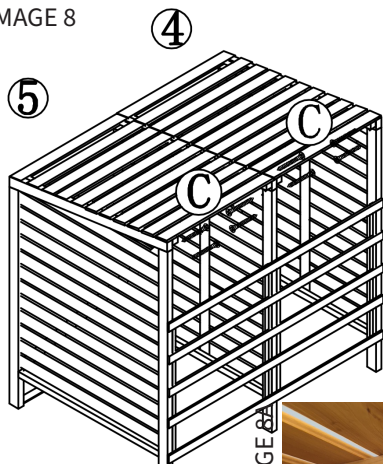
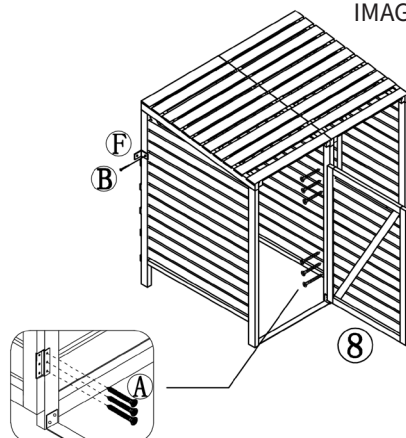

IMAGE 8



IMAGE 9



9. When Beachten Sie beim Anbringen der Türen, dass diese von den mittleren Wänden (2 und 3) aus nach außen schwingen.
10. Richten Sie die rechte Türe (12) aus und verwenden Sie 6 x A-Schrauben zum Befestigen. Wiederholen Sie den Vorgang, um die linke Türe (10) und die mittlere Türe (11) zu befestigen. Denken Sie daran, das Scharnier von den mittleren Wänden (3 und 4) aus zu befestigen. Siehe Abbildung 4 als Referenz.

**HINWEIS:** Falls erforderlich, können Sie den Mülltonnen-Lagerschuppen auf einer anderen Oberfläche befestigen, um die Stabilität sicherzustellen. Verwenden Sie dazu 4 x B-Schrauben, um die Wandhalterung zu befestigen. Anschließend verwenden Sie 4 x B-Schrauben zur Befestigung an einer anderen Oberfläche.

# BENUTZERHANDBUCH

## MONTAGEANLEITUNGEN

### DREIFACH- MÜLLTONNEN- LAGERUNG

11. Now Befestige Sie nun die Deckelkette mit 1 x A-Schraube pro Kette in die entsprechende Platte. Siehe Abbildung 10.
12. Um die Schlosshalterung (E) zu befestigen, verbinden Sie zuerst das Schlossgehäuse an der linken (10) und mittleren Türe (11) und an der Wand rechts von der rechten Türe (12) mit jeweils 4 x A-Schrauben (12 x A-Schrauben insgesamt).
13. Überprüfen Sie mit Abbildung 10 auf Genauigkeit. Befestigen Sie den Verriegelungsmechanismus direkt an den alle drei Türen (10, 11 und 12) mit jeweils 2 x A-Schrauben (6 x A-Schrauben insgesamt). Siehe Abbildung 10 als Referenz.

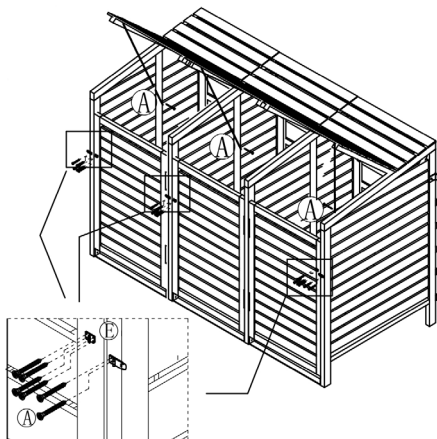

# FEHLERBEHEBUNG

## ANLEITUNG ZUR PROBLEMLÖSUNG

### WAS MACHE ICH, WENN IN MEINER BESTELLUNG TEILE FEHLEN?

Wenn in Ihrer Bestellung ein Teil fehlt, wenden Sie sich innerhalb von 7 Tagen nach Erhalt an unser freundliches und hilfsbereites Kundendienstteam.

### WAS SOLL ICH TUN, WENN MEIN LAGERSCHUPPEN SCHIEF IST ODER WACKELT?

Aufgrund des Designs sollte der Lagerschuppen solide und quadratisch sein. Falls dies nicht der Fall ist, wurde er womöglich nicht richtig zusammengebaut. Lesen Sie sich erneut die Montageanweisungen durch und befolgen Sie diese genau. Ziehen Sie die Schrauben so fest wie möglich an. Stellen Sie darüber hinaus sicher, den Lagerschuppen mit mindestens einer weiteren Person zusammenzubauen.

### WAS SOLL ICH TUN, WENN DIE TEILE NICHT RICHTIG ZUSAMMENPASSEN?

Stellen Sie sicher, dass Sie die Anweisungen genau befolgt haben. Im Allgemeinen ist die beste Vorgehensweise, vor dem Verschrauben zu überprüfen, ob die Wände zusammenpassen und bündig sind. Dadurch wird auch die Stabilität erhöht.

### WAS SOLL ICH TUN, WENN ICH MEINEN LAGERSCHUPPEN INS FREIE STELLEN MÖCHTE?

Der Lagerschuppen besteht aus behandeltem FSC-Holz. Somit kann er im Freien aufgestellt werden und hält Regen, Wind und anderen Wetterbedingungen stand.

**FÜR ALLE ANDEREN FRAGEN WENDEN SIE SICH  
BITTE AN UNSER KUNDENDIENSTTEAM.**



# ESPECIFICACIONES

## DESCRIPCIÓN DEL PRODUCTO

Gracias por comprar este cobertizo para contenedores de basura con ruedas. Mira por su ventana. Su jardín se ve espléndido. Todo el tiempo y trabajo duro parecen haber valido la pena. Pero su vista se ve obstaculizada por feos contenedores de basura. Este es un problema que nosotros en Monster Group UK también teníamos, ¡hasta ahora!

El Cobertizo para contenedores de Basura oculta de forma perfecta dos o tres (dependiendo de su pedido) Contenedores de Basura con ruedas 240L estándar del Reino Unido y ¡le ayuda a recuperar su jardín! Con su ensamble rápido y fácil, sus tapas unidas a la parte superior de su contenedor y madera tratada de origen ético, la cual es duradera y posee un acabado de gran apariencia, puede sentirse aliviado de no tener que soportar esas vistas desagradables nuevamente. ¡Sabemos que le encantará!

**Advertencia: Se requiere de dos personas para el ensamblaje de este producto. No intente realizar el ensamblado por su cuenta.**

Consulte y lea Consejos de seguridad, Prácticas de trabajo seguro para garantizar la prevención de lesiones o daños al producto antes de comenzar.

## ESPECIFICACIONES DEL PRODUCTO

	DOBLE ALMACENAMIENTO	TRIPLE ALMACENAMIENTO
DIMENSIONES (A x An x L):	122 x 149 x 92cm	120 x 198 x 81cm
PESO:	25.5KG	31.5KG
MATERIAL:	Abeto	Abeto



La responsabilidad de Monster Group UK Limited estará limitada únicamente al valor comercial del producto.



# ESPECIFICACIONES

## CONTENIDO DEL ARTÍCULO

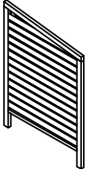
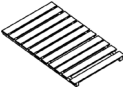
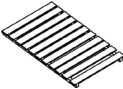
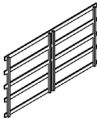

### DOBLE ALMACENAMIENTO





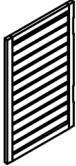

PART NO.	PART NAME	QUANTITY	DIAGRAM
1	Panel Lateral Derecho	1	
2	Panel Central	1	
3	Panel Lateral Izquierdo	1	
4	Panel de la Tapa	1	
5	Panel de la Tapa	1	
6	Panel Trasero	1	

# ESPECIFICACIONES

## CONTENIDO DEL ARTÍCULO

### DOBLE ALMACENAMIENTO



PART NO.	PART NAME	QUANTITY	DIAGRAM
7	Placa Base	2	
8	Puerta Izquierda	1	
9	Puerta Derecha	1	

PART NO.	PART NAME	QUANTITY	DIAGRAM
A	Tornillo	26	 $\phi 3*16\text{mm}$
B	Tornillo	12	 $\phi 3.5*20\text{mm}$
C	Tornillo	8	 $\phi 3.5*35\text{mm}$
D	Tornillo	18	 $\phi 3.5*25\text{mm}$
E	Soporte del Seguro	2	
F	Soporte de Pared	2	

# ESPECIFICACIONES

## CONTENIDO DEL ARTÍCULO

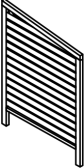

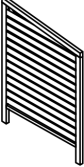
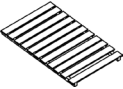
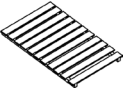
### TRIPLE ALMACENAMIENTO

PART NO.	PART NAME	QUANTITY	DIAGRAM
1	Panel Lateral Derecho	1	
2	Panel Central	1	
3	Panel Central	1	
4	Panel Lateral Izquierdo	1	
5	Panel de la Tapa	1	
6	Panel de la Tapa	1	

# ESPECIFICACIONES

## CONTENIDO DEL ARTÍCULO

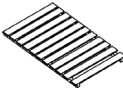

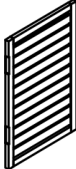
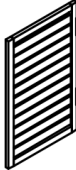
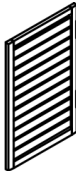



### TRIPLE ALMACENAMIENTO

PART NO.	PART NAME	QUANTITY	DIAGRAM
7	Panel de la Tapa	1	
8	Panel Trasero	1	
9	Placa Base	3	
10	Puerta Izquierda	1	
11	Puerta Central	1	
12	Puerta Derecha	1	

# ESPECIFICACIONES

## CONTENIDO DEL ARTÍCULO

### TRIPLE ALMACENAMIENTO

PART NO.	PART NAME	QUANTITY	DIAGRAM
A	Tornillo	39	 $\phi 3*16\text{mm}$
B	Tornillo	16	 $\phi 3.5*20\text{mm}$
C	Tornillo	12	 $\phi 3.5*35\text{mm}$
D	Tornillo	24	 $\phi 3.5*25\text{mm}$
E	Soporte del Seguro	3	
F	Soporte de Pared	2	

# CONSEJOS DE SEGURIDAD

## PRÁCTICAS DE TRABAJO SEGURAS

Asegúrese de haber leído y comprendido completamente el manual de instrucciones y los consejos de seguridad antes de utilizar este producto.

Las instrucciones de montaje establecidas en este manual deben seguirse estricta y cuidadosamente.

Siempre debe trabajar junto a otro al ensamblar y levantar este artículo. Nunca intente levantar el artículo sin ayuda.

No debe intentar modificar o cambiar el montaje o diseño de este artículo.

# GUÍA DE USUARIO

## INSTRUCCIONES DE MONTAJE

### CONTENEDOR DE ALMACENAMIENTO DE DOBLE RUEDA

1. Alinee el panel lateral derecho (1), el panel lateral izquierdo (3) y el panel central (2) como en la imagen 1.
2. Use el panel posterior (6) para conectar los tres paneles y use 6 tornillos D por panel para colocarlo.
3. Si mira detenidamente la Imagen 6, notará que el Panel posterior (6) tiene cinco brazos a cada lado. Los tornillos deben sujetarse por los brazos superior, inferior y medio.

**NOTA: Verifique que haya usado 18 tornillos D en total, como en la Imagen 1.**

4. Ahora que los tres paneles principales están conectados desde la parte posterior, utilice 2 placas de base (7) y colóquelas entre cada panel en la parte delantera.
5. Alinee y use 4 tornillos B por placa base. Utilice 8 tornillos B en total para esta sección. Vea la Imagen 2 para verificar su progreso.

IMAGE 1

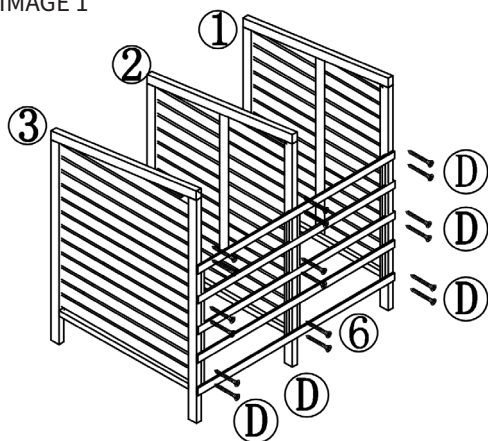
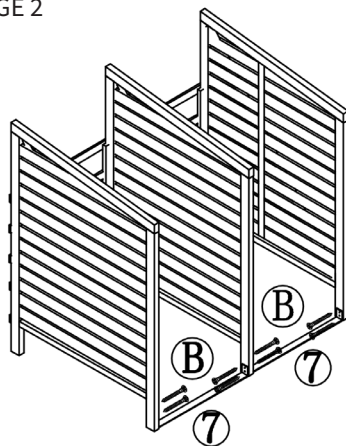

IMAGE 2



6. Coloque el primer panel de la tapa (4) sobre el panel lateral derecho (1) y el panel central (2). Usando 4 tornillos C, apriete en su lugar.
7. Mire la Imagen 3. La tapa está unida a la parte posterior del cobertizo de almacenamiento. Ver imagen 3A. Aquí es donde debe colocar los tornillos. Repita este proceso para el próximo Panel de tapa (5).
8. Al colocar las puertas, tenga en cuenta que las bisagras se encuentran dentro del panel central (2) y las puertas se abren hacia afuera desde el panel central. Alinee la puerta derecha (9) y use 6 tornillos A para colocarla.
9. Repita para colocar la Puerta Izquierda (8), sin olvidar colocar la bisagra dentro del Panel Central (2). Ver imagen 4 para referencia.

# GUÍA DE USUARIO

## INSTRUCCIONES DE MONTAJE

### CONTENEDOR DE ALMACENAMIENTO DE DOBLE RUEDA

NOTA: Si es necesario, puede conectar el cobertizo a otra superficie para asegurarse de que permanezca firme y en su lugar. Para hacerlo, use 4 tornillos B para unir los soportes de pared a la estructura, luego use 4 tornillos B para colocarlos en otra superficie.

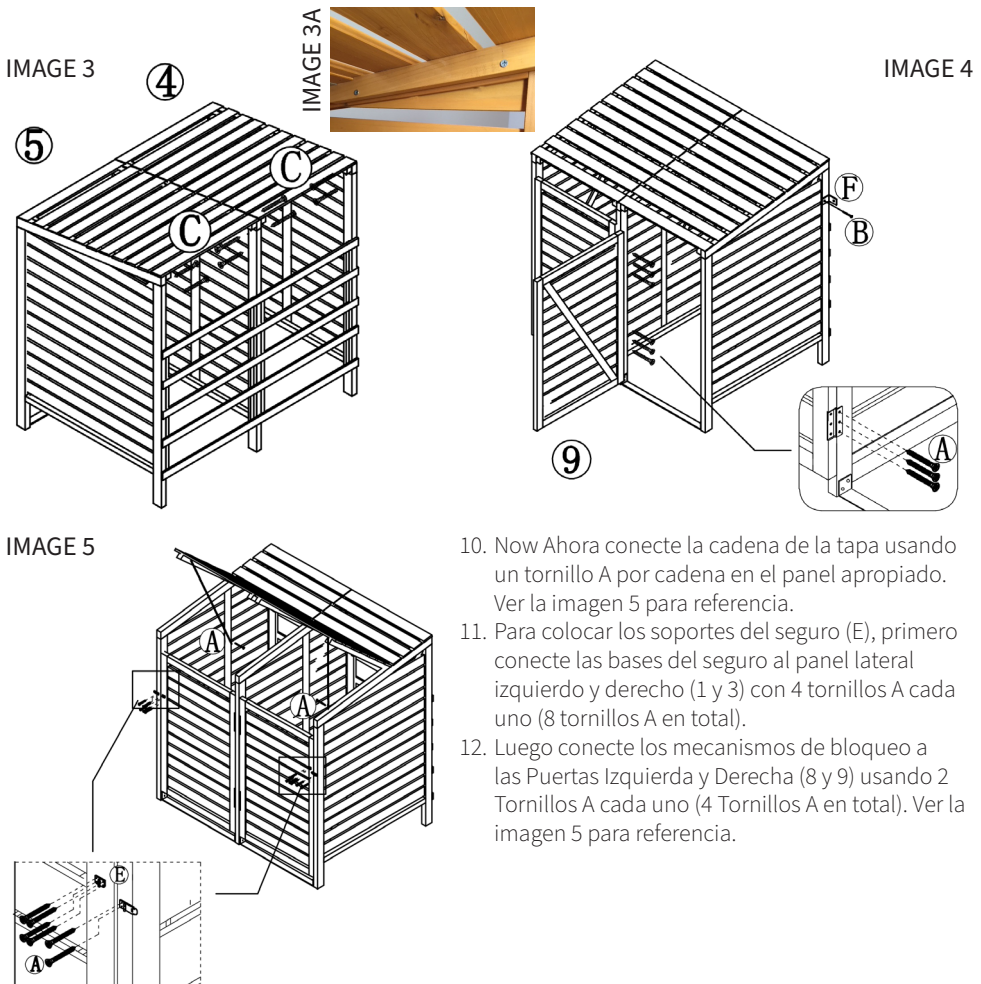

# GUÍA DE USUARIO

## INSTRUCCIONES DE MONTAJE

### CONTENEDOR DE ALMACENAMIENTO DE TRIPLE RUEDA

1. Alinee el panel lateral derecho (1), el panel lateral izquierdo (4) y ambos paneles centrales (2 y 3) como en la imagen 6.
2. Utilice el panel posterior (8) para conectar los cuatro paneles y use 6 tornillos D por panel para unirlos.
3. Si observa detenidamente la Imagen 6, notará que el Panel Posterior (8) tiene cinco brazos a cada lado. Los tornillos deben sujetarse por los brazos superior, inferior y medio.

**NOTA: Verifique que haya usado 24 tornillos D en total, como en la Imagen 6.**

4. Ahora que los cuatro paneles principales están conectados en la parte posterior, utilice las 3 placas de base (9) y colóquelas entre cada panel en la parte delantera.
5. Alinee y use 4 tornillos B por placa base. Utilice 12 tornillos B en total para esta sección. Vea la Imagen 7 para verificar su progreso.

IMAGE 6

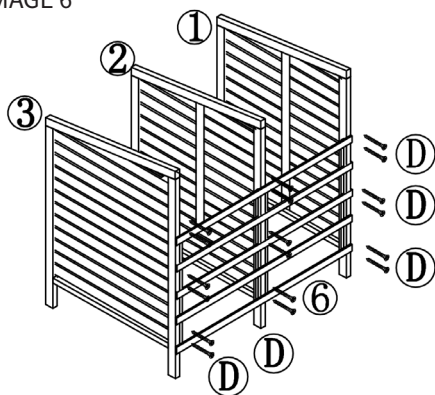
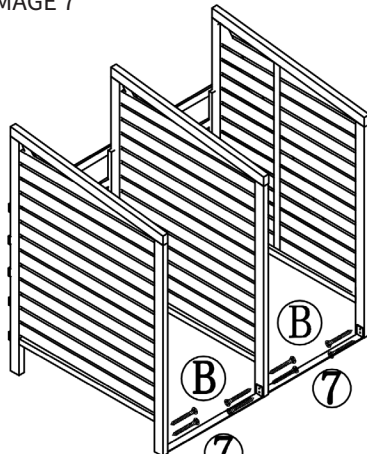

IMAGE 7



6. Ahora conecte los paneles de tapa (5, 6 y 7). Coloque el primer panel de la tapa sobre el panel lateral derecho (1) y el primer panel central (2).
7. Usando 4 tornillos C, atornille en su lugar. Mire la Imagen 8. La tapa está unida a la parte posterior del cobertizo de almacenamiento. Ver imagen 8A. Aquí es donde debe colocar los tornillos.
8. Repita este proceso para los paneles de tapa restantes.



# GUÍA DE USUARIO

## INSTRUCCIONES DE MONTAJE

### CONTENEDOR DE ALMACENAMIENTO DE TRIPLE RUEDA

IMAGE 8

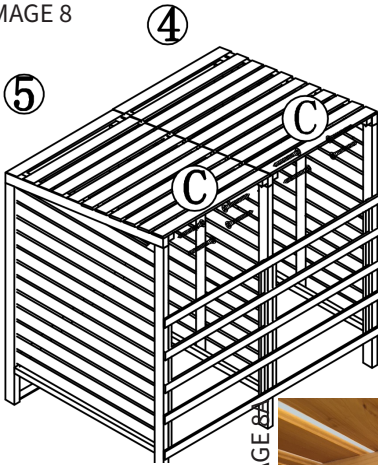
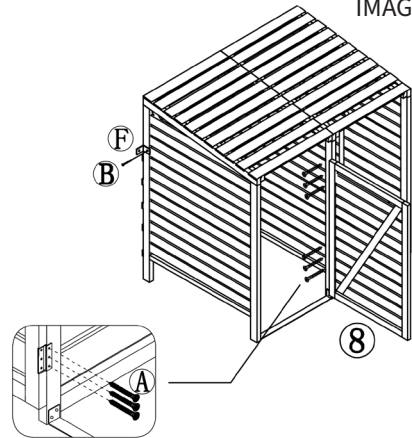

IMAGE 9



9. Al colocar las puertas, tenga en cuenta que las puertas se abren hacia afuera desde los paneles centrales (2 y 3).
10. Alinee la puerta derecha (12) y use 6 tornillos A para colocarlas. Repita para colocar la puerta izquierda (10) y la puerta central (11), sin olvidar colocar la bisagra dentro de los paneles centrales (3 y 4). Ver la imagen 4 para referencia.

**NOTA:** Si es necesario, puede conectar el cobertizo a otra superficie para asegurarse de que permanezca firme y en su lugar. Para hacerlo, use 4 tornillos B para unir los soportes de pared a la estructura, luego use 4 tornillos B para colocarlos en otra superficie.

# GUÍA DE USUARIO

## INSTRUCCIONES DE MONTAJE

### CONTENEDOR DE ALMACENAMIENTO DE TRIPLE RUEDA

11. Now aAhora conecte la cadena de la tapa usando un tornillo A por cadena en el panel apropiado. Ver la imagen 10.
12. Para colocar los soportes de bloqueo (E), primero conecte las bases del seguro al panel a la izquierda de la Puerta Izquierda (10) y la Puerta Central (11), y al panel derecho de la Puerta Derecha (12) usando 4 tornillos A cada una (12 tornillos A en total).
13. Verifique con la imagen 10. Conecte los mecanismos de bloqueo directamente en las tres puertas (10, 11, 12) con 2 tornillos A cada uno (6 tornillos A en total). Ver la imagen 10 para referencia.

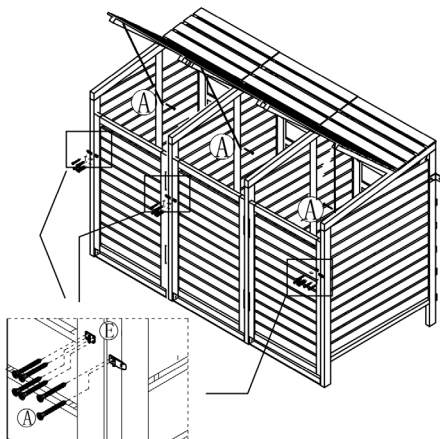

# SOLUCIÓN DE PROBLEMAS

## MANUAL DE SOLUCIONES

### ¿QUÉ HACER SI FALTA ALGUNA DE LAS PARTES AL RECIBIR EL PEDIDO?

En caso de que alguna parte esté faltante, contáctese con nuestro amable y servicial equipo de Atención al cliente dentro de los 7 días de haber recibido el pedido.

### ¿QUÉ DEBO HACER SI MI COBERTIZO DE CONTENEDORES DE BASURA ESTÁ TORCIDO O TEMBLOROSO?

El diseño de los contenedores de almacenamiento significa que deben ser sólidos y cuadrados. De no ser así, es probable que no se hayan ensamblado del todo bien. Regrese a las Instrucciones de ensamblaje y sígala con cuidado. Apriete los tornillos tanto como sea posible, y asegúrese de que se está armando con al menos 1 persona más.

### ¿QUÉ DEBO HACER SI LAS PARTES ENCAJAN BIEN JUNTAS?

Verifique que haya seguido las instrucciones con precisión. En general, se considera como una buena práctica asegurarse de que los paneles estén juntos y que queden al ras antes de atornillarlos en su lugar. Esto también puede mejorar la rigidez del cobertizo.

### ¿QUÉ DEBO HACER SI QUIERO PONER MI UNIDAD DE ALMACENAMIENTO DE CONTENEDORES DE BASURA AL AIRE LIBRE?

El material de este cobertizo madera FSC tratada, lo que significa que es adecuado para uso en exteriores y que soportará bien la lluvia, el viento y otras condiciones.

**POR CUALQUIER OTRA CONSULTA, SÍRVASE CONTACTARSE  
CON NUESTRO EQUIPO DE ATENCIÓN AL CLIENTE.**

# SPECIFICHE

## DESCRIZIONE DEL PRODOTTO

Grazie per aver acquistato il Box per Cassonetto dei Rifiuti con Ruote. Guardando fuori dalla finestra il giardino è semplicemente perfetto. Quanta fatica per ottenere un simile risultato, ma ne è valsa la pena. Tuttavia la vista è ostacolata, guastata da quei terribili cassonetti per la spazzatura. Grazie a noi di Monster Group UK questo non è più un problema!

Il Box per Cassonetto dei Rifiuti con Ruote nasconde alla perfezione fino a due o tre cassonetti standard da 240 L (a seconda dell'ordine effettuato), salvando la magia di ogni giardino! Con un assemblaggio estremamente semplice e veloce, coi suoi coperchi in legno trattato eticamente, dalla rifinitura semplicemente eccezionale, potrete stare tranquilli che il vostro lavoro non sarà più rovinato da scorci poco gradevoli. Siamo certi che lo apprezzerete!

**ATTENZIONE:** L'assemblaggio di questo prodotto richiede la collaborazione di almeno due persone. Non tentare di montarlo da soli.

Si prega di fare riferimento e leggere l'Avviso di Sicurezza, la Pratica di Lavoro Sicuro per evitare lesioni o danni al prodotto.

## SPECIFICHE PRODOTTO

### DOPPIO IMMAGAZZINAMENTO

**DIMENSIONI (H x W x D):** 122 x 149 x 92cm  
**PESO:** 25.5KG  
**MATERIALE:** Abete

### TRIPLO IMMAGAZZINAMENTO





120 x 198 x 81cm  
31.5KG  
Abete

La responsabilità di Monster Group UK Limited sarà limitata al solo valore commerciale del prodotto.

# SPECIFICHE

## CONTENUTO DELL'PRODOTTO

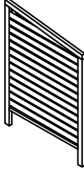
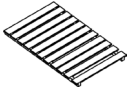

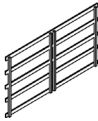
### DOPPIO IMMAGAZZINAMENTO





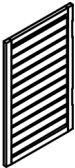

PART NO.	PART NAME	QUANTITY	DIAGRAM
1	Pannello Laterale Destro	1	
2	Pannello Centrale	1	
3	Pannello Laterale Sinistro	1	
4	Pannello Coperchio	1	
5	Pannello Coperchio	1	
6	Pannello Posteriore	1	

# SPECIFICHE

## CONTENUTO DELL'PRODOTTO

### DOPPIO IMMAGAZZINAMENTO



PART NO.	PART NAME	QUANTITY	DIAGRAM
7	Piastra Base	2	
8	Porta Sinistra	1	
9	Porta Destra	1	

PART NO.	PART NAME	QUANTITY	DIAGRAM
A	Vite	26	 $\phi 3*16\text{mm}$
B	Vite	12	 $\phi 3.5*20\text{mm}$
C	Vite	8	 $\phi 3.5*35\text{mm}$
D	Vite	18	 $\phi 3.5*25\text{mm}$
E	Staffa di Bloccaggio	2	
F	Staffa a Parete	2	

# SPECIFICHE

## CONTENUTO DELL'PRODOTTO

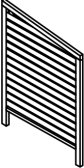

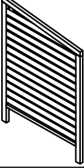
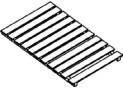
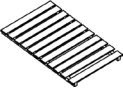
### TRIPLO IMMAGAZZINAMENTO

PART NO.	PART NAME	QUANTITY	DIAGRAM
1	Pannello Laterale Destro	1	
2	Pannello Centrale	1	
3	Pannello Centrale	1	
4	Pannello Laterale Sinistro	1	
5	Pannello Coperchio	1	
6	Pannello Coperchio	1	

# SPECIFICHE

## CONTENUTO DELL'PRODOTTO

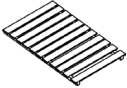
### TRIPLO IMMAGAZZINAMENTO

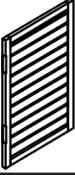
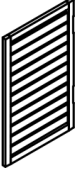
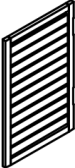





PART NO.	PART NAME	QUANTITY	DIAGRAM
7	Pannello Coperchio	1	
8	Pannello Posteriore	1	
9	Piastra Base	3	
10	Porta Sinistra	1	
11	Porta Centrale	1	
12	Porta Destra	1	



# SPECIFICHE

## CONTENUTO DELL'PRODOTTO

### TRIPLO IMMAGAZZINAMENTO

PART NO.	PART NAME	QUANTITY	DIAGRAM
A	Vite	39	 $\phi 3*16\text{mm}$
B	Vite	16	 $\phi 3.5*20\text{mm}$
C	Vite	12	 $\phi 3.5*35\text{mm}$
D	Vite	24	 $\phi 3.5*25\text{mm}$
E	Staffa di Bloccaggio	3	
F	Staffa a Parete	2	

# CONSIGLI DI SICUREZZA

## PRATICA DI LAVORO SICURA

Leggere attentamente le Procedure di Lavoro Sicuro per prevenire lesioni o danni al dispositivo.

Le istruzioni di montaggio mostrate in questo manuale devono essere seguite in maniera rigorosa.

Devi procedere con il montaggio e il sollevamento del prodotto affiancato da un'altra persona. Mai sollevare il prodotto da solo.

Non devi tentare di modificare o cambiare la modalità del montaggio o il design del prodotto.

# GUIDA DELL'UTENTE

## ISTRUZIONI DI MONTAGGIO

### DOPPIO COPRIBIDONE DELLA SPAZZATURA CON RUOTE

1. Allineare il pannello laterale destro (1), il pannello laterale sinistro (3) e il pannello centrale (2) come nell'immagine 1.
2. Utilizzare il pannello posteriore (6) per connettere tutti e tre i pannelli, avvalendosi delle 6 viti D per fissare la struttura.
3. Osservando attentamente l'immagine 6, si noter  che il pannello posteriore (6) ha cinque braccia su ogni lato. Le viti D devono essere fissate a quello superiore, quello inferiore e quello medio.

**NOTA: Verificare di aver utilizzato 18 viti D in totale, come mostrato nell'immagine 1.**

4. Ora che i tre pannelli principali sono collegati dal retro, utilizzare 2 x piastre base (7) e posizionarle tra ogni pannello anteriore.
5. Allineare e utilizzare 4 viti B per la Piastra Base. Utilizzare 8 viti B in totale per questa sezione. Vedere immagine 2 per controllare i progressi.

IMAGE 1

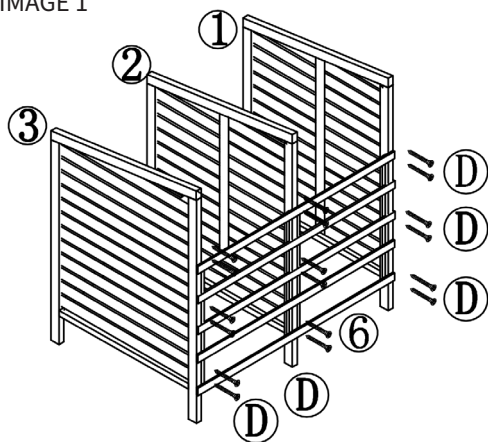
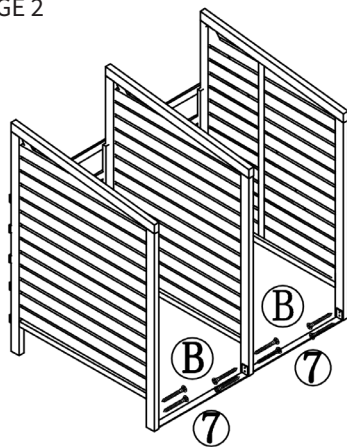

IMAGE 2



6. Posizionare il primo Pannello Coperchio (4) sul pannello laterale destro (1) e sul pannello centrale (2). Fissare in posizione utilizzando 4 viti C.
7. Consultando l'Immagine 3. Il coperchio   fissato nella parte posteriore del box. Vedere immagine 3A per comprendere dove posizionare le viti. Ripetere questa procedura per fissare il prossimo pannello coperchio (5).
8. Fissando le porte, tenere presente che le cerniere si trovano all'interno del pannello centrale (2) e che le porte scorrono verso l'esterno dal pannello centrale.
9. Allineare la porta destra (9) e utilizzare 6 viti A per fissarla. Ripetere lo stesso procedimento per attaccare la porta sinistra (8), ricordando di fissare la cerniera dall'interno del pannello centrale (2). Vedere immagine 4 per riferimento.

# GUIDA DELL'UTENTE

## ISTRUZIONI DI MONTAGGIO

### DOPPIO COPRIBIDONE DELLA SPAZZATURA CON RUOTE

NOTA: Se necessario è possibile collegare il Box per Cassonetti dei Rifiuti a un'altra superficie per far sì che rimanga solidamente in posizione. Per farlo, utilizzare 4 viti B per collegare le staffe a parete alla struttura, quindi utilizzare 4 viti x B per fissarlo a un'altra superficie.

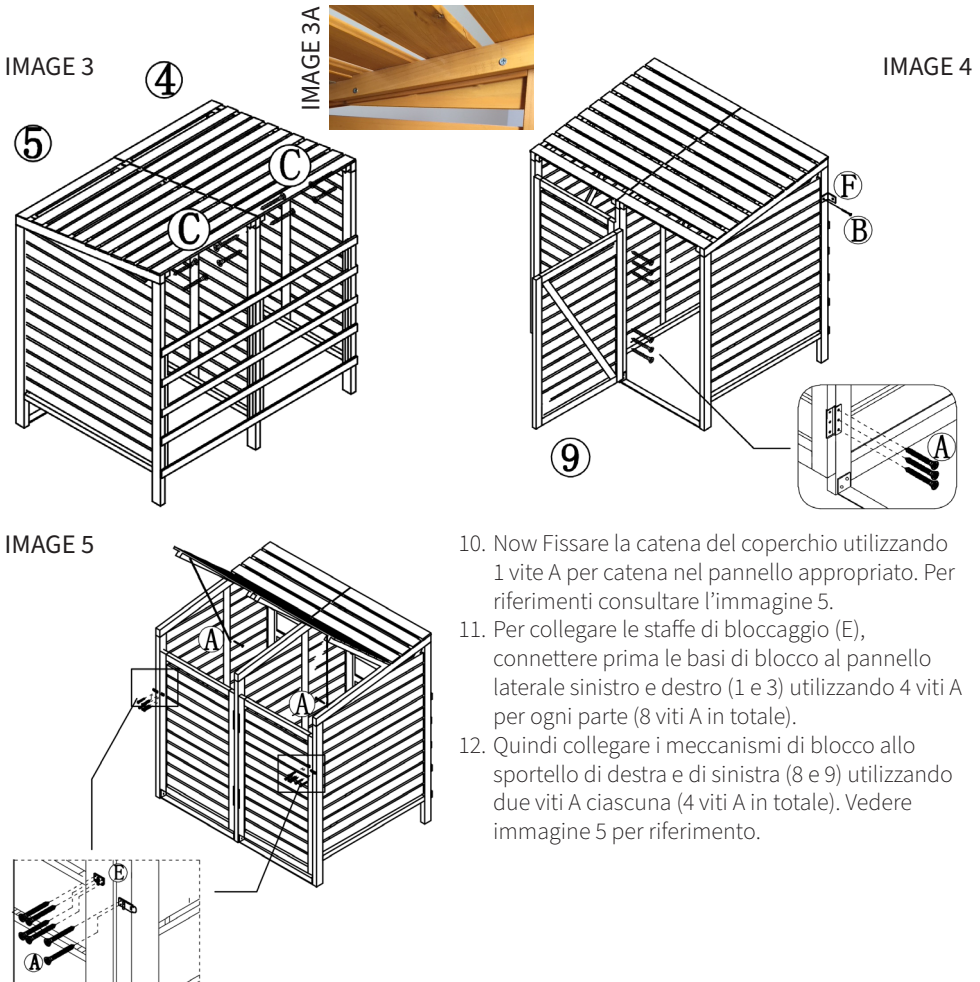

# GUIDA DELL'UTENTE

## ISTRUZIONI DI MONTAGGIO

### TRIPLO COPRIBIDONE DELLA SPAZZATURA CON RUOTE

1. Allineare il pannello laterale destro (1), il pannello laterale sinistro (4) ed entrambi i pannelli centrali (2 e 3) come nell'immagine 6.
2. Utilizzare il pannello posteriore (8) per collegare tutti e quattro i pannelli e utilizzare 6 viti D per pannello da fissare.
3. Osservando attentamente l'immagine 6, si noter  che il pannello posteriore (8) ha cinque bracci su entrambi i lati. Le viti D devono essere fissate a quello superiore, quello inferiore e quello medio.

**NOTA: Verificare di aver utilizzato 24 viti D in totale, come mostrato nell'immagine 6.**

4. Ora che i quattro pannelli principali sono collegati sul retro, utilizzare le 3 piastre base (9) e posizionarle tra i pannelli anteriori.
5. Allineare e utilizzare 4 viti B per piastra di base. Utilizzare 12 viti B in totale per questa sezione. Consultare l'immagine 7 per controllare i propri progressi.

IMAGE 6

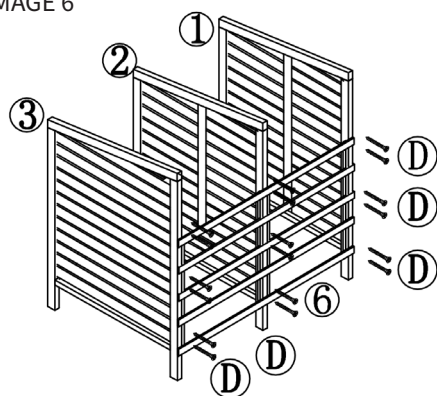
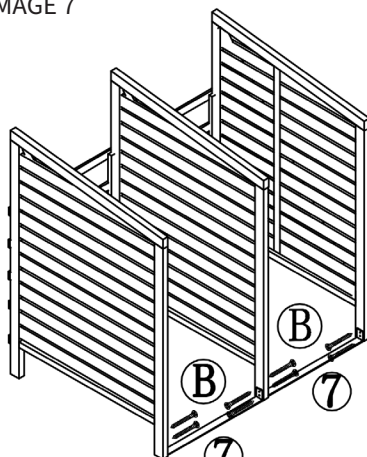

IMAGE 7



6. NowOra connettere i pannelli coperchio (5, 6 e 7). Posizionare il primo pannello di copertura in alto sul pannello laterale destro (1) e il primo pannello centrale (2).
7. Utilizzando 4 viti C, fissarle nella giusta posizione, consultando l'immagine 8 per riferimento. Il coperchio sar  fissato sul retro del box, consultare l'immagine 8A. Le viti dovranno essere posizionate in questo modo.
8. Ripetere questo passaggio per i restanti pannelli di copertura.

# GUIDA DELL'UTENTE

## ISTRUZIONI DI MONTAGGIO

### TRIPLO COPRIBIDONE DELLA SPAZZATURA CON RUOTE

IMAGE 8

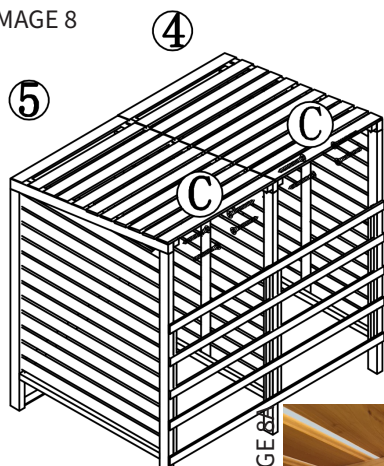

IMAGE 9

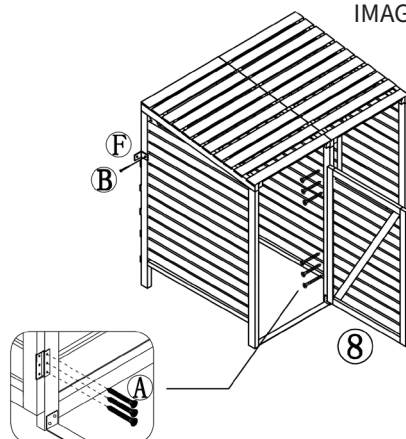

IMAGE 8



9. Quando si fissano le porte, tenere presente che queste scorreranno verso l'esterno rispetto ai pannelli centrali (2 e 3).
10. Allineare la porta destra (12) e utilizzare 12 viti A per fissarla. Ripetere lo stesso procedimento per la porta sinistra (10) fissando la cerniera all'interno dei pannelli centrali (3 e 4). Vedere l'immagine 4 per avere un riferimento.

**NOTA:** Se necessario è possibile collegare il Box per Cassonetti dei Rifiuti a un'altra superficie per far sì che rimanga solidamente in posizione. Per farlo, utilizzare 4 viti B per collegare le staffe a parete alla struttura, quindi utilizzare 4 viti x B per fissarlo a un'altra superficie.

# GUIDA DELL'UTENTE

## ISTRUZIONI DI MONTAGGIO

### TRIPLO COPRIBIDONE DELLA SPAZZATURA CON RUOTE

11. Fissare la Catena del coperchio utilizzando 1 vite A per catena nel pannello appropriato. Vedere immagine 10.
12. Per collegare le staffe di bloccaggio (E), collegare prima le basi di blocco al pannello sinistro o alla porta sinistra (10) e centrale (11), e al pannello destro della porta destra (12) utilizzando 4 viti A ciascuna (12 viti A in totale). Controllare l'immagine 10 per maggiore accuratezza.
13. Fissare i meccanismi di bloccaggio direttamente su tutte e tre le porte (10, 11, 12) utilizzando 2 viti A ciascuna (6 viti A in totale). Vedere l'immagine 10 per riferimento.

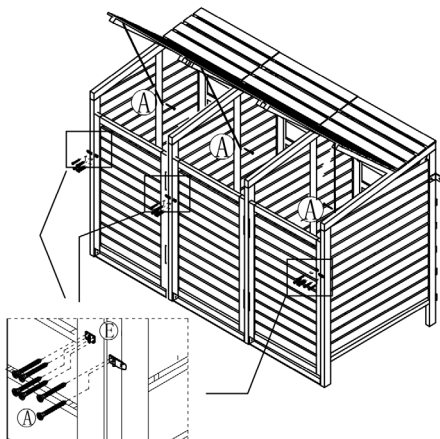

# RISOLUZIONE DEI PROBLEMI

## GUIDA ALLA RISOLUZIONE

### COSA FACCIO SE CI SONO DELLE PARTI MANCANTI NEL MIO ORDINE?

Se sembra che ci sia qualche parte mancante nel vostro ordine, contattate il nostro amichevole e disponibile Servizio di Assistenza Clienti entro 7 giorni dal ricevimento.

### COSA FACCIO SE IL BOX CHE HO RICEVUTO È STORTO O TRABALLANTE?

Il box deve risultare solido e quadrato. In caso contrario, probabilmente c'è stato qualche problema con l'assemblaggio. Recuperare le istruzioni di montaggio e seguirle attentamente. Stringere le viti il più possibili e assicurarsi di eseguire l'assemblaggio con l'aiuto di almeno un'altra persona.

### COSA FACCIO SE LE PARTI NON COMBACIANO ALLA PERFEZIONE?

Verificare che le istruzioni siano state seguite con precisione. Generalmente, è buona norma assicurarsi che i pannelli siano a filo prima di avvitarli in posizione. In questo modo la rigidità può essere aumentata.

### COSA FACCIO SE VOGLIO METTERE IL BOX ALL'ESTERNO?

Il materiale di questo Box per Cassonetti dei Rifiuti è legno FSC, ovvero adatto per l'uso all'aperto, resistente alla pioggia, al vento e alle altre intemperie.

**PER ALTRE PROBLEMATICHE CONTATTARE IL  
NOSTRO SERVIZIO DI ASSISTENZA CLIENTI.**

Monster Group (UK) is one of the UK's fastest growing online retailers. We supply a diverse range of products which offer exceptional value for money. We strive to provide the best possible customer experience with free UK delivery across all our products and a Monster Guarantee for 100% satisfaction.

For information regarding this device or other products from our Monster divisions please contact Sales.

#### SALES

TEL: 01347 878 888

EMAIL: hello@monstershop.co.uk

For queries about this device, warranty, returns or reporting faults please contact Support.

#### SUPPORT

TEL: 01347 878 887

EMAIL: help@monstershop.co.uk

Pour plus d'informations concernant cet appareil ou d'autres produits de nos divisions de Monster veuillez utiliser les détails suivants ci-dessous.

#### DÉPARTEMENT COMMERCIAL

TEL: 01347 878 888

EMAIL: bonjour@monstershop.eu

Pour les interrogations concernant cet appareil, la garantie, les retours ou les défauts de déclaration veuillez utiliser les détails suivants ci-dessous.

#### DÉPARTEMENT DE SOUTIEN

TEL: 01347 878 887

EMAIL: help@monstershop.co.uk

Para información sobre este dispositivo u otros productos de nuestras divisiones de Monster por favor use los siguientes detalles.

#### DEPARTAMENTO DE VENTAS

TEL: 01347 878 888

EMAIL: hola@monstershop.eu

Para consultas sobre este dispositivo, la garantía, devoluciones o denuncias de fallos por favor use los siguientes detalles.

#### DEPARTAMENTO DE SOPORTE

TEL: 01347 878 887

EMAIL: help@monstershop.co.uk

Für Informationen bezüglich dieses Geräts oder anderer Produkte aus unserer Monster-Abteilung, benutzen sie die folgenden unten aufgeführten Angaben.

#### VERKAUFABTEILUNG

TEL: 01347 878 888

EMAIL: hallo@monstershop.eu

Für Fragen über dieses Gerät, die Garantie, Rückgaben oder bei Störungen, benutzen sie die folgenden unten aufgeführten Angaben.

#### SUPPORT-ABTEILUNG

TEL: 01347 878 887

EMAIL: help@monstershop.co.uk

Per informazioni riguardanti questo dispositivo o altri prodotti dalle categorie Monster utilizzare i dettagli sotto riportati.

#### DIPARTIMENTO VENDITE

TEL: 01347 878 888

EMAIL: ciao@monstershop.eu

Per domande riguardo dispositivo, garanzia, reso o per riferire di guasti, utilizzare i dettagli sotto riportati.

#### DIPARTIMENTO SUPPORTO

TEL: 01347 878 887

EMAIL: help@monstershop.co.uk

Monster House, Alan Farnaby Way,  
Sheriff Hutton Industrial Estate,  
Sheriff Hutton, York, YO60 6PG  
[www.monstershop.co.uk](http://www.monstershop.co.uk)



 Try **Monster**. Buy **Monster**. Be **Monster**. 