



**24671**  
Galvanised  
Work Bench



Try **Monster** - Buy **Monster** - Be **Monster**

# Specification

## Product Description

Thank you for purchasing the Galvanised Work Bench by Monster Racking.

With three large lower shelves and two narrow high shelves, you'll be able to store all your tools and parts on the various shelving whilst using the adjustable central workbench for working on current projects and jobs.

The maximum load capacity for the workbench is an almighty 900kg, so you can store almost anything without any concern. Made from 6.8mm MDF and supported by 1.2mm galvanised steel, you'll be impressed by this high-quality workbench from Monster Racking. The workbench generously comes with a free rubber mallet for assembly and general use afterwards.

We at Monster Group UK understand this is a new and exciting purchase, and although it is tempting to get stuck in please carefully read these instructions before you start using the machine.

**Please refer to and read Safety Advice, Safe Working Practice to ensure prevention of injury or damage to the device before starting.**

## Product Specifics

Dimensions: 180cm H x 100cm W x 60cm D

Central Workbench height: Adjustable 80cm-100cm

Upper Racking Shelves x 2: 100cm W x 30cm D

Lower Racking Shelves x 3: 100cm W x 60cm D

Weight: 23 KG

Max. Load Capacity: 900 KG

Material: 6.8mm MDF and 1.2mm Galvanised Steel

Finish: Galvanised

# Specification

## Monster Guarantee

If you wish to return a product in perfect working order, we provide a 30 day returns policy as long as the item is unopened and in a resalable condition.

A 12 month warranty applies to all of our electrical products; we will cover the cost of labour and parts. Our policy is to try and repair the item before arranging an exchange or refund.

If for any reason a part is missing please get in touch with us within 7 days on receipt of your order. You can contact our friendly and helpful Customer Support Team via email or call. For full terms and conditions contact our Support Department via the details on the Contact Us page.

Monster Group UK Limited's liability will be limited to the commercial value of the product only.

# Safety Advice

## Safe Working Practice

Please read through the safe working practice to ensure prevention of injury or damage to the device.

Follow the instructions provided whilst constructing this product. Ensure you have fully understood the instructions and safety advice before proceeding with construction.

Do not use this product for anything other than its intended use.

Do not alter or modify this product in any way.

# Safety Advice

## Safe Working Practice

We recommend hiring a qualified professional to construct and/or install this racking.

Keep your construction area clear of clutter. Ensure children, pets/animals and inexperienced users are not in the vicinity when constructing.

Do not exceed the load bearing capacity of the racking. This could result in the racking toppling and causing damage to property and/or injury to persons.

Regularly inspect the product for damage and signs of wear. Tighten any components that appear to be loose.

If significant damage that threatens the stability of the racking occurs, off-load all items stored on the damaged section of the rack. The rack should not be used until full repairs have been undertaken by a qualified professional.



# User Guide

## Assembly

Use the images below to construct the Galvanised Workbench.

Each item should simply slot together. Use the rubber mallet provided if you are having difficulty connecting parts.



①

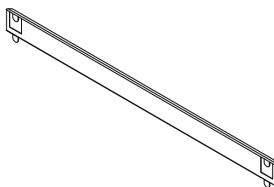

②

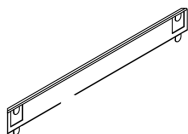

③



④

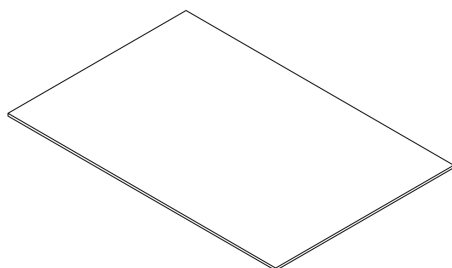

⑤

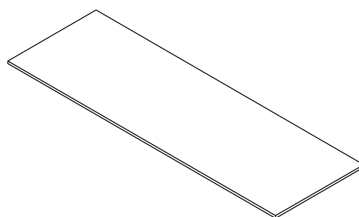

⑥

# User Guide

## Assembly Instructions

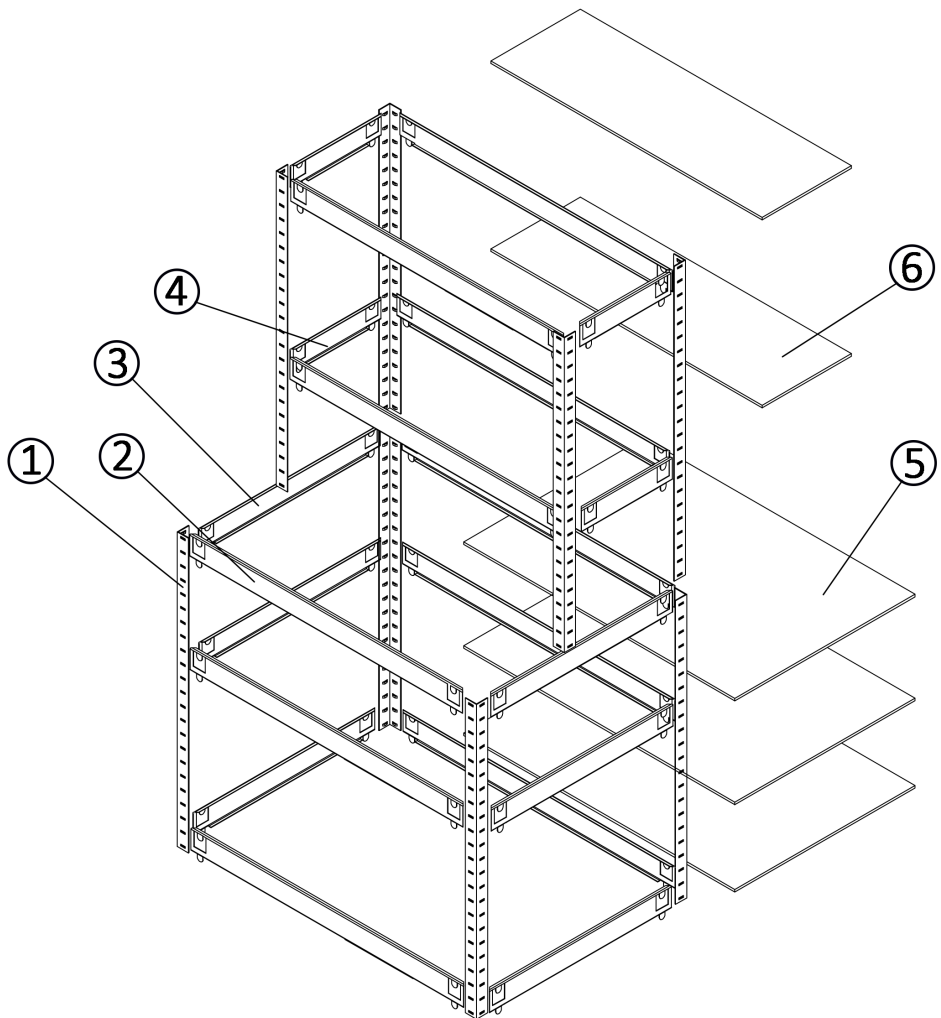

# User Guide

## Assembly Instructions

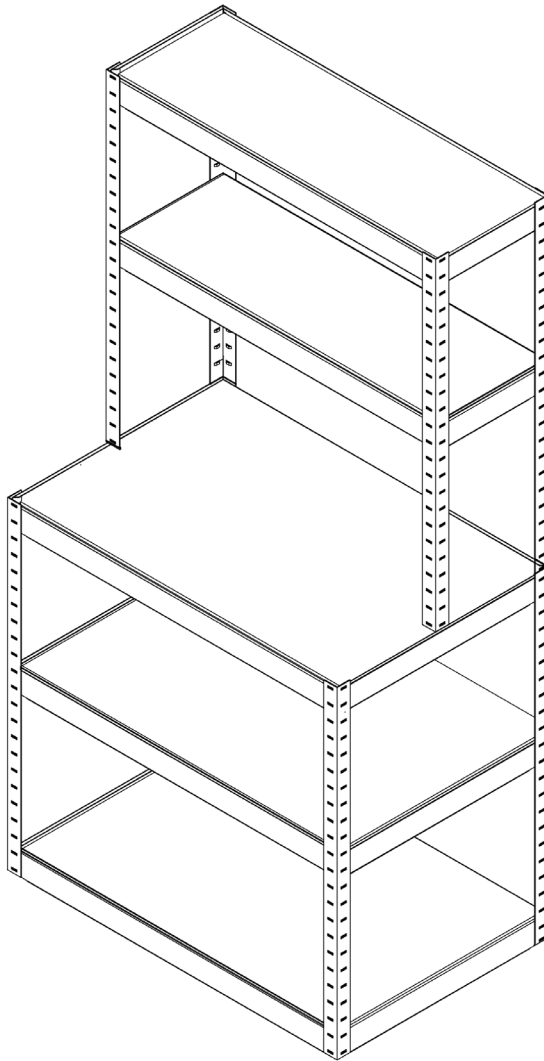

# Contact Us

## Sales Department

For information regarding this product or other products from our Monster divisions please use the following details below.

Tel: 01347 878888

Email: [hello@monstershop.co.uk](mailto:hello@monstershop.co.uk)

## Support Department

For queries about this product, warranty, returns or reporting faults please use the following details below.

Tel: 01347 878887

Email: [help@monstershop.co.uk](mailto:help@monstershop.co.uk)

## Website

To view our product range and fantastic offers in the \*\*\*\*\* division please visit our website;

[www.monstershop.co.uk](http://www.monstershop.co.uk)

## Address

To visit our office Monster House and view our products, send postal correspondence or return items our address is provided below.

Monster House, Alan Farnaby Way, Sheriff Hutton  
Industrial Estate, Sheriff Hutton, York YO60 6PG





---

Monster Group (UK) is one of the UK's fastest growing online retailers. We supply a diverse range of products which offer exceptional value for money. We strive to provide the best possible customer experience with free UK delivery across all our products and a Monster Guarantee for 100% satisfaction.

Our dedicated customer service team will be more than happy to help with any questions you may have.

Home & Garden  
Storage Shelving  
Sign & Digital  
Retail & Hospitality  
Commercial Equipment

**Check out all our Monster brands at [www.monstershop.co.uk](http://www.monstershop.co.uk)**

---