

# KUKOO DOUBLE TIER OVERSHELF

24901

INSTRUCTION MANUAL

[www.monstershop.co.uk](http://www.monstershop.co.uk)



# SPECIFICATION

## PRODUCT DESCRIPTION

Thank you for purchasing this KuKoo Double Tier Over-shelf unit. With a whopping 100KG per shelf, this heavy-duty unit allows you to add extra room to any workspace and get your kitchen, café or restaurant organised.

The shelf is made from stainless steel, which means that cleaning up spills will be effortless! It is also resistant to corrosion and easy to secure to the surface of your bench – you'll be ready for your customers in a jiffy!

This item is designed as the perfect addition to our range of catering benches if you need that extra bit of storage space.

## PRODUCT SPECIFICS

<b>MATERIAL:</b>	304 Stainless Steel
<b>DIMENSIONS PER SHELF:</b>	180 (L) x 30 (W) x 3 (H) cm
<b>DIMENSIONS FULLY ASSEMBLED:</b>	180 (L) x 30 (W) x 75 (H) cm
<b>NET WEIGHT:</b>	14.1KG
<b>GROSS WEIGHT:</b>	15.6KG

## ITEM CONTENTS

- 2 x Stainless Steel Shelves
- 4 x Metal Rods
- 4 x Ferrule Locking Screws
- 4 x Tapping Screws

Monster Group UK Limited's liability will be limited to the commercial value of the product only.

# SPECIFICATION

## PRODUCT FEATURES

- A. Shelf 1
- B. Shelf 2
- C. Support Feet
- D. Metal Rods

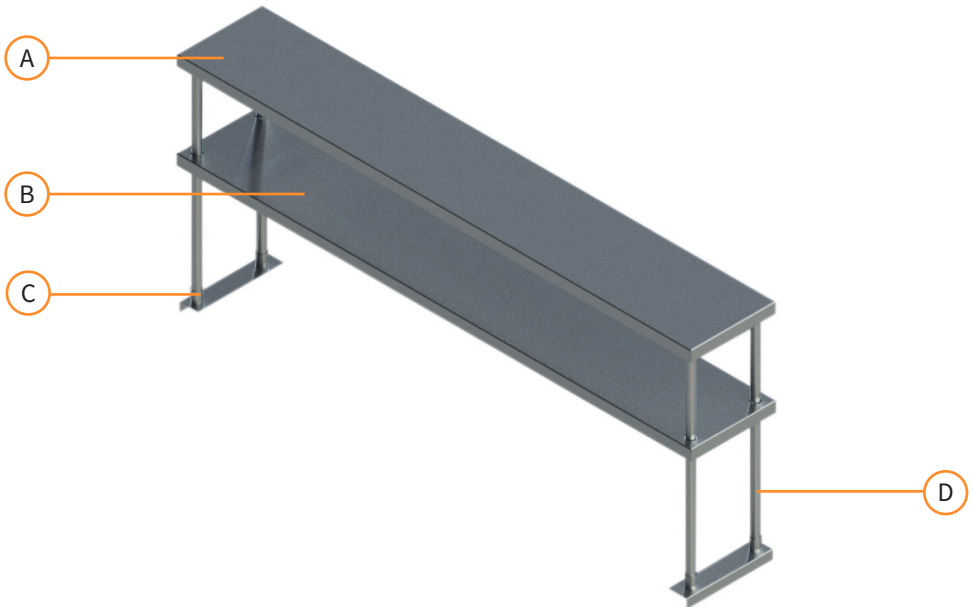

# SAFETY ADVICE

## SAFE WORKING PRACTICE

Please read through the safe working practice to ensure prevention of injury or damage to the device.

Keep the KuKoo Stainless Steel Catering Bench clean to prolong working life.

Do not use this product for anything other than its intended purposes.

Ensure you have read and fully understood the instruction manual and safety advice before using this product.

Do not allow children to touch this product.

Do not sit, stand or lean on this product.

Ensure this product is fitted correctly.

We recommend that this product is assembled by two people.

Keep body parts clear of pinch points when assembling or disassembling this product.

Use this product on an even surface.

Do not exceed the stated weight.

Do not use this product upside down.

Ensure that this product is the correct dimension for the bench it is to be fitted on.

Be aware of any sharp edges on this product.

# USER GUIDE

## ASSEMBLY INSTRUCTIONS

### Step One:

To begin assembling the over-shelf, place the top shelf flat (Part. A) on the ground so that the underside is facing upwards. Insert the 4 metal rods (Part. D) into these holes and press down to secure.

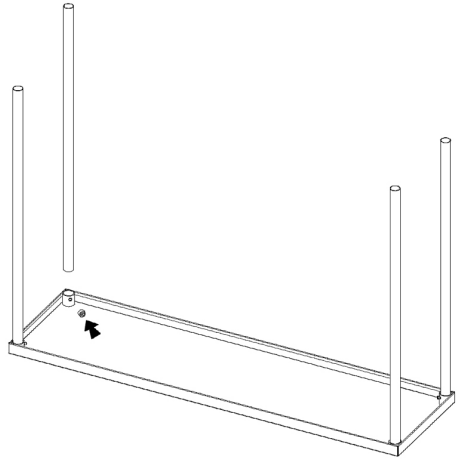

Diagram. 1

### Step Two:

To attach the second shelf layer (Part. B), keep the top shelf flat on the ground and line up the second shelf against all the rods. Make sure that the underside is facing upwards. Slide the second shelf down until it is halfway down the metal rods and secure each side into place with a ferrule locking screw.

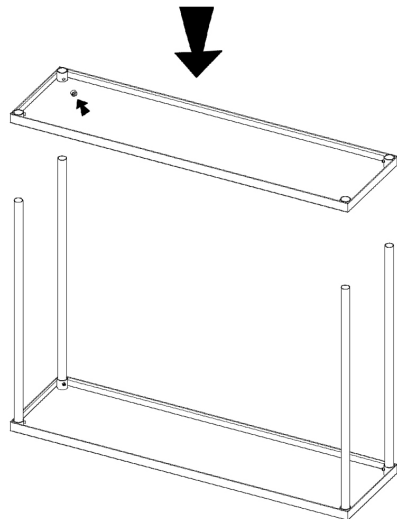

Diagram. 2

# USER GUIDE

## ASSEMBLY INSTRUCTIONS

### Step Three:

To attach the support feet (Part. C) onto the over-shelf, slide these onto the end of the metal rods and press down to secure into place.

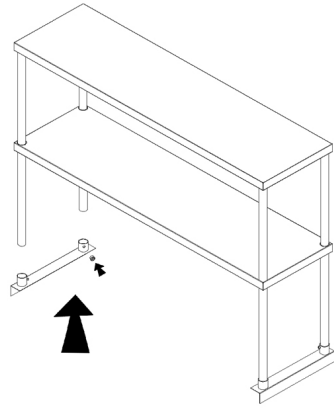

Diagram. 3

### Step Four:

To attach the over-shelf to your KuKoo Catering Bench, place the shelf on the surface of the bench, ensuring that the pre-drilled holes on the support feet are resting on the outer sides of the bench. Insert tapping screws into these to secure the shelf into place.

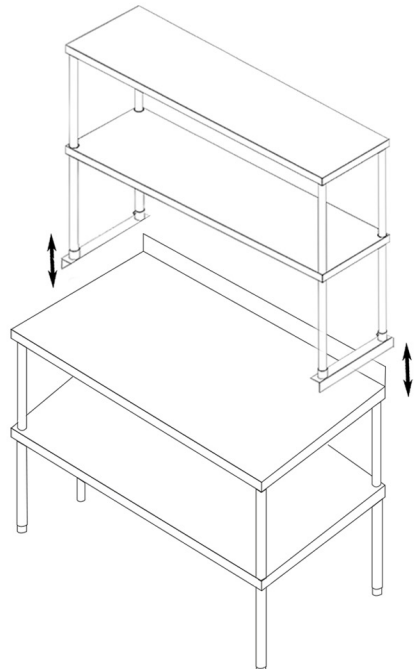

Diagram. 4

# TROUBLESHOOTING

## RESOLUTION GUIDE

### WHAT DO I DO IF THERE ARE MISSING PARTS FROM MY ORDER?

If there appears to be any part missing from your order, contact our friendly and helpful Customer Support Team within 7 days of receipt.

**FOR ALL OTHER ISSUES, PLEASE CONTACT OUR  
CUSTOMER SUPPORT TEAM.**

Monster Group (UK) is one of the UK's fastest growing online retailers. We supply a diverse range of products which offer exceptional value for money. We strive to provide the best possible customer experience with free UK delivery across all our products and a Monster Guarantee for 100% satisfaction.

For information regarding this device or other products from our Monster divisions please contact Sales.

#### SALES

TEL: 01347 878 888

EMAIL: hello@monstershop.co.uk

For queries about this device, warranty, returns or reporting faults please contact Support.

#### SUPPORT

TEL: 01347 878 887

EMAIL: help@monstershop.co.uk

Pour plus d'informations concernant cet appareil ou d'autres produits de nos divisions de Monster veuillez utiliser les détails suivants ci-dessous.

#### DÉPARTEMENT COMMERCIAL

TEL: 01347 878 888

EMAIL: bonjour@monstershop.eu

Pour les interrogations concernant cet appareil, la garantie, les retours ou les défauts de déclaration veuillez utiliser les détails suivants ci-dessous.

#### DÉPARTEMENT DE SOUTIEN

TEL: 01347 878 887

EMAIL: help@monstershop.co.uk

Para información sobre este dispositivo u otros productos de nuestras divisiones de Monster por favor use los siguientes detalles.

#### DEPARTAMENTO DE VENTAS

TEL: 01347 878 888

EMAIL: hola@monstershop.eu

Para consultas sobre este dispositivo, la garantía, devoluciones o denuncias de fallos por favor use los siguientes detalles.

#### DEPARTAMENTO DE SOPORTE

TEL: 01347 878 887

EMAIL: help@monstershop.co.uk

Für Informationen bezüglich dieses Geräts oder anderer Produkte aus unserer Monster-Abteilung, benutzen sie die folgenden unten aufgeführten Angaben.

#### VERKAUFABTEILUNG

TEL: 01347 878 888

EMAIL: hallo@monstershop.eu

Für Fragen über dieses Gerät, die Garantie, Rückgaben oder bei Störungen, benutzen sie die folgenden unten aufgeführten Angaben.

#### SUPPORT-ABTEILUNG

TEL: 01347 878 887

EMAIL: help@monstershop.co.uk

Per informazioni riguardanti questo dispositivo o altri prodotti dalle categorie Monster utilizzare i dettagli sotto riportati.

#### DIPARTIMENTO VENDITE

TEL: 01347 878 888

EMAIL: ciao@monstershop.eu

Per domande riguardo dispositivo, garanzia, reso o per riferire di guasti, utilizzare i dettagli sotto riportati.

#### DIPARTIMENTO SUPPORTO

TEL: 01347 878 887

EMAIL: help@monstershop.co.uk

Monster House, Alan Farnaby Way,  
Sheriff Hutton Industrial Estate,  
Sheriff Hutton, York, YO60 6PG  
[www.monstershop.co.uk](http://www.monstershop.co.uk)



 Try **Monster**. Buy **Monster**. Be **Monster**. 