

3m x 2m x 2m

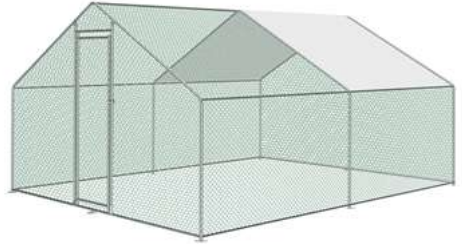

3m x 4m x 2m

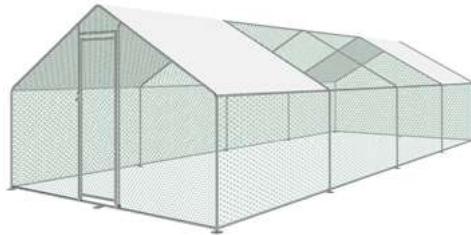

3m x 8m x 2m

3M METAL CHICKEN RUN

25814 / 25815 / 25947

INSTRUCTION MANUAL

www.monstershop.co.uk



SPECIFICATION

PRODUCT DESCRIPTION

This sturdy chicken run is perfect as an open run exercise area for your chickens. Your animals will not only get plenty of exercise in the enclosure, but, thanks to the UV-resistant and waterproof sunshade, also enjoy a soothing shade.

Due to its galvanized bars and PVC-coated chicken wire, the cage is durable and built to last. Assembly is easy and the run is large enough to house a coop. A lockable latch system ensures more safety.

Please refer to and read the Safe Working Practice to ensure prevention of injury or damage to the chicken run before starting.

PRODUCT SPECIFICS











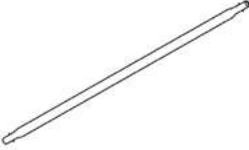



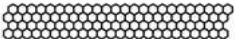

- 25814 - 3m x 2m x 2m
- 25815 - 3m x 4m x 2m
- 25947 - 3m x 8m x 2m
- 30mm x 40mm PVC-coated chicken wire
- 25mm galvanised steel tubing
- Electroplated steel feet

PRODUCT FEATURES

- Stable and durable.
- Heavy Duty galvanised steel frame structure with a pitched roof.
- PVC coated hexagonal wire mesh to wrap around the structure.
- Outdoor weatherproof cover finished in grey with silver lined coating UV-resistant and waterproof sunshade (2 on 8m size).
- Easy assembly.
- Lockable latch.

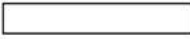
SPECIFICATION

ITEM CONTENTS

Part No.	Part Size	Part Picture	Part Quantity		
			3 x 2 x 2m	3 x 4 x 2m	3 x 8 x 2m
①	1410mm		4	4	4
②	1870mm		5	10	20
③	970mm		4	6	10
④	1480mm		4	6	10
⑤	450mm		2	2	2
⑥	540mm		1	1	1
A			6	6	6
B			0	3	9
C			4	4	4
D			0	2	6
E			2	2	2
⑦			1	1	1
⑧			1	1	1
⑨			1	1	1
F	chicken wire		1	1	1
G			1	1	1
H			2	2	2
I			3	3	3
J	roof cover		1	1	2
K			3	3	3
L			1	1	1
	cable ties		150	300	450
	pegs		6	8	12

SAFETY ADVICE

SAFE WORKING PRACTICE

Please read through the Safe Working Practice to ensure prevention of injury or damage to the chicken run.

Ensure you have read and fully understood the instruction manual and safety advice before using this product.

Ensure you have all the component parts on the list and familiarise yourself with each part before proceeding.

Do not use this product for anything other than its intended purposes.

Make sure the site selected for set-up will be clear of debris - this includes; sharp objects, sticks, stones, etc.

Care must be taken when fitting the wire mesh as the cut edges are very sharp.

Product to be assembled by more than two people.

Do not allow children to play in, on, or around this product.

Keep children and bystanders away while assembling this product.

Do not modify this product in any way. Unauthorized modification may impair the function and/or safety and could affect the life of the equipment.

To avoid risk of suffocation to animals or children dispose of the all packaging immediately.

Despite the chicken runs sturdy construction it may not be strong enough to keep out a determined predator. Chickens should be housed overnight in a secure coop.

TROUBLESHOOTING

RESOLUTION GUIDE

WHAT DO I DO IF THERE ARE MISSING PARTS FROM MY ORDER?

If there appears to be any part missing from your order, contact our friendly and helpful Customer Support Team within 7 days of receipt.

**FOR ALL OTHER ISSUES, PLEASE CONTACT OUR
CUSTOMER SUPPORT TEAM.**

USER GUIDE - 3m x 2m x 2m

ASSEMBLY INSTRUCTIONS

STEP 1

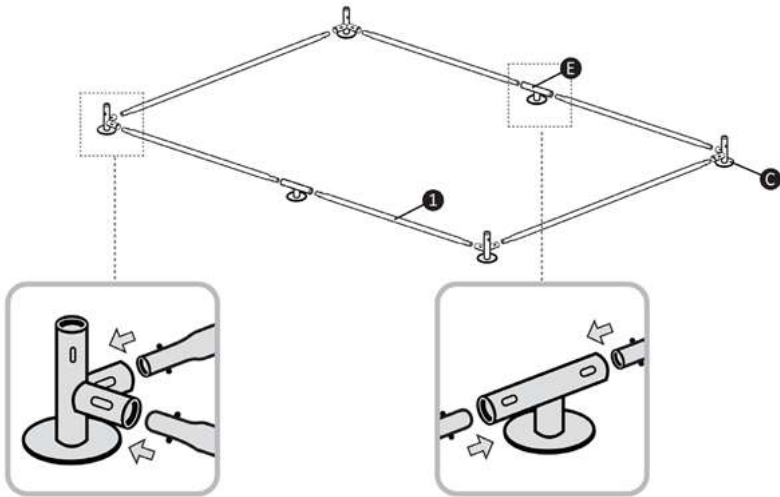

STEP 2

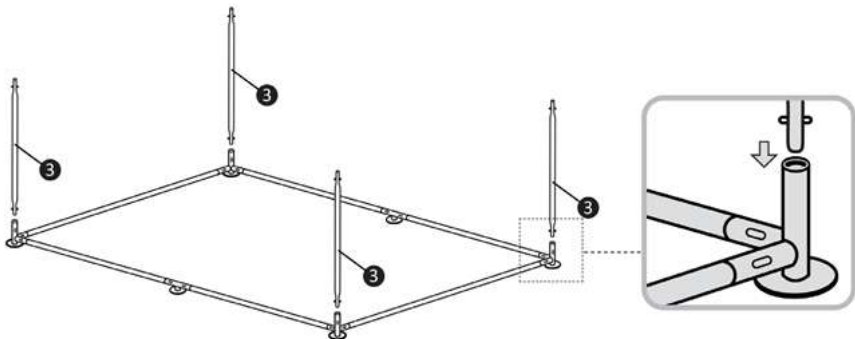

USER GUIDE - 3m x 2m x 2m

ASSEMBLY INSTRUCTIONS

STEP 3

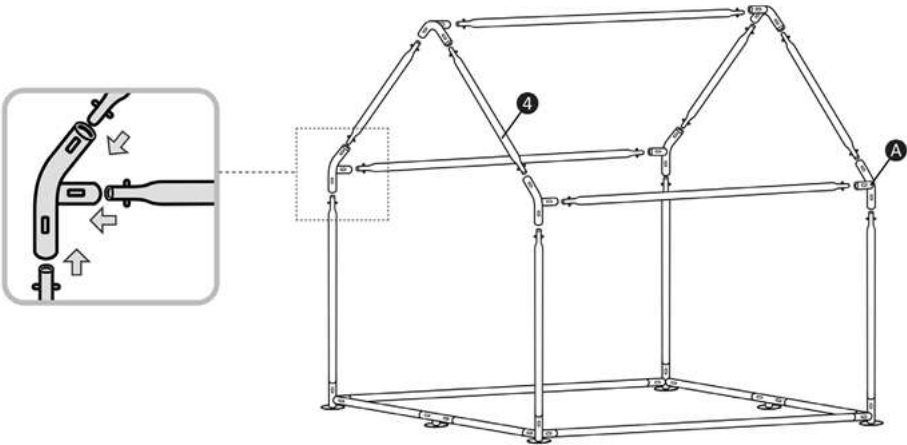

STEP 4

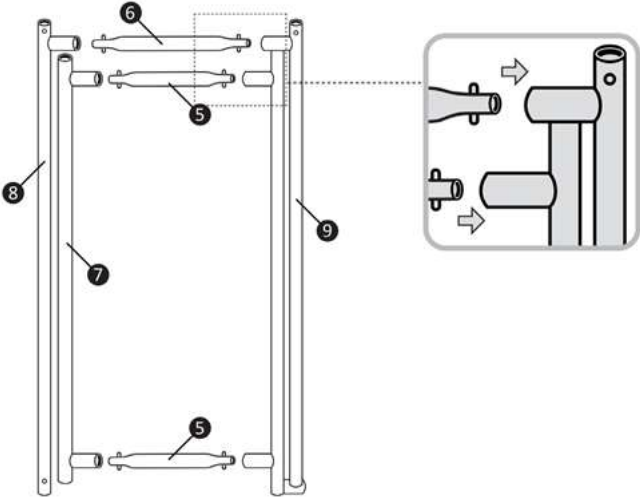

USER GUIDE - 3m x 2m x 2m

ASSEMBLY INSTRUCTIONS

STEP 5

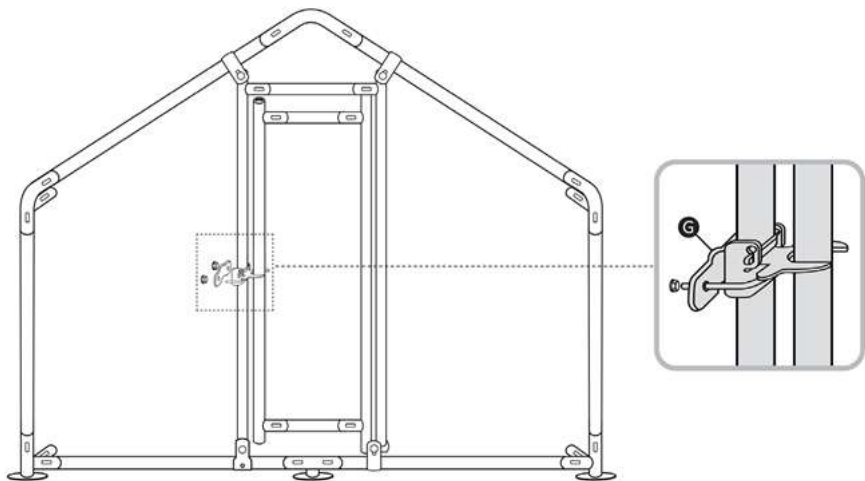
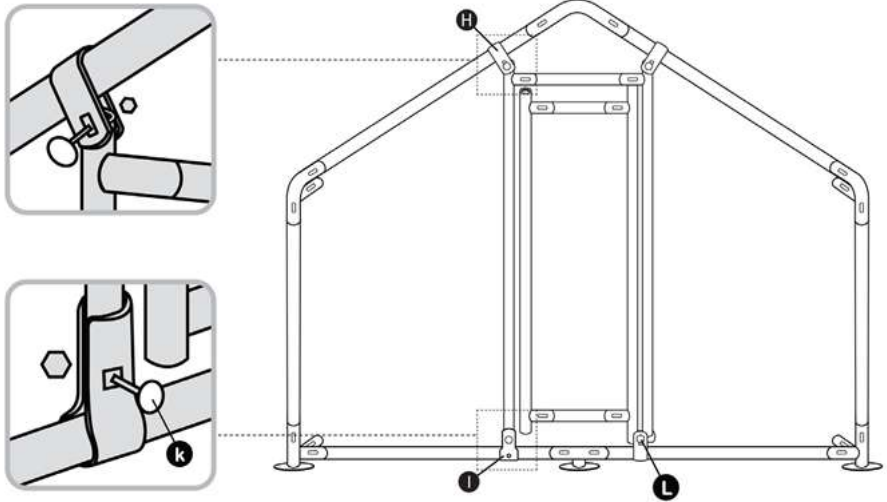

USER GUIDE - 3m x 2m x 2m

ASSEMBLY INSTRUCTIONS

STEP 6

Tie the hexagonal wire mesh to the bars as you wrap it around the structure.

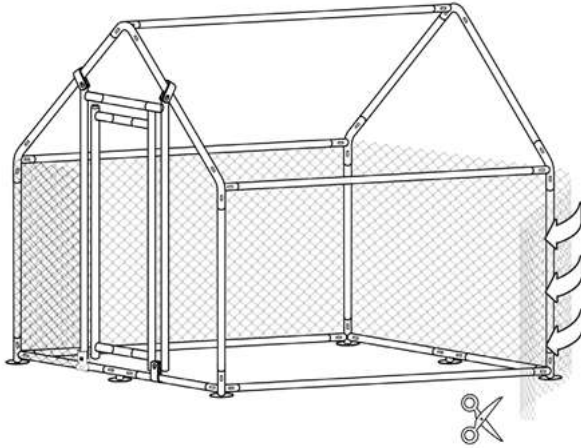

STEP 7

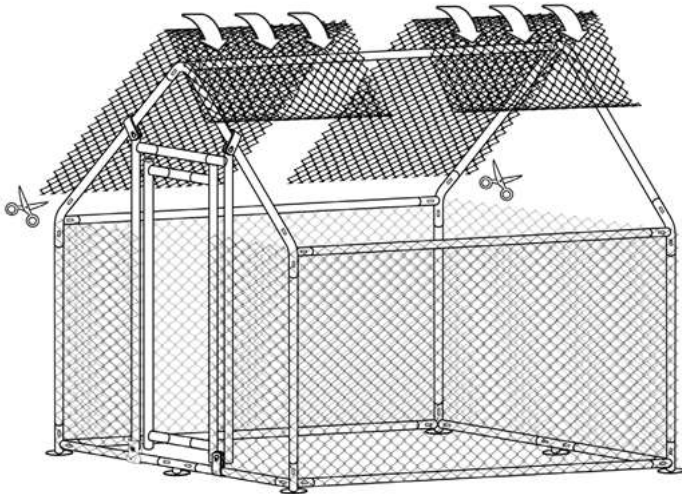

USER GUIDE - 3m x 2m x 2m

ASSEMBLY INSTRUCTIONS

STEP 8

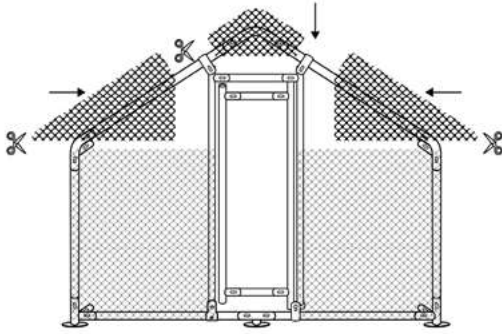

(Front)

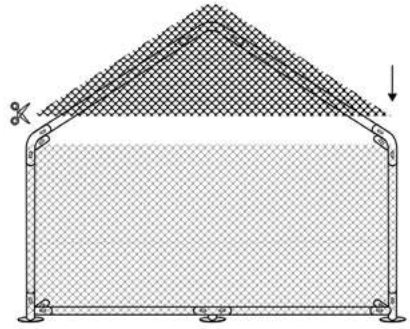

(Back)

STEP 9

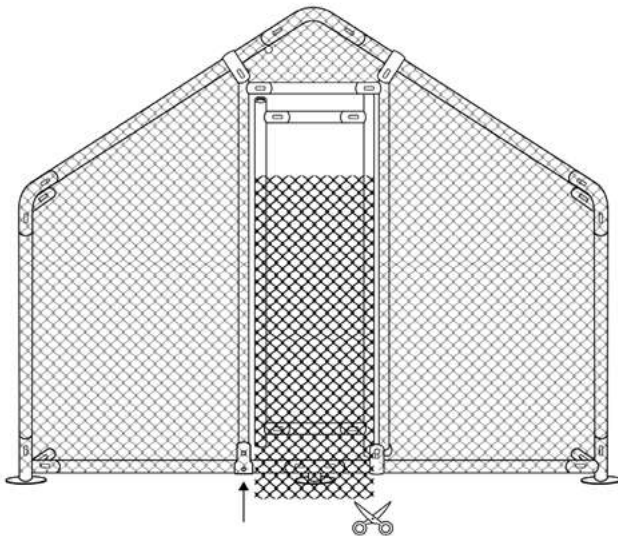

USER GUIDE - 3m x 4m x 2m

ASSEMBLY INSTRUCTIONS

STEP 1

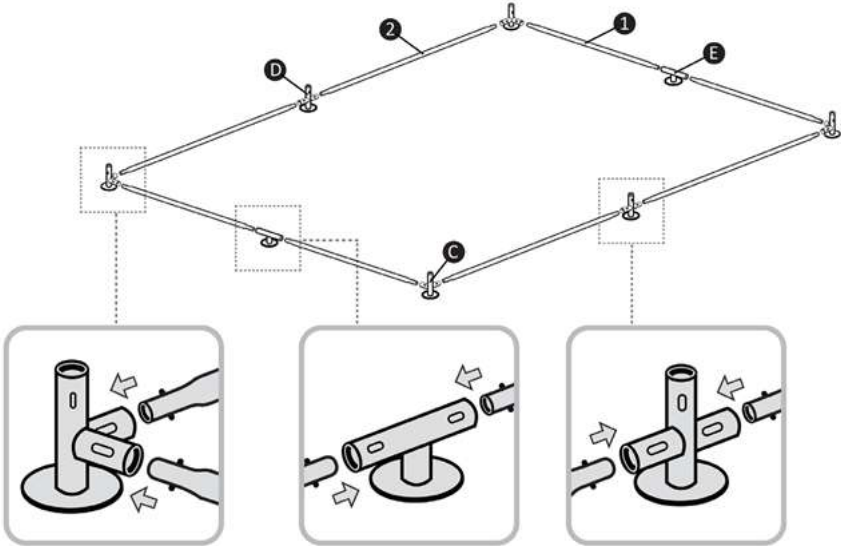

STEP 2

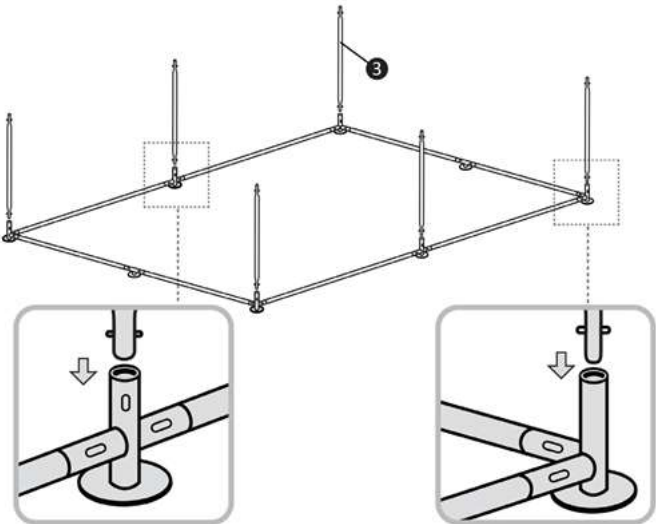

USER GUIDE - 3m x 4m x 2m

ASSEMBLY INSTRUCTIONS

STEP 3

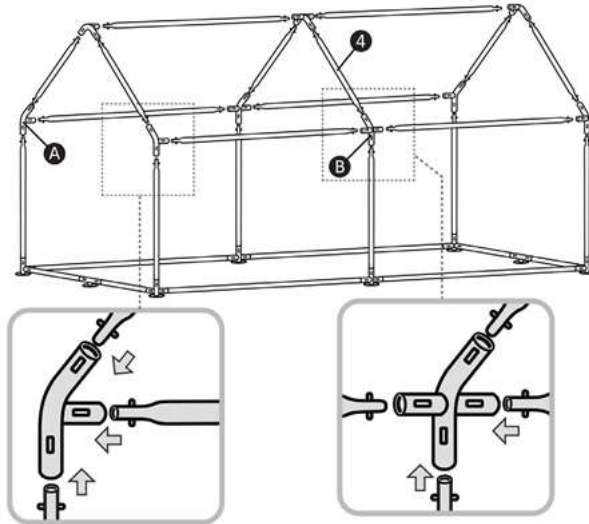

STEP 4

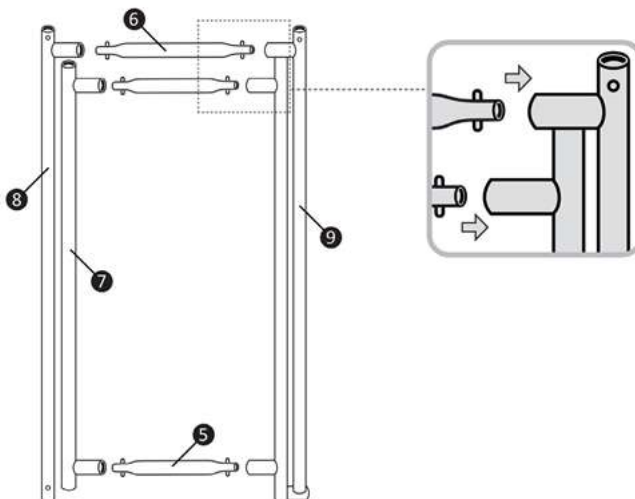

USER GUIDE - 3m x 4m x 2m

ASSEMBLY INSTRUCTIONS

STEP 5

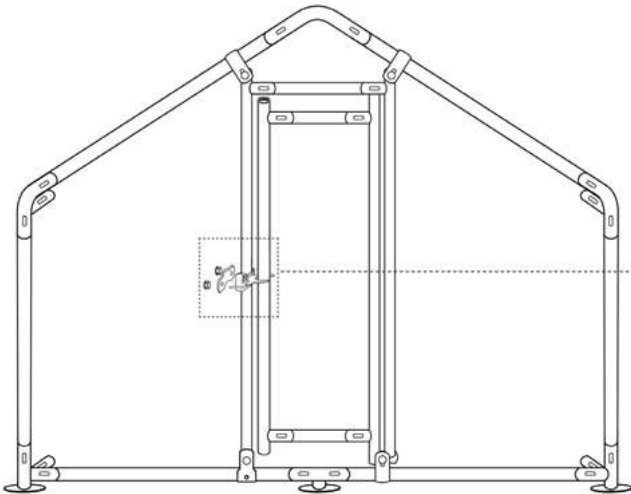
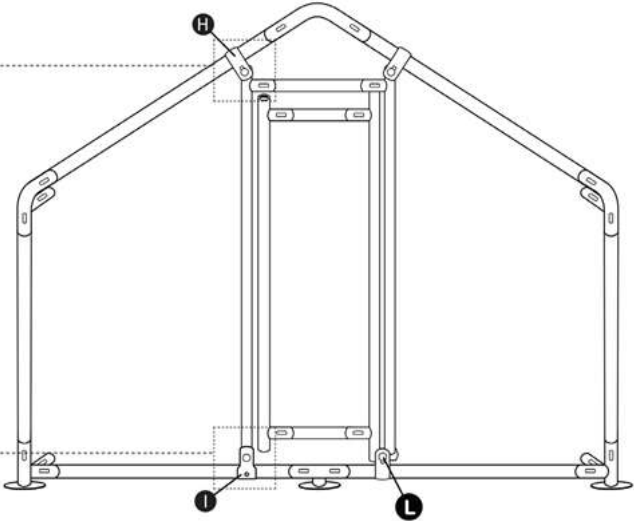

USER GUIDE - 3m x 4m x 2m

ASSEMBLY INSTRUCTIONS

STEP 6

Tie the hexagonal wire mesh to the bars as you wrap it around the structure.

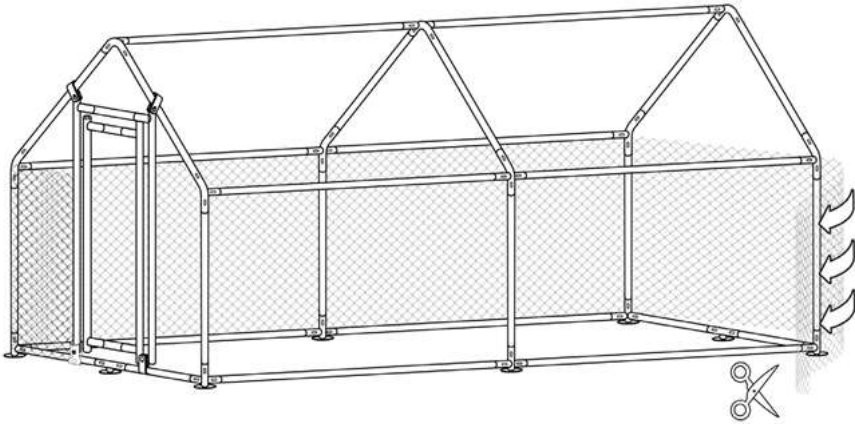

STEP 7

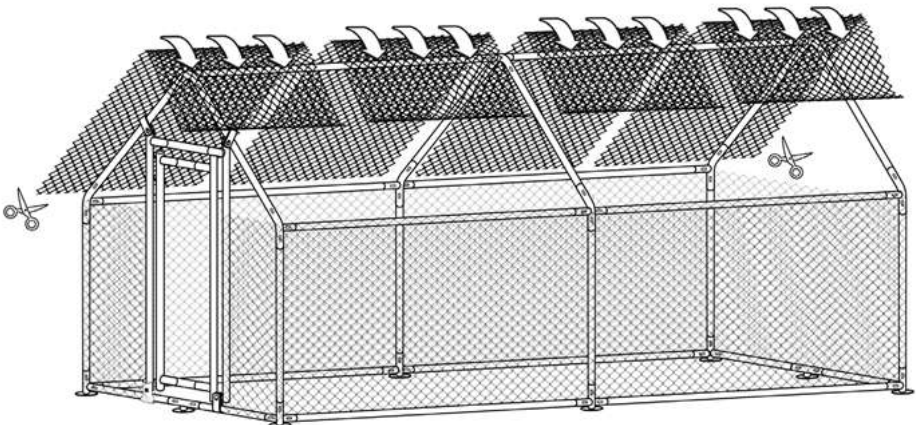

USER GUIDE - 3m x 4m x 2m

ASSEMBLY INSTRUCTIONS

STEP 8

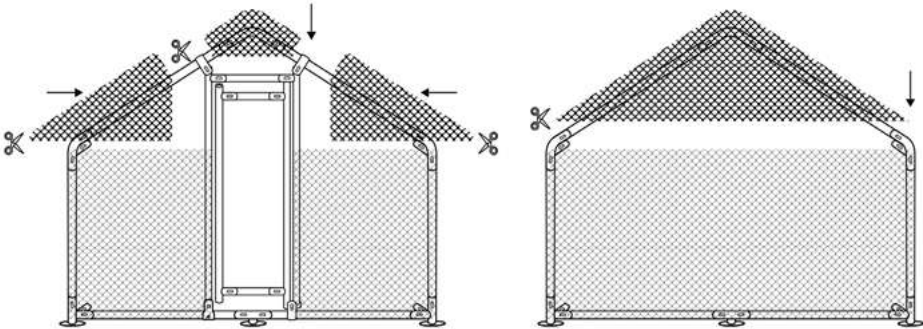

(Front)

(Back)

STEP 9

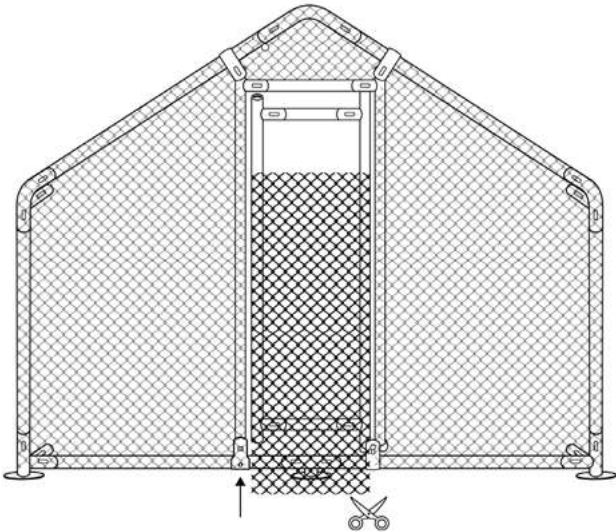

USER GUIDE - 3m x 8m x 2m

ASSEMBLY INSTRUCTIONS

STEP 1

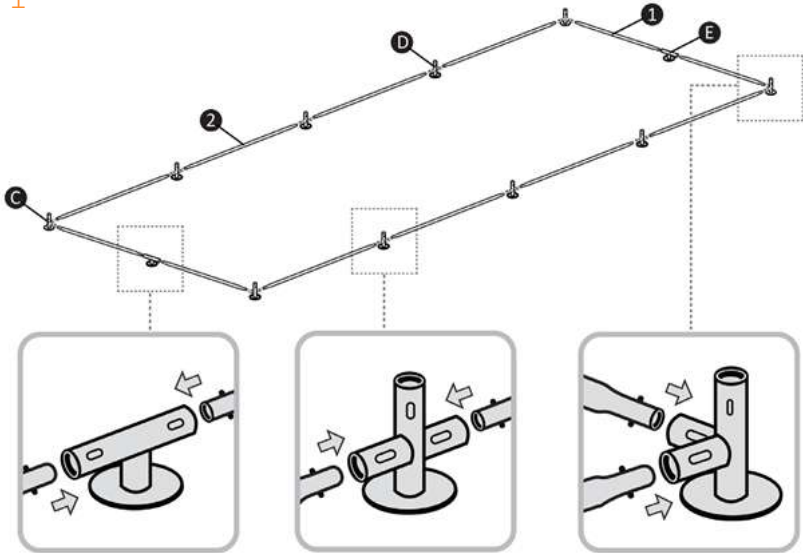

STEP 2

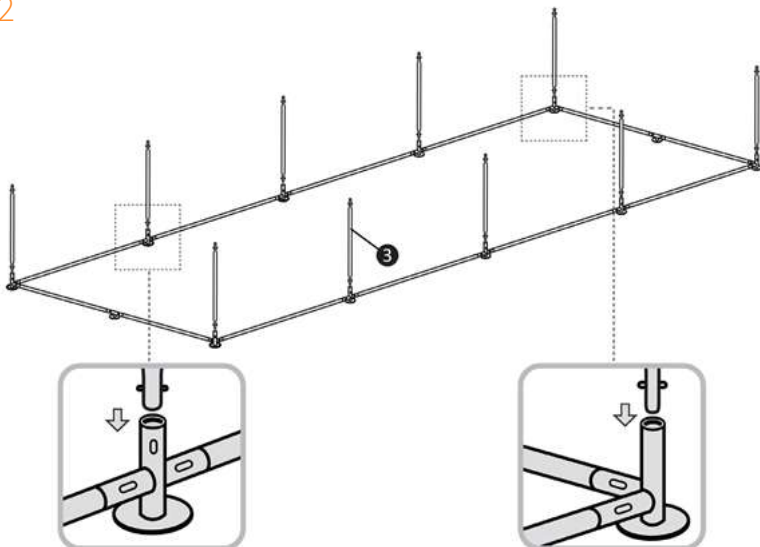

USER GUIDE - 3m x 8m x 2m

ASSEMBLY INSTRUCTIONS

STEP 3

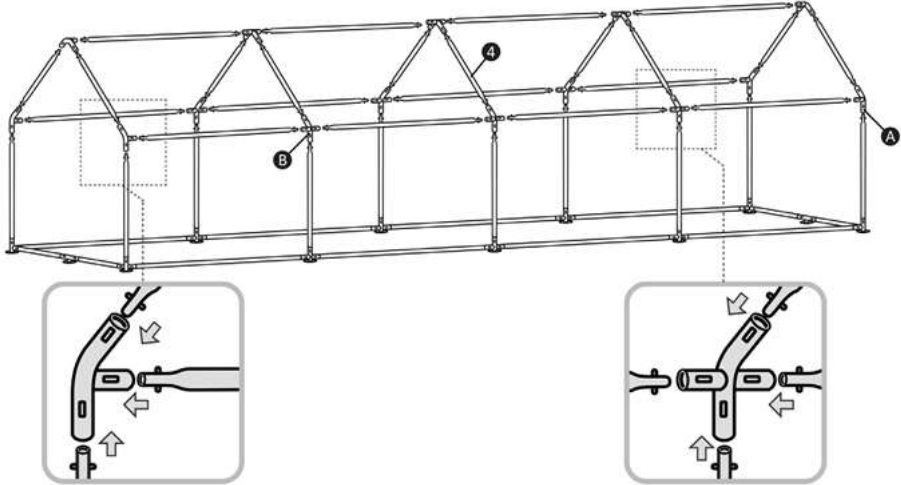

STEP 4

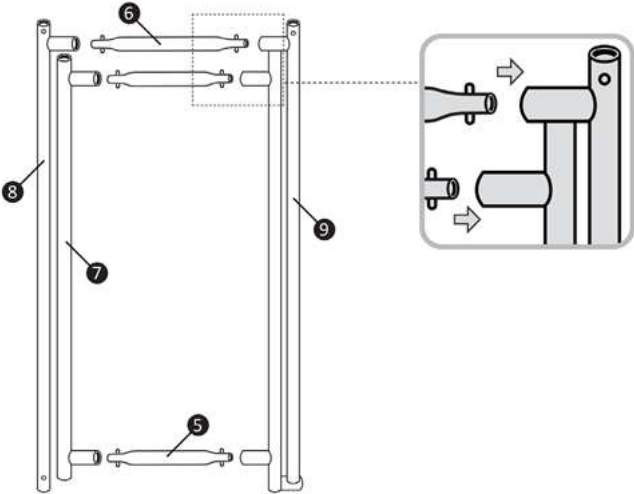

USER GUIDE - 3m x 8m x 2m

ASSEMBLY INSTRUCTIONS

STEP 5

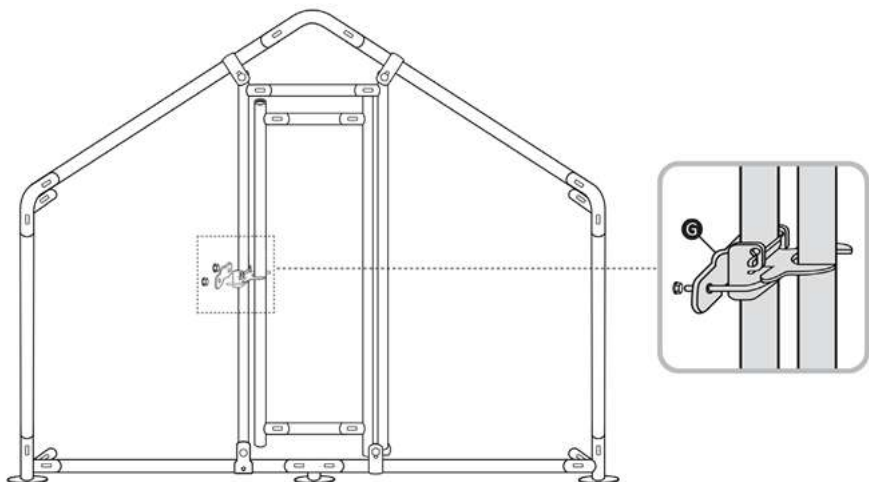
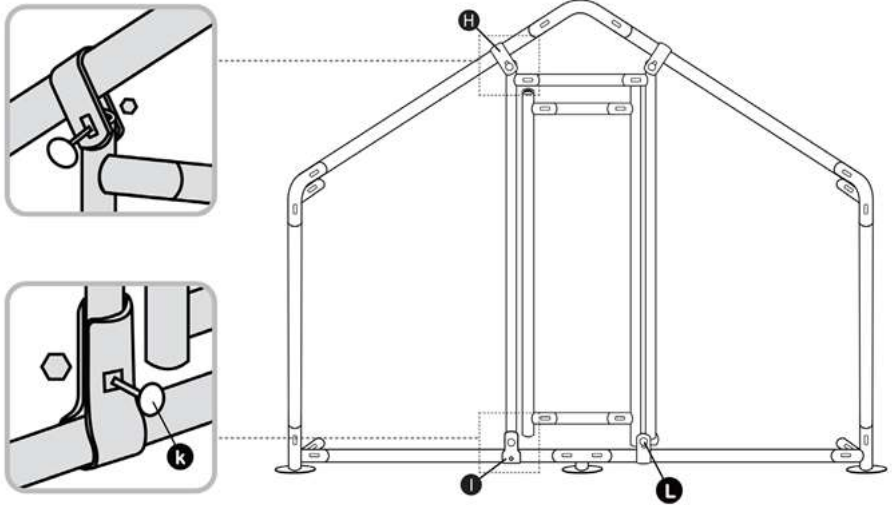

USER GUIDE - 3m x 8m x 2m

ASSEMBLY INSTRUCTIONS

STEP 6

Tie the hexagonal wire mesh to the bars as you wrap it around the structure.

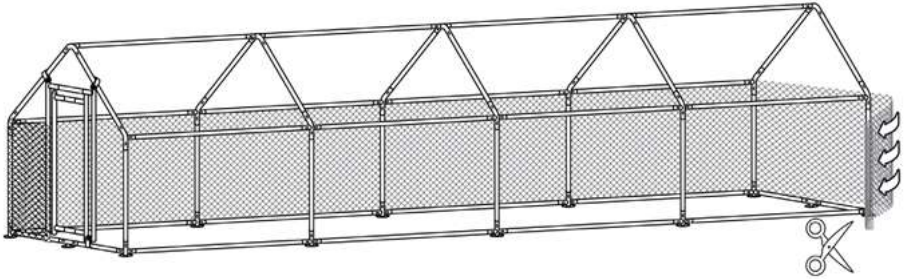

STEP 7

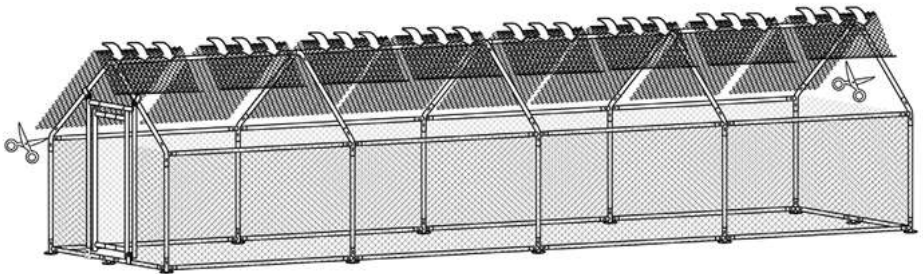

USER GUIDE - 3m x 8m x 2m

ASSEMBLY INSTRUCTIONS

STEP 8

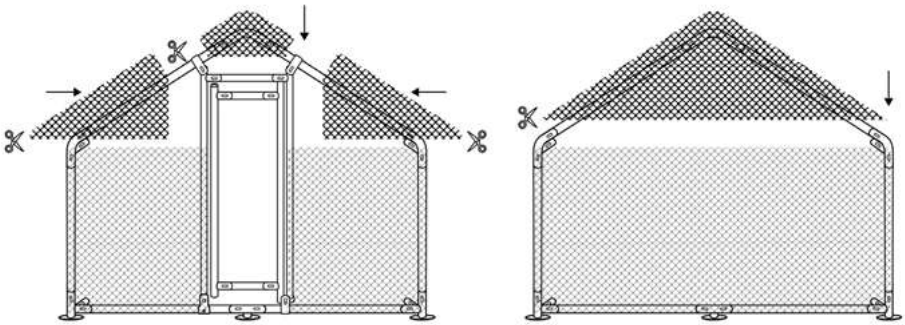

(Front)

(Back)

STEP 9

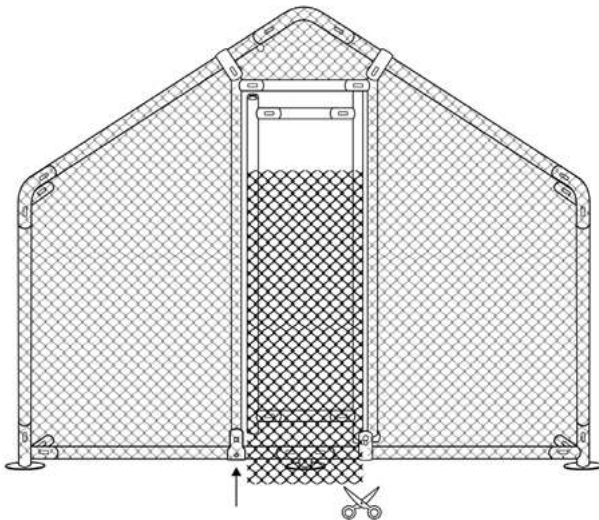

CONSEILS DE SÉCURITÉ

PRATIQUE DE TRAVAIL SÉCURITAIRE

Veillez lire attentivement les consignes de sécurité afin d'éviter toute blessure ou tout endommagement de l'appareil.

Assurez que vous avez lu et compris les instructions et les consignes de sécurité avant d'utilisation de ce produit.

Assurez que vous avez tous les composants sur la liste et familiarisez-vous avec chaque composant avant de procéder.

Ne pas utiliser ce produit à des fins autres que celles prévues.

Assurez-vous que l'endroit choisi est dégagé de débris – ceci inclus : objets coupants, bâtons, pierres, etc.

Prenez soin lorsque vous installer le grillage métallique car les bords sont très coupants.

Le produit doit être assemblé par deux personnes ou plus.

Ne laissez pas des enfants jouer sur, à l'intérieur ou au alentours de ce produit.

Garder à l'écart des enfants et des passants lors de l'assemblage de ce produit.

N'apportez pas de modification à ce produit. Toute modification non autorisée peut nuire la fonction du produit et peut affecter la durabilité de l'équipement.

Pour éviter tout risque d'étouffement pour animaux ou enfants veuillez disposer de tout déchets immédiatement.

Malgré la construction robuste de ce poulailler, elle n'est peut-être pas assez robuste d'empêcher l'entrée d'un prédateur déterminé. Les poules doivent être abriter dans un poulailler sécurisé pendant la nuit.

Veillez noter: Le grillage métallique hexagonal doit être attaché à la barre lorsque vous l'emballer autour de la structure.

SPÉCIFICATIONS

SPÉCIFICATIONS DE PRODUIT

- 25814 - 3m x 2m x 2m
- 25815 - 3m x 4m x 2m
- 25947 - 3m x 8m x 2m
- 30mm x 40mm grillage PVC enduit
- 25mm tuyau métallique galvanisé
- Pieds en acier électrodéposé

CARACTÉRISTIQUES DU PRODUIT

- Stable et durable.
- Structure en acier galvanisé robuste avec toiture incline.
- Grillage métallique PVC enduit pour envelopper la structure.
- Housse imperméable avec finition en gris avec revêtement UV-résistant et imperméable (taille 2 sur 8 m).
- Assemblage facile.
- Porte verrouillable.

DÉPANNAGE

GUIDE DE RÉOLUTION

IL MANQUE DES PIÈCES À MA COMMANDE.

S'il semble y avoir une pièce manquante dans votre colis, contactez notre Service technique via les détails sur la page "Contactez-nous".

POUR TOUT AUTRE DEMANDE, VEUILLEZ CONTACTER NOTRE ÉQUIPE DU SERVICE CLIENT



SICHERHEITSHINWEISE



SICHERES ARBEITEN

Bitte lesen Sie sich die Sicherheitshinweise durch, um Verletzungen oder Schäden am Hühnerauslauf zu vermeiden.

Stellen Sie sicher, dass Sie die Bedienungsanleitung und die Sicherheitshinweise gelesen und vollständig verstanden haben, bevor Sie dieses Produkt verwenden.

Stellen Sie sicher, dass alle Komponenten in der Liste enthalten sind und machen Sie sich mit den einzelnen Teilen vertraut, bevor Sie fortfahren.

Verwenden Sie dieses Produkt nur für den vorgesehenen Zweck.

Stellen Sie sicher, dass der für den Aufbau ausgewählte Standort frei von Trümmern ist - dies schließt Folgendes ein: scharfe Gegenstände, Stöcke, Steine usw.

Bei der Montage des Drahtgeflechts ist Vorsicht geboten, da die Schnittkanten sehr scharf sind.

Das Produkt sollte von mehr als zwei Personen zusammengebaut werden.

Lassen Sie Kinder nicht in, auf oder in der Nähe dieses Produkts spielen.

Halten Sie während des Zusammenbaus Kinder und umstehende Personen fern.

Verändern Sie dieses Produkt in keiner Weise. Nicht autorisierte Änderungen können die Funktion und / oder Sicherheit beeinträchtigen und die Lebensdauer des Geräts beeinträchtigen.

Zur Vermeidung von Erstickengefahr für Tiere oder Kinder ist die gesamte Verpackung sofort zu entsorgen.

Trotz der robusten Konstruktion des Hühnerauslaufs ist dieser möglicherweise nicht stark genug, um ein willensstarkes Raubtier fernzuhalten. Hühner sollten über Nacht in einem sicheren Stall untergebracht werden.

Bitte beachten Sie: Das sechseckige Drahtgeflecht sollte an den Stangen befestigt werden, während Sie es um das Gebilde wickeln.

SPEZIFIKATIONEN

PRODUKTSPEZIFIKATIONEN

- 25814 - 3m x 2m x 2m
- 25815 - 3m x 4m x 2m
- 25947 - 3m x 8m x 2m
- 30mm x 40mm PVC-beschichteter Hühnerdraht
- 25mm verzinktes Stahlrohr
- Elektroplattierte Stahlfüße

PRODUKTMERKMALE

- Stabil und langlebig.
- Strapazierfähige verzinkte Stahlrahmenkonstruktion mit geneigtem Dach.
- PVC-beschichtetes Drahtgeflecht zum Umwickeln der Struktur.
- Wetterschutzhülle für den Außenbereich in Grau mit silberbeschichteter UV-beständiger und wasserdichter Sonnenblende (Größe 2 auf 8 m).
- Einfacher Zusammenbau.
- Verschließbarer Riegel.

PROBLEMLÖSUNG

FEHLERBEHEBUNG

WAS TUN, WENN TEILE AUS MEINER BESTELLUNG FEHLEN?

Sollte ein Teil Ihrer Bestellung fehlen, wenden Sie sich innerhalb von 7 Tagen nach Erhalt der Ware an unser freundliches und hilfsbereites Kundendienstteam.

**FÜR ALLE ANDEREN FRAGEN WENDEN SIE SICH BITTE AN
UNSER KUNDENDIENSTEAM.**



CONSEJOS DE SEGURIDAD



PRÁCTICA SEGURA DE MANEJO

Lea las Prácticas de Trabajo Seguras para garantizar la prevención de lesiones o daños al gallinero.

Asegúrese de haber leído y entendido completamente el manual de instrucciones y los consejos de seguridad antes de usar este producto.

Asegúrese de tener todos los componentes de la lista y familiarícese con cada parte antes de continuar.

No utilice este producto para ningún otro fin que no sea el previsto.

Asegúrese de que el sitio seleccionado para la instalación esté libre de escombros, esto incluye; objetos afilados, palos, piedras, etc.

Se debe tener cuidado al colocar la malla de alambre ya que los bordes cortados son muy afilados.

Producto para ser ensamblado por más de dos personas.

No permita que los niños jueguen dentro, sobre o alrededor de este producto.

Mantenga alejados a los niños y espectadores mientras ensambla este producto.

No modifique este producto de ninguna manera. La modificación no autorizada puede afectar la función y / o seguridad y podría afectar la vida útil del equipo.

Para evitar el riesgo de asfixia a animales o niños, deseche todos los envases de inmediato.

A pesar de que el gallinero tiene una construcción resistente, puede que no sea lo suficientemente fuerte como para mantener alejado a un depredador determinado. Los pollos deben alojarse durante la noche en un gallinero seguro.

Tenga en cuenta: la malla de alambre hexagonal debe estar atada a las barras a medida que la envuelve alrededor de la estructura.

Tenga en cuenta: la malla de alambre hexagonal debe estar atada a las barras a medida que la envuelve alrededor de la estructura.

ESPECIFICACIONES

ESPECIFICACIONES DEL PRODUCTO

- 25814 - 3m x 2m x 2m
- 25815 - 3m x 4m x 2m
- 25947 - 3m x 8m x 2m
- 30 mm x 40 mm de alambre de pollo recubierto de PVC
- Tubo de acero galvanizado de 25 mm
- Pies de acero electrochapado

CARACTERÍSTICAS DEL PRODUCTO

- Estable y duradero.
- Estructura de estructura de acero galvanizado de alta resistencia con techo inclinado.
- Malla de alambre hexagonal recubierta de PVC para envolver la estructura.
- Cubierta exterior resistente a la intemperie acabada en gris con revestimiento forrado de plata Sombrilla resistente a los rayos UV e impermeable (tamaño 2 en 8 m).
- Fácil montaje.
- Pestillo bloqueable.

SOLUCIÓN DE PROBLEMAS

GUÍA DE RESOLUCIÓN

¿QUÉ HAGO SI HAY PIEZAS FALTANTES DE MI PEDIDO?

Si parece que falta alguna pieza en su pedido, comuníquese con nuestro amable y servicial Equipo de Atención al Cliente dentro de los 7 días posteriores a la recepción.

PARA CUALQUIER OTRA CUESTIÓN, NO DUDE EN CONTACTAR CON NUESTRO EQUIPO DE ATENCIÓN AL CLIENTE.

CONSIGLI DI SICUREZZA

PROCEDURA DI LAVORO SICURO

Prego leggere la procedura di sicurezza per prevenire lesioni alla persona o danni al pollaio.

Assicurarsi di aver letto e compreso il manuale di istruzioni e l'avviso di sicurezza prima di utilizzare il prodotto.

Assicurarsi di aver tutti i componenti sulla lista e di familiarizzare con ogni parte prima di procedere.

Non usare questo prodotto per scopi diversi da quelli previsti.

Assicurarsi che il sito selezionato per l'installazione sia sgombro da rottami inclusi: oggetti taglienti, rami, pietre ecc...

Fare attenzione nel installare la rete in quanto i bordi sono molto taglienti.

Il prodotto richiede l'assemblaggio da almeno due persone.

Non permettere a bambini di giocare con o in questo prodotto.

Tenere lontano dalla portata di bambini e passanti durante l'assemblaggio.

Non modificare il prodotto in nessun modo. Modifiche non autorizzate potrebbero compromettere la funzione e la sicurezza del prodotto e potrebbero intaccare la durevolezza dell'oggetto.

Per evitare il rischio di soffocamento per bambini o animali, disfarsi dell'imballaggio immediatamente.

Nonostante la sua costruzione robusta, il pollaio potrebbe non essere in grado di tenere lontano i predatori più grandi. Il pollame dovrebbe essere ospitato in un luogo sicuro durante la notte.

Prego notare: la rete esagonale dovrebbe essere legata al telaio del pollaio durante lo dispiegamento attorno alla struttura.

SPECIFICHE

SPECIFICHE PRODOTTO

- 25814 - 3m x 2m x 2m
- 25815 - 3m x 4m x 2m
- 25947 - 3m x 8m x 2m
- 30mm x 40mm rete per pollame ricoperta in PVC
- 25mm pali in acciaio zincato
- Piedi in acciaio elettroplaccato

CARATTERISTICHE DEL PRODOTTO

- Stabile e durevole.
- Struttura in telaio in robusto acciaio zincato.
- Rete esagonale ricoperta con PVC da avvolgere attorno alla struttura.
- Copertura per esterno impermeabile rifinita in grigio con fodera argentata resistente UV (2 per i pollai da 8m)
- Facile da assemblare
- Porta bloccabile

RISOLUZIONE PROBLEMI

GUIDA ALLA RISOLUZIONE

COSA FARE SE MANCASSERO PARTI NEL MIO ORDINE?

Se apparisse che vi siano parti mancanti nel vostro ordine, contattare il nostro amichevole servizio clienti entro 7 giorni dalla ricezione.

PER TUTTE LE ALTRE QUESTIONI, CONTATTARE IL NOSTRO TEAM DI SERVIZIO CLIENTI.

VEILIGHEIDSADVIES

VEILIGE WERKMETHODEN

Gelieve de Safe Working Practice goed door te lezen om persoonlijk letsel of schade aan de kippenren te voorkomen.

Zorg dat u de handleiding en het veiligheidsblad gelezen en begrepen heeft voordat u met het product aan de slag gaat.

Zorg dat alle onderdelen volgens de meegeleverde lijst aanwezig zijn en herken de materialen voor deze in elkaar te zetten.

Gebruik dit product niet anders dan waarvoor het bedoeld is.

Zorg dat de plek opgeruimd en vrij van rommel is – verwijder scherpe voorwerpen, stenen, stokken, etc.

Wees voorzichtig met de scherpe uiteinden van het gaas.

Monteer de kippenren met ten minste twee personen.

Houdt kinderen uit de buurt en laat ze niet in of op de ren spelen.

Houdt kinderen en omstanders uit te buurt tijdens montage.

Wijzig niets aan het product of ontwerp. Wijzigingen aan het product of de constructie kunnen nadelig uitpakken voor het gebruik van het product of de veiligheid en levensduur ervan.

Om inslikingsgevaar bij zowel kinderen als dieren te voorkomen ruim alle verpakkingsmaterialen meteen op.

Ondanks dat de kippenren een stevige constructie is, kan het gebeuren dat roofdieren de kippenren binnen dringen. Houdt de kippen daarom 's nachts binnen in een beveiligde ren.

Houd er rekening mee het zeshoekige gaas aan de balken te bevestigen nadat deze om de structuur gehuld is.

OMSCHRIJVING

PRODUCT SPECIFICATIES

- 25814 - 3m x 2m x 2m
- 25815 - 3m x 4m x 2m
- 25947 - 3m x 8m x 2m
- 30mm x 40mm Geplastificeerd kippengaas
- 25mm gegalvaniseerde stalen buizen
- Gegalvaniseerde stalen poten

PRODUCTEIGENSCHAPPEN

- Stabiel en duurzaam.
- Robuust gegalvaniseerd stalen frame met hellend dak.
- Geplastificeerd hexagonaal kippengaas om de kooiconstructie te omhullen.
- Waterdicht en Uv-bestendig dak in grijs met zilveren omrand waterdicht zonnescerm.
Afmetingen: 2x8m.
- Eenvoudig op te zetten.
- Afsluitbare vergrendeling.

VEEL VOORKOMENDE PROBLEMEN

OPLOSSINGSGIDS

WAT MOET IK DOEN WANNEER ONDERDELEN ONTBREKEN?

Wanneer u merkt dat een onderdeel ontbreekt, kunt u binnen 7 dagen na aankoop contact opnemen met onze vriendelijke en behulpzame klantendienst.

**NEEM VOOR ALLE ANDERE PROBLEMEN CONTACT OP MET
ONZE KLANTENSERVICE**



Monster Group (UK) is one of the UK's fastest growing online retailers. We supply a diverse range of products which offer exceptional value for money. We strive to provide the best possible customer experience with free UK delivery across all our products and a Monster Guarantee for 100% satisfaction.

For information regarding this device or other products from our Monster divisions please contact Sales.

SALES

TEL: 01347 878 888
EMAIL: hello@monstershop.co.uk

For queries about this device, warranty, returns or reporting faults please contact Support.

SUPPORT

TEL: 01347 878 887
EMAIL: help@monstershop.co.uk

Pour plus d'informations concernant cet appareil ou d'autres produits de nos divisions de Monster veuillez utiliser les détails suivants ci-dessous.

DÉPARTEMENT COMMERCIAL

TEL: 01347 878 888
EMAIL: bonjour@monstershop.eu

Pour les interrogations concernant cet appareil, la garantie, les retours ou les défauts de déclaration veuillez utiliser les détails suivants ci-dessous.

DÉPARTEMENT DE SOUTIEN

TEL: 01347 878 887
EMAIL: help@monstershop.co.uk

Para información sobre este dispositivo u otros productos de nuestras divisiones de Monster por favor use los siguientes detalles.

DEPARTAMENTO DE VENTAS

TEL: 01347 878 888
EMAIL: hola@monstershop.eu

Para consultas sobre este dispositivo, la garantía, devoluciones o denuncias de fallos por favor use los siguientes detalles.

DEPARTAMENTO DE SOPORTE

TEL: 01347 878 887
EMAIL: help@monstershop.co.uk

Für Informationen bezüglich dieses Geräts oder anderer Produkte aus unserer Monster-Abteilung, benutzen sie die folgenden unten aufgeführten Angaben.

VERKAUFABTEILUNG

TEL: 01347 878 888
EMAIL: hallo@monstershop.eu

Für Fragen über dieses Gerät, die Garantie, Rückgaben oder bei Störungen, benutzen sie die folgenden unten aufgeführten Angaben.

SUPPORT-ABTEILUNG

TEL: 01347 878 887
EMAIL: help@monstershop.co.uk

Per informazioni riguardanti questo dispositivo o altri prodotti dalle categorie Monster utilizzare i dettagli sotto riportati.

DIPARTIMENTO VENDITE

TEL: 01347 878 888
EMAIL: ciao@monstershop.eu

Per domande riguardo dispositivo, garanzia, reso o per riferire di guasti, utilizzare i dettagli sotto riportati.

DIPARTIMENTO SUPPORTO

TEL: 01347 878 887
EMAIL: help@monstershop.co.uk

Monster House, Alan Farnaby Way,
Sheriff Hutton Industrial Estate,
Sheriff Hutton, York, YO60 6PG
www.monstershop.co.uk



 Try **Monster**. Buy **Monster**. Be **Monster**. 

