



RATTAN CORNER DINING SET

26014 / 26015 / 26016

INSTRUCTION MANUAL

www.monstershop.co.uk





SPECIFICATION

PRODUCT DESCRIPTION

Thank you for purchasing this Rattan Corner Dining Set, the perfect garden furniture set. This fashionable set provides an ample seating area, ideal for large gatherings and parties. It is also low maintenance and easily cleaned with a damp cloth.

With a free rain cover, the Rattan Corner Dining Set is protected from all inclement weather and climates, the set also contains UV stabilisers to protect it from the sun.

Please refer to and read the Safe Working Practice to ensure prevention of injury or damage to the device before starting.

PRODUCT SPECIFICS

TABLE DIMENSIONS:	700 x 1200 x 660mm
L SHAPED SOFA DIMENSIONS:	1800 x 2400 x 700mm
STOOL DIMENSIONS:	400 x 400 x 330mm
SEAT CUSHION THICKNESS:	50mm
BACK CUSHION THICKNESS:	50 - 80mm

SAFETY ADVICE

SAFE WORKING PRACTICE

Please read through the Safe Working Practice to ensure prevention of injury or damage to the device.

Do not use this product for anything other than its intended purposes.

Ensure you have read and fully understood the instruction manual and safety advice before using this product.

We recommend that at least two people work together for the assembly.

Do not apply bodyweight to this product before it is installed.

Keep small parts away from children.

Ensure this product is fitted correctly.











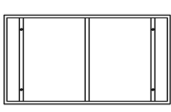
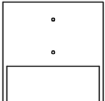

















Use this product on a flat surface.

Do not expose this product to fire.

Do not allow this product to get excessively hot.

SPECIFICATION

ITEM CONTENTS

			
A	1 PC	B	2 PCS
			
E	3 PCS	F	6 PCS
			
I	1 PC	J	1 PC
			
M	2 PCS	N	1 PC
			
Q	2 PCS	R	1 PCS
			
U	1 PC	V	12 PCS
			
Y	2 PCS	Z	20 PCS
		Y2	2 PCS
W	4 PCS	Y3	1 PC
X	106 PCS		

USER GUIDE

ASSEMBLY INSTRUCTIONS

1

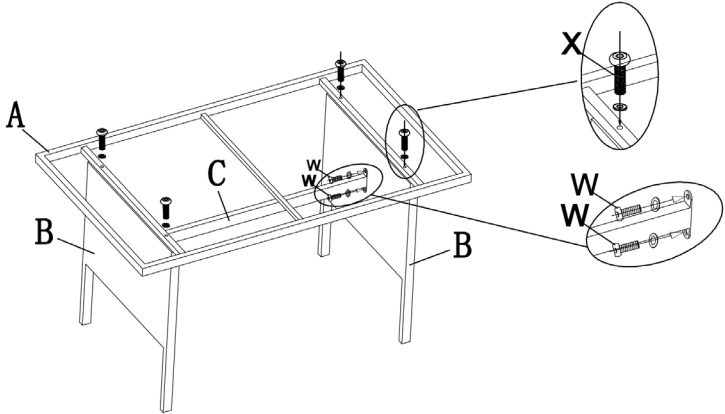

2

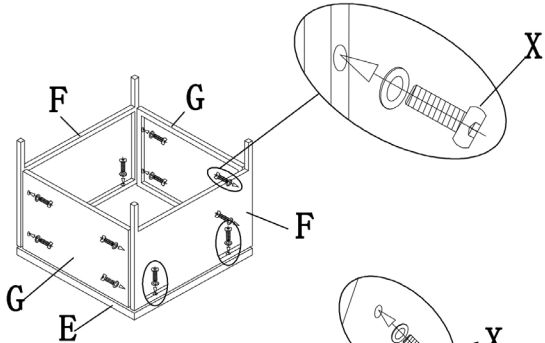

3

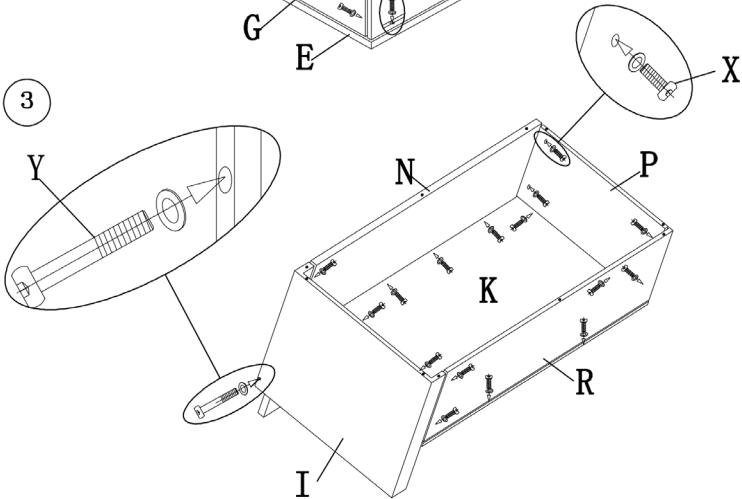

USER GUIDE

ASSEMBLY INSTRUCTIONS

4

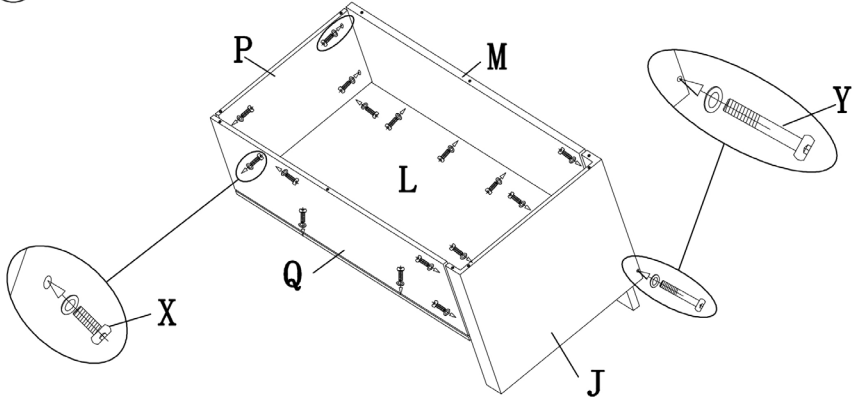

5

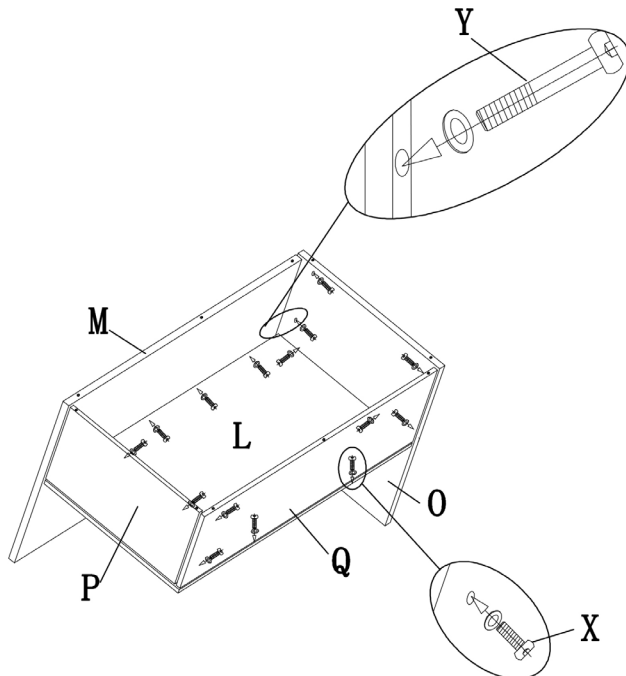

USER GUIDE

ASSEMBLY INSTRUCTIONS

6

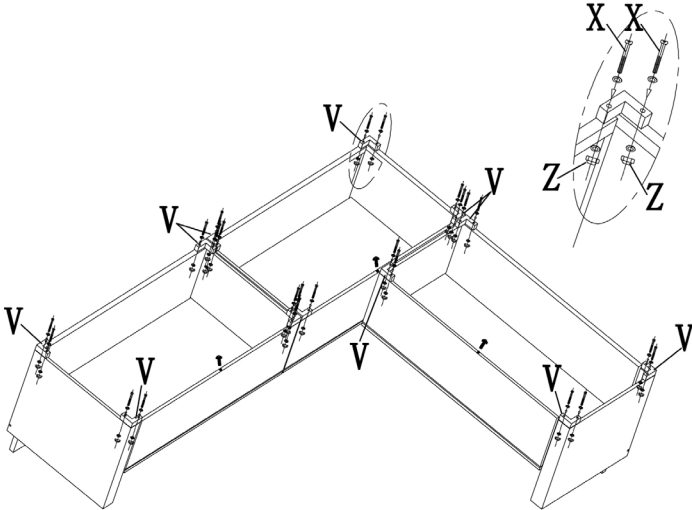

7

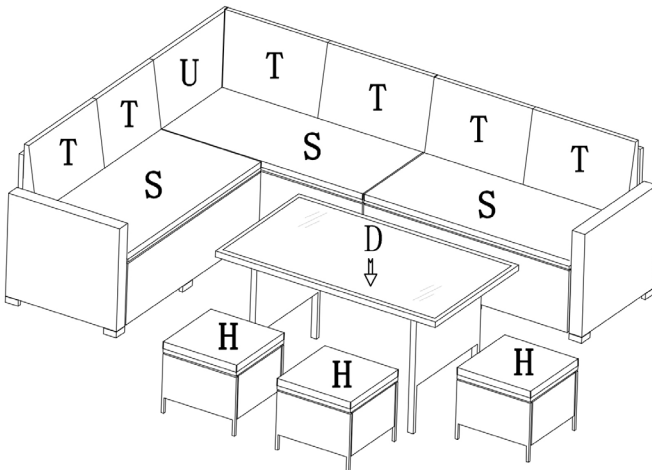

USER GUIDE

MAINTANENCE

- Remove cushions and place the rain cover over the furniture when it is not in use to ensure the furniture and table does not get wet.
- Check screws and bolts regularly to ensure the table top, stool and sofa components do not move.

TROUBLESHOOTING

RESOLUTION GUIDE

WHAT DO I DO IF THERE ARE MISSING PARTS FROM MY ORDER?

If there appears to be any part missing from your order, contact our friendly and helpful Customer Support Team within 7 days of receipt.

WHAT DO I DO IF THE FURNITURE STARTS TO WOBBLE/MOVE?

The screws and bolts need to be checked regularly to ensure they are tight and secure. Retighten any screws or bolts that are moving or loose.

**FOR ALL OTHER ISSUES, PLEASE CONTACT OUR
CUSTOMER SUPPORT TEAM.**

CONSEILS DE SÉCURITÉ

PRATIQUES DE TRAVAIL SÉCURITAIRE

Veillez lire attentivement les pratiques de travail sécuritaires pour éviter tout risque de blessure ou de détérioration de l'article.

Ne pas utiliser ce produit à des fins autres que celles prévues.

Assurez-vous d'avoir lu et compris le manuel d'instructions et les consignes de sécurité avant d'utiliser ce produit.

Nous recommandons au moins 2 personnes pour l'assemblage de ce produit.

Ne pas appliquer du poids corporel avant que le produit soit correctement installé.

Garder les petites parties hors de la portée des enfants.

Assurez que ce produit est muni correctement.

Utilisez ce produit sur une surface à plat.

Ne pas exposer ce produit près de flamme.

Ne laissez pas ce produit surchauffer.

SPÉCIFICATIONS

SPÉCIFICITÉS DU PRODUIT

DIMENSION TABLE:	700 x 1200 x 660mm
DIMENSION CANAPÉ EN FORME L:	1800 x 2400 x 700mm
DIMENSION TABOURET:	400 x 400 x 330mm
ÉPAISSEUR DU COUSSIN SIÈGE:	50mm
ÉPAISSEUR DU COUSSIN DOS:	50 - 80mm

MODE D'EMPLOI

ENTRETIEN

- Enlevez les coussins et placez la housse par dessus du mobilier pour éviter que le mobilier et la table deviennent mouillés.
- Vérifiez les vis et boulons de façons régulières pour assurer que le dessus de la table, tabouret et canapé ne se déplacent pas.

DÉPANNAGE

GUIDE DE DÉPANNAGE

QUE FAIRE S'IL MANQUE DES ÉLÉMENTS À MA COMMANDE?

Si vous constatez qu'une ou plusieurs pièces manquent à votre commande, contactez notre équipe du service clients dans les 7 jours suivant sa réception.

QUE FAIRE SI LE MOBILIER COMMENCE A SE DÉPLACER?

Les vis et les boulons doivent être vérifier pour assurer qu'ils sont sécurisés et serrés. Resserrez tout vis et boulons qui semblent desserrer ou se déplacent.

POUR TOUT AUTRE DEMANDE, VEUILLEZ CONTACTER NOTRE ÉQUIPE DU SERVICE CLIENT



SICHERHEITSHINWEISE



SICHERE ARBEITSVERFAHREN

Bitte lesen Sie sich die Sicherheitshinweise durch um sicherzustellen, Verletzungen oder Schäden am Gerät zu vermeiden.

Verwenden Sie dieses Produkt nur für die vorgesehenen Zwecke.

Stellen Sie sicher, dass Sie die Bedienungsanleitung und Sicherheitshinweise gelesen und verstanden haben bevor Sie dieses Produkt benutzen.

Wir empfehlen mindestens zwei Personen für die Montage.

Üben Sie kein Körpergewicht auf dieses Produkt aus, bevor es installiert ist.

Halten Sie Kleinteile von Kindern fern.

Stellen Sie sicher, dass dieses Produkt korrekt montiert ist.

Benutzen Sie dieses Produkt auf einer flachen Oberfläche.

Setzen Sie das Produkt keinem Feuer aus..

Lassen Sie dieses Produkt nicht allzu heiß werden.

SPEZIFIKATIONEN

PRODUKTMERKMALE

TISCHMAßE:	700 x 1200 x 660mm
SOFA L-FORM MAßE:	1800 x 2400 x 700mm
HOCKERMAßE:	400 x 400 x 330mm
DICKE DER SITZKISSEN:	50mm
DICKE DER RÜCKENKISSEN:	50 - 80mm

BENUTZERHANDBUCH

INSTANDHALTUNG

- Nehmen Sie die Kissen vom Sofa und decken Sie die Möbel mit dem Regenschutz ab, wenn diese nicht benutzt werden, um sicherzustellen, dass die Möbel und der Tisch nicht nass werden.
- Überprüfen Sie regelmäßig die Schrauben und Bolzen, um sicherzustellen, dass die Tischoberfläche, der Hocker und die Sofakomponenten nicht verrutschen.

FEHLERBEHEBUNG

PROBLEMLÖSUNG

WAS MACHE ICH, WENN IN MEINER BESTELLUNG TEILE FEHLEN?

Wenn in Ihrer Bestellung ein Teil fehlt, wenden Sie sich innerhalb von 7 Tagen nach Erhalt des Produktes an unser freundliches und hilfsbereites Kundendienstteam.

WAS TUN, WENN DIE MÖBEL BEGINNEN, SICH ZU BEWEGEN?

Die Schrauben und Bolzen müssen regelmäßig überprüft werden, um sicherzugehen, dass sie fest und sicher sind. Jegliche lockeren Schrauben oder Bolzen müssen nachgezogen werden.

**FÜR ALLE ANDEREN FRAGEN WENDEN SIE SICH BITTE AN
UNSER KUNDENDIENSTTEAM.**



CONSEJOS DE SEGURIDAD



PRÁCTICAS DE TRABAJO SEGURAS

Lea las Prácticas de trabajo seguras para garantizar la prevención de lesiones o daños al dispositivo.

No utilice este producto para ningún otro fin que no sea el previsto.

Asegúrese de haber leído y entendido completamente el manual de instrucciones y los consejos de seguridad antes de usar este producto.

Le recomendamos que al menos 2 personas trabajen juntas para el montaje.

No aplique peso corporal a este producto antes de instalarlo.

Mantenga las piezas pequeñas fuera del alcance de los niños.

Asegúrese de que este producto esté instalado correctamente.

Use este producto sobre una superficie plana.

No exponga este producto al fuego.

No permita que este producto se caliente demasiado.

ESPECIFICACIONES

ESPECIFICACIONES DEL PRODUCTO

DIMENSIONES DE MESA:	700 x 1200 x 660mm
DIMENSIONES DE L SOFÁ EN FORMA DE L:	1800 x 2400 x 700mm
DIMENSIONES DE TABURETE:	400 x 400 x 330mm
ESPESOR DEL COJÍN DEL ASIENTO:	50mm
ESPESOR DEL COJÍN DEL ESPALDA:	50 - 80mm

GUÍA DE USUARIO

MANTENIMIENTO

- Retire los cojines y coloque la cubierta de lluvia sobre los muebles cuando no esté en uso para asegurarse de que los muebles y la mesa no se mojen.
- Revise los tornillos y pernos regularmente para asegurarse de que los componentes de la mesa, el taburete y el sofá no se muevan.

RESOLUCIÓN DE PROBLEMAS

GUÍA DE RESOLUCIÓN

¿QUÉ DEBO HACER SI FALTAN PIEZAS EN MI PEDIDO?

Si faltan piezas en su pedido, póngase en contacto con nuestro atento y amable Equipo de Atención al Cliente durante 7 días siguientes a la compra.

¿QUÉ HAGO SI EL MUEBLE COMIENZA A TAMBALEARSE/ MOVERSE?

Los tornillos y pernos deben revisarse regularmente para asegurarse de que estén apretados y seguros. Vuelva a apretar los tornillos o pernos que se mueven o están flojos.

**PARA CUALQUIER OTRA CUESTIÓN, NO DUDE EN CONTACTAR
CON NUESTRO EQUIPO DE ATENCIÓN AL CLIENTE.**

INFORMAZIONI DI SICUREZZA

PROCEDURE OPERATIVE DI SICUREZZA

Prego leggere la procedura di lavoro sicuro per prevenire lesioni o danni al dispositivo.

Non usare questo prodotto per scopi diversi da quelli previsti.

Assicurarsi di aver letto e compreso il manuale di istruzioni e l'avviso di sicurezza prima di adoperare il prodotto.

Raccomandiamo almeno due persone per il montaggio.

Non sottoporre peso al prodotto prima di averlo installato.

Tenere i piccolo componenti lontano dalla portata dei bambini.

Assicurarsi che il prodotto sia installato correttamente.

Usare questo prodotto su una superficie piana.

Non esporre il prodotto al fuoco.

Non lasciare il prodotto in un ambiente eccessivamente caldo.

SPECIFICHE

SPECIFICHE DEL PRODOTTO

DIMENSIONE TAVOLO:	700 x 1200 x 660mm
DIMENSIONI DIVANO A L	1800 x 2400 x 700mm
DIMENSIONI SGABELLO:	400 x 400 x 330mm
SPESSORE SEDUTA SCHIENALE:	50mm
SPESSORE CUSCINO SCHIENALE:	50-80mm

ISTRUZIONI PER L'USO

MANUTENZIONE

- Rimuovere i cuscini e applicare la copertura per la pioggia quando non in uso per assicurarsi che i mobili non si bagnino.
- Controllare viti e bulloni regolarmente per assicurarsi che i componenti non siano instabili.

RISOLUZIONE DEI PROBLEMI

GUIDA ALLA RISOLUZIONE

COSA DEVO FARE SE MANCANO DEI PEZZI NEL MIO ORDINE?

Se nel tuo ordine sembra che manchino dei pezzi, contatta il nostro servizio clienti entro 7 giorni dal ricevimento.

COSA FARE SE I MOBILI DOVESSERO INIZIARE A TRABALLARE?

Viti e bulloni necessitano controlli regolari per assicurarsi che siano fissati correttamente. Stringere le viti o i bulloni allentati.

**PER TUTTE LE ALTRE QUESTIONI, CONTATTARE IL NOSTRO
TEAM DI SERVIZIO CLIENTI.**



VEILIGHEIDSADVIES



VEILIG GEBRUIK

Gelieve het veiligheidsblad goed door te lezen om letsel of schade aan het product te voorkomen.

Gebruik dit product niet voor iets anders dan waar het product voor bedoeld is.

Zorg ervoor dat u, alvorens het product te gebruiken, de gebruikshandleiding en het veiligheidsblad volledig gelezen en begrepen heeft.

Het is aanbevolen om het met ten minste 2 personen samen in elkaar te zetten

Niet op het product leunen voordat het volledig is opgezet.

Houd kleine onderdelen uit de buurt van kinderen.

Zorg ervoor dat het product correct in elkaar gezet is.

Gebruik dit product alleen op een vlak oppervlak.

Stel het product niet bloot aan hitte of open vuur.

Laat dit product niet te heet worden.

OMSCHRIJVING

PRODUCT SPECIFICATIES

TAFELAFMETINGEN:	700 x 1200 x 660mm
L GEVORMDE BANKAFMETINGEN:	1800 x 2400 x 700mm
STOOL AFMETINGEN:	400 x 400 x 330mm
ZITKUSSEN DIKTE	50mm
RUGKUSSEN DIKTE	50 - 80mm

GEBRUIKERSHANDLEIDING

ONDERHOUD

- Verwijder de kussens en plaats de regenhoes over de tuinset wanneer niet in gebruik zodat de tafel en de stoelen niet nat worden.
- Controleer regelmatig de schroeven en bouten om te controleren of het tafelblad, de kruk en de bankonderdelen niet bewegen.

PROBLEEMOPLOSSING

RESOLUTIEGIDS

WAT DOE IK ALS ER ONDERDELEN VAN MIJN BESTELLING ONTBREKEN?

Als er een onderdeel ontbreekt in uw bestelling, neem dan binnen 7 dagen na ontvangst contact op met onze vriendelijke en behulpzame klantenservice.

WAT MOET IK DOEN ALS DE MEUBILAIR BEGINT TE WAGGELEN / BEWEGEN?

De schroeven en bouten moeten regelmatig worden gecontroleerd om ervoor te zorgen dat ze goed vastzitten. Draai alle schroeven of bouten vast die bewegen of loszitten.

**NEEM VOOR ALLE ANDERE PROBLEMEN CONTACT OP MET
ONZE KLANTENSERVICE**

Monster Group (UK) is one of the UK's fastest growing online retailers. We supply a diverse range of products which offer exceptional value for money. We strive to provide the best possible customer experience with free UK delivery across all our products and a Monster Guarantee for 100% satisfaction.

For information regarding this device or other products from our Monster divisions please contact Sales.

SALES

TEL: 01347 878 888

EMAIL: hello@monstershop.co.uk

For queries about this device, warranty, returns or reporting faults please contact Support.

SUPPORT

TEL: 01347 878 887

EMAIL: help@monstershop.co.uk

Pour plus d'informations concernant cet appareil ou d'autres produits de nos divisions de Monster veuillez utiliser les détails suivants ci-dessous.

DÉPARTEMENT COMMERCIAL

TEL: 01347 878 888

EMAIL: bonjour@monstershop.eu

Pour les interrogations concernant cet appareil, la garantie, les retours ou les défauts de déclaration veuillez utiliser les détails suivants ci-dessous.

DÉPARTEMENT DE SOUTIEN

TEL: 01347 878 887

EMAIL: help@monstershop.co.uk

Para información sobre este dispositivo u otros productos de nuestras divisiones de Monster por favor use los siguientes detalles.

DEPARTAMENTO DE VENTAS

TEL: 01347 878 888

EMAIL: hola@monstershop.eu

Para consultas sobre este dispositivo, la garantía, devoluciones o denuncias de fallos por favor use los siguientes detalles.

DEPARTAMENTO DE SOPORTE

TEL: 01347 878 887

EMAIL: help@monstershop.co.uk

Für Informationen bezüglich dieses Geräts oder anderer Produkte aus unserer Monster-Abteilung, benutzen sie die folgenden unten aufgeführten Angaben.

VERKAUFABTEILUNG

TEL: 01347 878 888

EMAIL: hallo@monstershop.eu

Für Fragen über dieses Gerät, die Garantie, Rückgaben oder bei Störungen, benutzen sie die folgenden unten aufgeführten Angaben.

SUPPORT-ABTEILUNG

TEL: 01347 878 887

EMAIL: help@monstershop.co.uk

Per informazioni riguardanti questo dispositivo o altri prodotti dalle categorie Monster utilizzare i dettagli sotto riportati.

DIPARTIMENTO VENDITE

TEL: 01347 878 888

EMAIL: ciao@monstershop.eu

Per domande riguardo dispositivo, garanzia, reso o per riferire di guasti, utilizzare i dettagli sotto riportati.

DIPARTIMENTO SUPPORTO

TEL: 01347 878 887

EMAIL: help@monstershop.co.uk

Monster House, Alan Farnaby Way,
Sheriff Hutton Industrial Estate,
Sheriff Hutton, York, YO60 6PG
www.monstershop.co.uk



 Try **Monster**. Buy **Monster**. Be **Monster**. 