



WORKBENCH WITH DRAWER

26115/26462/26463

INSTRUCTION MANUAL

www.monstershop.co.uk



SPECIFICATION

PRODUCT DESCRIPTION

Our Workbench with Drawer is the perfect solution to your storage needs. With it's Large bottom self, sturdy work area, handy drawer and upper shelf it's ample storage will keep your garage spick and span!

PRODUCT SPECIFICS

Width:	120cm
Height:	150cm
Depth:	60cm
Top Shelf Capacity:	30KG
Bottom Shelf Capacity:	100KG
Work Area Capacity:	200KG
Drawer Capacity:	40KG

PRODUCT FEATURES

- A. Top Shelf
- B. Bottom Shelf
- C. Drawer
- D. Work Area
- E. Peg Board



SPECIFICATION

PARTS LIST

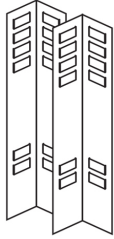

A Front Legs - x2



B Back Left Leg - x1



C Back Right Leg - x1

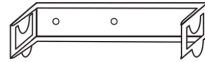

D Left Drawer Support - x1

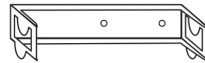

E Right Drawer Support - x1

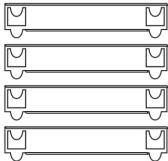

F Short Worktop Supports - x4

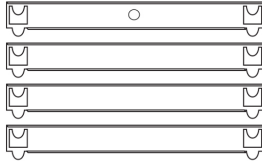

G Long Worktop Supports - x4



H Left Vertical Support - x1



I Right Vertical Support - x1



J1 Back Support



K Left Top Shelf Support - x1

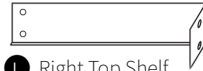

L Right Top Shelf Support - x1



J2 Front Support



M Drawer Front - x1



N Drawer Back - x1



O Drawer Sides (Short) - x2



P Drawer Base - x1

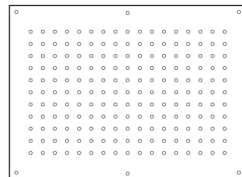

Q Peg Board - x1

Monster Group UK Limited's liability will be limited to the commercial value of the product only.

SPECIFICATION

PARTS LIST



R Bottom Shelf - x1



S Worktop - x1

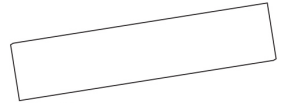

T Top Shelf - x1

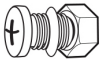

V Short Fixings - x30

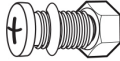

W Long Fixings - x6



X Nuts/Bolts (Small) - x16

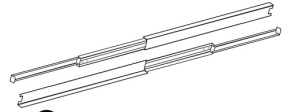

U Drawer Runners - x2



Y Pegboard Supports - x1

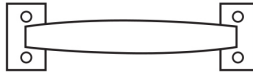

S1 Drawer Handles - x2



S2 Pegs - x40



S3 Cap Feet - x4

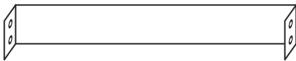

S4 Drawer Support - x1



S5 Support Bars - x2



Z Rubber Mallet - x1

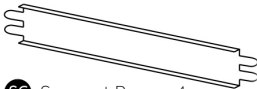

S6 Support Bars - x4

SAFETY ADVICE

SAFE WORKING PRACTICE

- Follow the instructions provided whilst constructing this product.
- Ensure you have fully understood the instructions and safety advice before proceeding with construction.
- Do not use this product for anything other than its intended use.
- Always keep the weight evenly distributed to avoid damage to the workbench or MDF and to prevent the workbench from falling over.
- Do not alter or modify this product in any way.
- We recommend hiring a qualified professional to construct and/or install the workbench.
- Keep your construction area clear of clutter.
- Use this product on a flat surface.
- Ensure children, pets/animals and inexperienced users are not in the vicinity when constructing this workbench.
- Do not exceed the load bearing capacity shown in the product specifics on page 2.
- Regularly inspect the product for damage and sign of wear. Tighten any components that appear to be loose.
- Ensure the moulded feet are attached correctly to prevent any potential injury.
- Treat the MDF boards with varnish or mould prevention products if using in a humid environment.
- We recommend two people to assemble the product.

USER GUIDE

ASSEMBLY INSTRUCTIONS

In order to allow room for the tabs to fit securely, it is recommended that you gently prise the tabs open using a suitable flat head screwdriver (not supplied). Once the tabs have been inserted, gently tap shut using a suitable rubber mallet to secure.

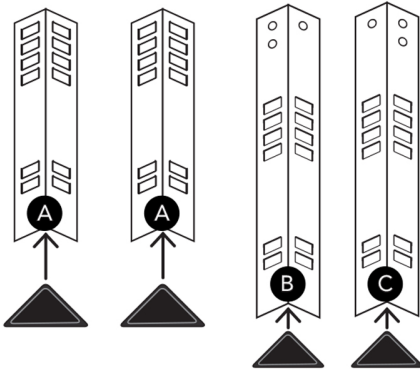

STEP 1:

Clip the 4 Cap Feet (S3) onto the ends of the Legs (A, B, C) as illustrated.

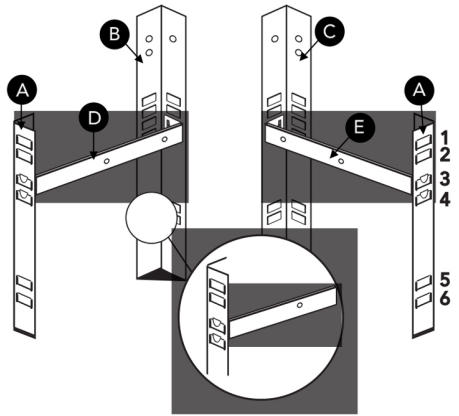

STEP 2:

Fit the Drawer Supports (D, E) between the Front and Back Legs (A, B, C) and secure as illustrated.

The Drawer Supports should be fitted between the 3rd and 4th slots and face outwards.

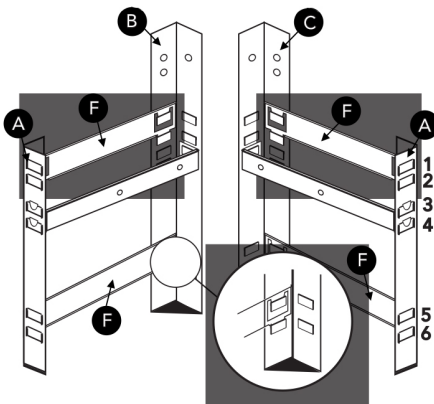

STEP 3:

Fit the 4 Worktop Supports (F) to the Front and Back Legs (A, B, C) as illustrated.

The Short Worktop Supports should be positioned between the 1st/2nd and 5th/6th slots.

USER GUIDE

ASSEMBLY INSTRUCTIONS

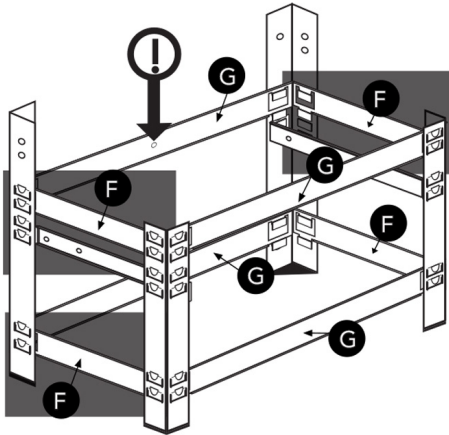

STEP 4:

Fit the 4 Long Worktop Supports (G) to the Front and Back Legs (A, B, C) at the 1st/2nd and 5th/6th slots.

The Long Worktop Support with the central hole should be positioned between the 1st/2nd slots on the Back Legs (B, C).

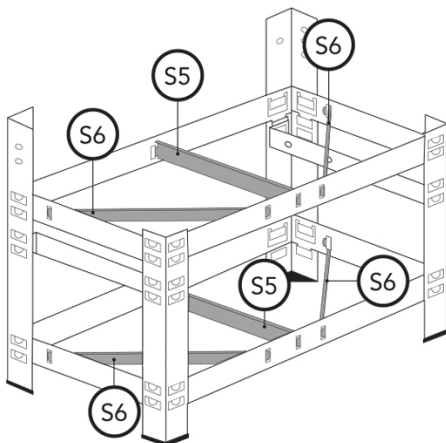

STEP 4.1:

Fit the supports (S5 & S6) to the frame.

STEP 5:

Bend the tabs on each end of the Support Bars (S5) to a 90° angle. Locate the slots at the top and bottom and slot into place between the Front & Rear Side Beams (G).

Bend the tabs back on themselves (as shown below) to attach.

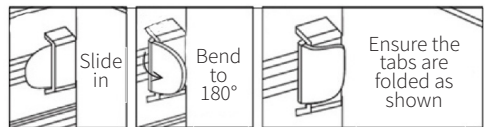

Fit the Left and Right Upper Vertical Supports (H, I) into the sides of the Back Legs (B, C).

Secure using 4 Short Fixings (V).

Tighten with a suitable spanner to secure. Secure the Support Bars (S5) into place using (W).

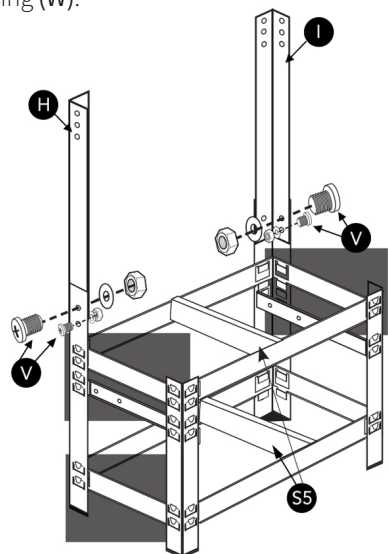

USER GUIDE

ASSEMBLY INSTRUCTIONS

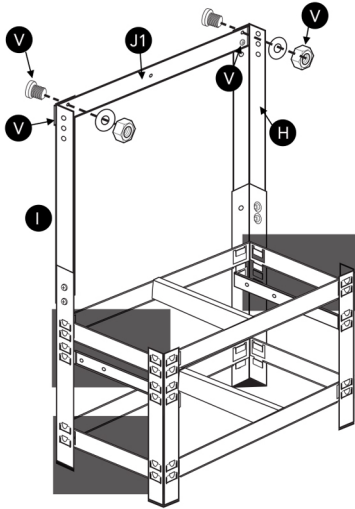

STEP 6:
Fix the Back Support (J1) to the top 2 holes of the Vertical Supports (H, I). Secure using 4 Short Fixings (V). Tighten to secure.

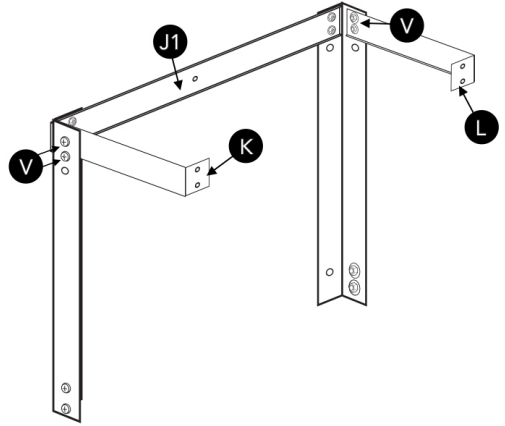

STEP 7:
Fix the longest edge of the Short Top Shelf Supports (K, L) to the top 2 holes of the Vertical Supports (H, I) using 4 Short Fixings (V) as illustrated. Tighten to secure.

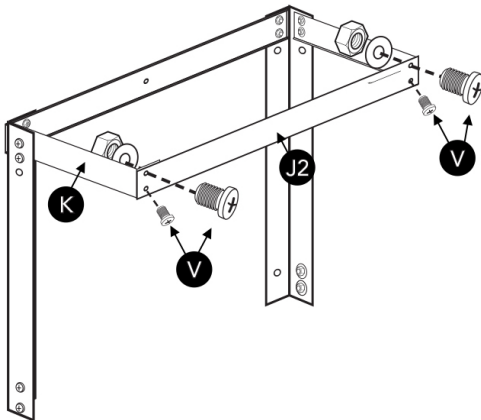

STEP 8:
Fix the Front Support (J2) to the front of the Short Top Shelf Supports (K, L) using 4 Short Fixings (V) as illustrated. Tighten to secure.

USER GUIDE

ASSEMBLY INSTRUCTIONS

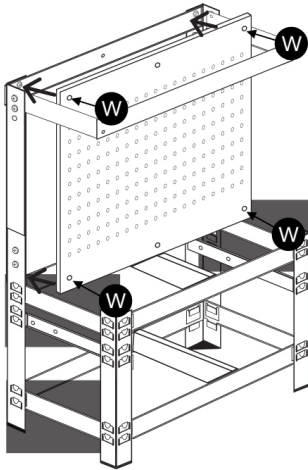

STEP 9:
Fix Peg Board (Q) with 4 Long Fixings (W).
Tighten to secure.

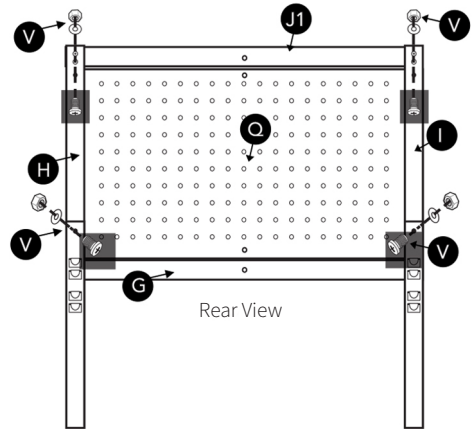

STEP 10:
From the rear, insert 4 Short Fixings (V) into
the vacant holes in the Vertical Supports
(H, I). Tighten to secure.

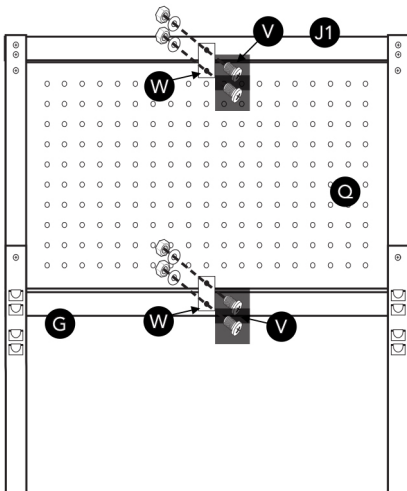

STEP 11:
Using 2 Short Fixings (V), attach the
Pegboard Supports (Y) to the rear of the
assembly through the vacant holes on the
Long Supports (G, J1).

Insert 2 Long Fixings (W) into the vacant
holes on the Pegboard Supports (Y) and
into the Pegboard (Q). Tighten all to secure.

USER GUIDE

ASSEMBLY INSTRUCTIONS

STEP 12:

Fix the 2 Drawer Handles (**S1**) to the Drawer Front (**M**) by inserting 8 Small Nuts/Bolts (**X**) from the outside in towards the ledge. Tighten to secure.

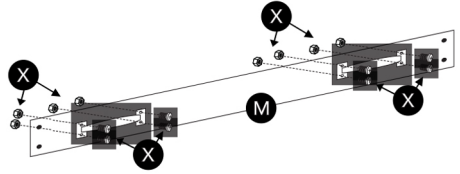

STEP 13:

Fix the Short Drawer Sides (**O**) to the Drawer Front (**M**) using 4 Short Fixings (**V**). Tighten to secure.

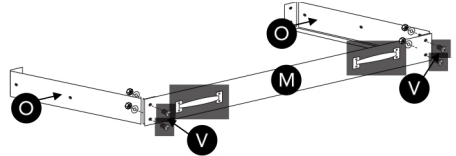

STEP 14:

Lower the Drawer Base (**P**) into the Drawer Assembly to rest on the inner ledges. Fix the Long Drawer Back (**N**) to the assembly using 4 Short Fixings (**V**).

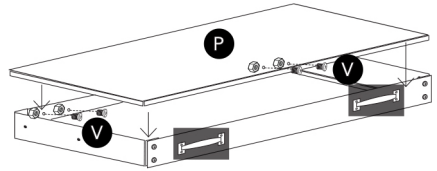

STEP 15:

Fix the 2 Drawer Runners (**U**) to the Short Drawer Sides (**O**) using 4 Small Nuts/Bolts (**X**) through the available holes as illustrated. Tighten to secure.

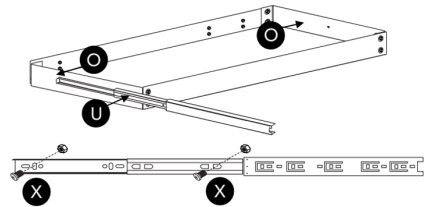

STEP 16:

Holding the drawer within the Workbench assembly, extend and align the Drawer Runners (**U**) with the fixing holes in the Drawer Supports (**D, E**). Insert 4 Small Fixings (**X**) through the Runners and into the Supports. Tighten to secure.

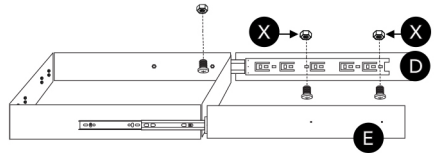

Insert the Drawer Support (**S4**) into the centre of the drawer and secure in place using (**W**).

USER GUIDE

ASSEMBLY INSTRUCTIONS

STEP 17:

Fit the Top Shelf (T), Worktop (S) and Bottom Shelf (R) by gently lowering them into the appropriate levels on the Workbench as illustrated.

ADDITIONAL: Insert Pegs (S2) into the Pegboard (Q) to hang tools for convenience.

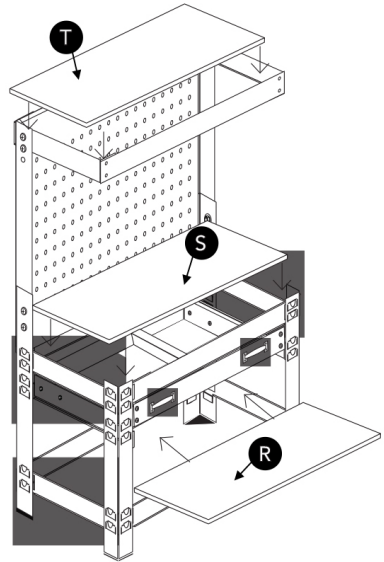

TROUBLESHOOTING

RESOLUTION GUIDE

WHAT DO I DO IF THERE ARE MISSING PARTS FROM MY ORDER?

If there appears to be any part missing from your order, contact our friendly and helpful Customer Support Team within 7 days of receipt.

**FOR ALL OTHER ISSUES, PLEASE CONTACT OUR
CUSTOMER SUPPORT TEAM.**

SPÉCIFICATIONS

DESCRIPTION DU PRODUIT

Notre établi avec tiroir est la solution parfaite pour vos besoins de rangement. Avec son grand plateau inférieur, son espace de travail robuste, son tiroir pratique et son plateau supérieur, il offre un grand espace de rangement qui vous permettra de garder votre garage bien rangé !

SPÉCIFICATIONS DU PRODUIT

Largeur :	120 cm
Hauteur :	150 cm
Profondeur :	60 cm
Capacité du plateau supérieur :	30 KG
Capacité du plateau inférieur :	100 KG
Capacité du plan de travail :	200 KG
Capacité des tiroirs :	40 KG

CARACTÉRISTIQUES DU PRODUIT

- A. Plateau supérieur
- B. Plateau inférieur
- C. Tiroir
- D. Plan de travail
- E. Paroi Perforée



SPÉCIFICATIONS

Liste des pièces

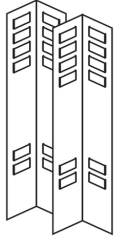

A Pieds avants - x2



B Pied arrière gauche - x1



C Pied arrière droite - x1

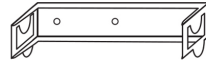

D Support tiroir gauche - x1

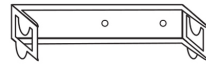

E Support tiroir droite - x1

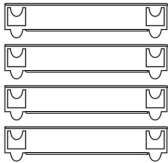

F Supports courts plan de travail - x4

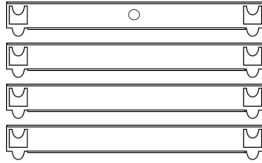

G Supports longs plan de travail - x4



H Support vertical gauche - x1



I Support vertical droite - x1



J1 Support arrière



K Support plateau supérieur gauche - x1



L Support plateau supérieur droite - x1



J2 Support avant



M Avant tiroir - x1

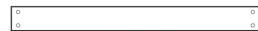

N Arrière tiroir - x1

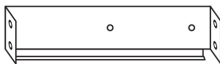

O Côtés tiroirs (court) - x2



P Base tiroir - x1

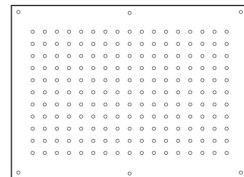

Q Paroi Perforée - x1

La responsabilité de Monster Group UK Limited sera limitée à la valeur commerciale du produit.

SPÉCIFICATION

Liste des pièces



R Plateau inférieur - x1



S Plan de travail - x1

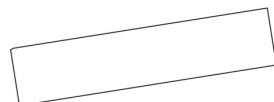

T Plateau supérieur - x1



V Visseries courtes - x30

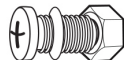

W Visseries longues - x6



X Écrous/boulons (petits) - x16

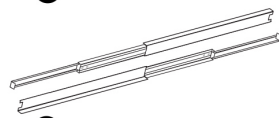

U Coulisses de tiroir - x2



Y Supports de paroi perforée - x1

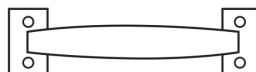

S1 Poignées de tiroir - x2



S2 Chevilles - x40



S3 Tampons de pieds - x4

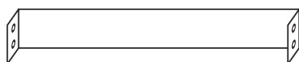

S4 Support tiroir - x1



S5 Barres de soutien - x2

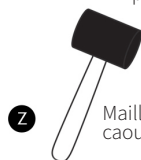

Z Maillet en caoutchouc - x1



S6 Barres de soutien - x4

CONSEILS DE SÉCURITÉ

PRATIQUES DE TRAVAIL SÉCURITAIRES

- Suivez les instructions fournies lors de l'assemblage de ce produit.
- Assurez-vous d'avoir bien compris les instructions et les conseils de sécurité avant de poursuivre avec l'assemblage.
- N'utilisez pas ce produit pour autre chose que l'usage auquel il est destiné.
- Veillez à ce que le poids soit toujours réparti uniformément pour éviter d'endommager l'établi ou le MDF et pour éviter que l'établi ne tombe.
- Ne pas altérer ou modifier ce produit de quelque manière que ce soit.
- Nous recommandons d'engager un professionnel qualifié pour assembler et/ou installer l'établi.
- Veillez à ce que votre zone d'assemblage ne soit pas encombrée.
- Utilisez ce produit sur une surface plane.
- Veillez à ce que les enfants, les animaux domestiques et les utilisateurs inexpérimentés ne se trouvent pas à proximité durant l'assemblage de cet établi.
- Ne pas dépasser la capacité de charge indiquée dans les caractéristiques du produit à la page 2.
- Inspectez régulièrement le produit pour détecter les dommages et les signes d'usure. Serrez tous les composants qui semblent lâches.
- Assurez-vous que les pieds moulés sont correctement fixés pour éviter toute blessure potentielle.
- Traitez les panneaux MDF avec du vernis ou des produits anti-moisissure s'ils sont utilisés dans un environnement humide.
- Nous recommandons d'assembler le produit à deux personnes.

MODE D'EMPLOI

INSTRUCTIONS DE MONTAGE

Afin de laisser de la place pour les languettes, il est recommandé de les ouvrir doucement à l'aide d'un tournevis à tête plate approprié (non fourni). Une fois les languettes insérées, fermez-les doucement en tapotant avec un maillet en caoutchouc approprié pour les fixer.

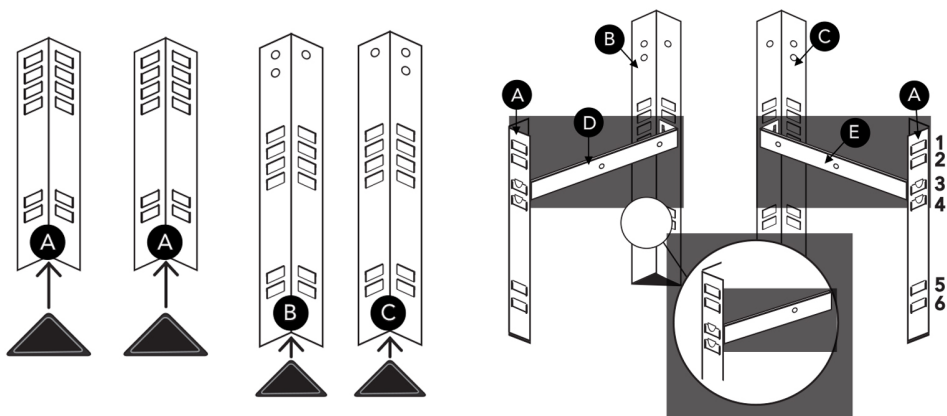

ÉTAPE 1 :

Clipsez les 4 tampons de pieds (S3) sur les extrémités des pieds (A, B, C) comme illustré.

ÉTAPE 2 :

Placez les supports de tiroir (D, E) entre les pieds avant et arrière (A, B, C) et fixez-les comme illustré.

Les supports de tiroir doivent être placés entre les 3e et 4e fentes et être orientés vers l'extérieur.

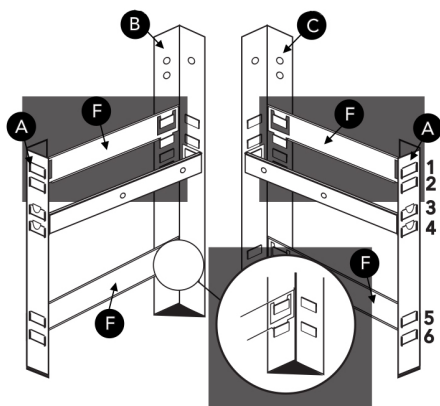

ÉTAPE 3 :

Montez les 4 supports de plan de travail (F) sur les pattes avant et arrière (A, B, C) comme illustré.

Les supports de plan de travail courts doivent être placés entre les emplacements 1/2 et 5/6.

MODE D'EMPLOI

INSTRUCTIONS DE MONTAGE

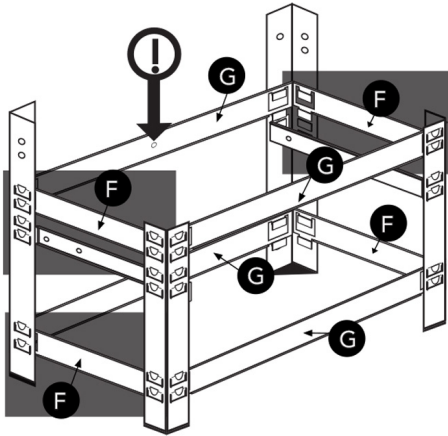

ÉTAPE 4 :

Fixez les 4 longs supports de plan de travail (G) aux pieds avant et arrière (A, B, C) aux emplacements 1/2 et 5/6.

Le support de plan de travail long avec le trou central doit être placé entre les fentes 1 et 2 des pieds arrière (B, C).

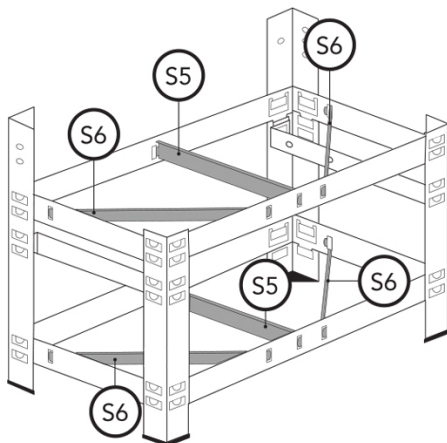

ÉTAPE 4.1:

Fixez les supports (S5 et S6) au cadre.

ÉTAPE 5 :

Pliez les languettes à chaque extrémité des barres de support (S5) à un angle de 90°. Repérez les fentes en haut et en bas et mettez-les en place entre les poutres latérales avant et arrière (G).

Repliez les languettes sur elles-mêmes (comme indiqué ci-dessous) pour les attacher.

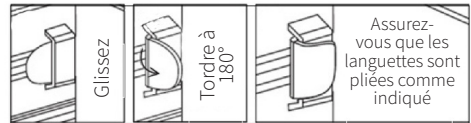

Placez les supports verticaux supérieurs gauche et droit (H, I) sur les côtés des pieds arrière (B, C).

Sécurisez à l'aide de 4 vis courtes (V).

Serrez avec une clé appropriée pour sécuriser. Fixez les barres de soutien (S5) en place à l'aide de (W).

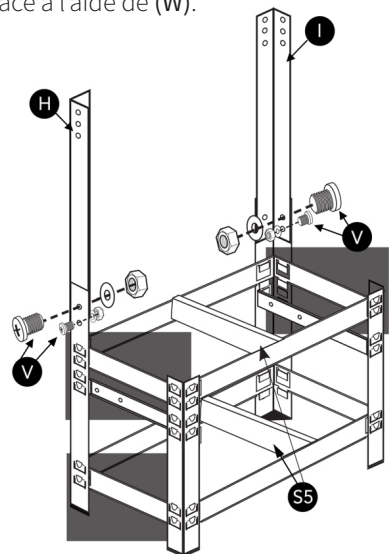

MODE D'EMPLOI

INSTRUCTIONS DE MONTAGE

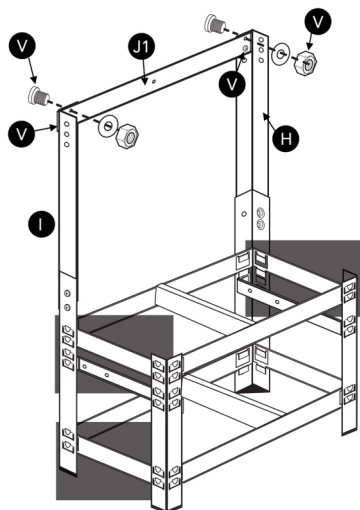

ÉTAPE 6 :

Fixez le support dorsal (J1) au sommet 2 trous des supports verticaux (H, I). Fixez à l'aide de 4 vis courtes (V). Serrez pour sécuriser.

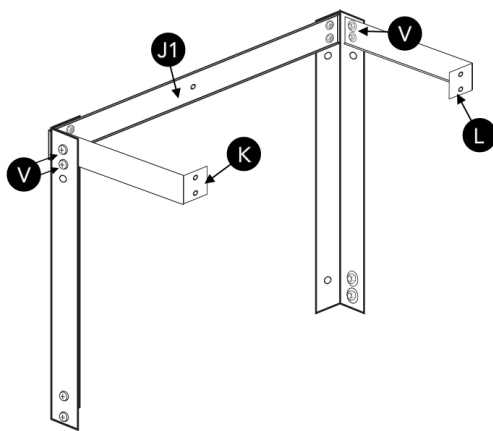

ÉTAPE 7 :

Fixez le bord le plus long des supports courts du plateau supérieur (K, L) aux deux trous supérieurs des supports verticaux (H, I) à l'aide de quatre vis courtes (V), comme illustré. Serrez pour sécuriser.

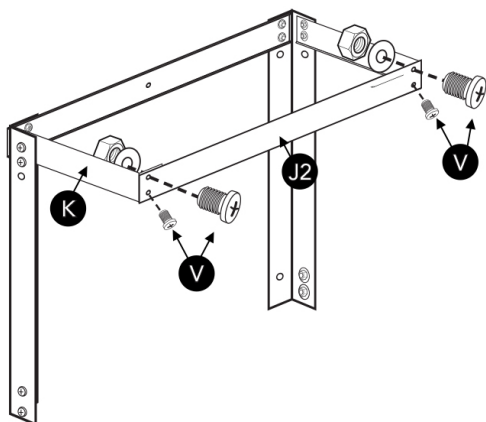

ÉTAPE 8 :

Fixez le support avant (J2) à l'avant des supports courts du plateau supérieur (K, L) à l'aide de 4 vis courtes (V) comme illustré. Serrez pour sécuriser.

MODE D'EMPLOI

INSTRUCTIONS DE MONTAGE

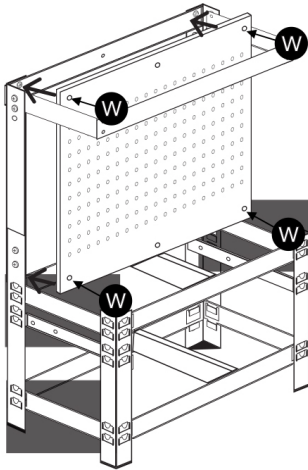

ÉTAPE 9 :
Fixez la paroi perforée (Q) avec 4 vis longues (W). Serrez pour sécuriser.

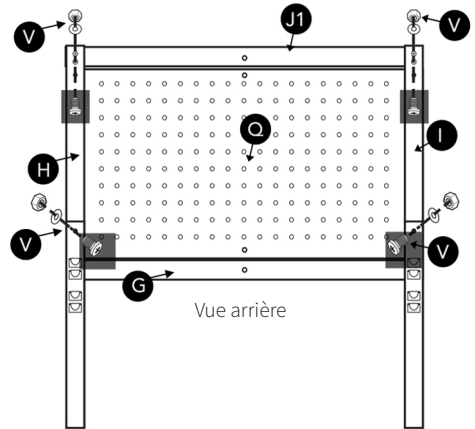

ÉTAPE 10 :
Par l'arrière, insérez 4 vis courtes (V) dans les trous libres des supports verticaux (H, I). Serrez pour sécuriser.

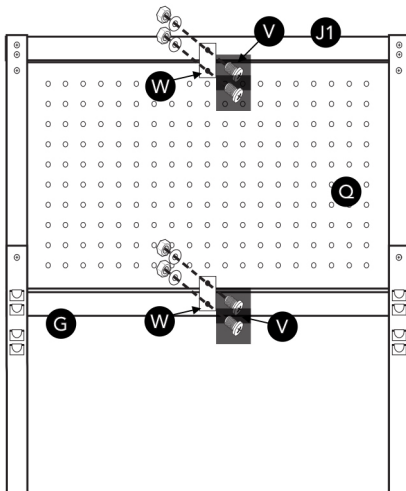

ÉTAPE 11 :
À l'aide de deux vis courtes (V), fixez la paroi perforée (Y) à l'arrière de l'ensemble par les trous libres des supports longs (G, J1).
Insérez 2 vis longues (W) dans les trous libres des supports du paroi perforée (Y) et dans la paroi perforée (Q). Serrez tout pour fixer.

MODE D'EMPLOI

INSTRUCTIONS DE MONTAGE

ÉTAPE 12 :

Fixez les 2 poignées de tiroir (**S1**) à la façade de tiroir (**M**) en insérant 8 petits écrous/boulons (**X**) de l'extérieur vers l'intérieur en direction du rebord. Serrez pour sécuriser.

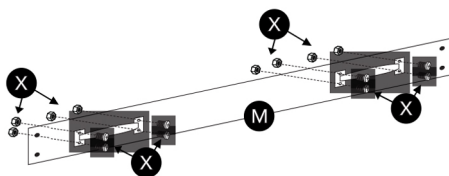

ÉTAPE 13 :

Fixez les côtés courts du tiroir (**O**) à la façade du tiroir (**M**) à l'aide de 4 vis courtes (**V**). Serrez pour sécuriser.

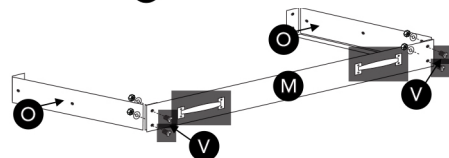

ÉTAPE 14 :

Abaissez le fond du tiroir (**P**) dans l'ensemble du tiroir pour qu'il repose sur les rebords intérieurs. Fixez le fond de tiroir long (**N**) à l'ensemble à l'aide de 4 vis courtes (**V**).

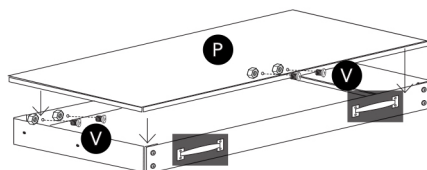

ÉTAPE 15 :

Fixez les 2 glissières de tiroir (**U**) sur les côtés courts du tiroir (**O**) à l'aide de 4 petits écrous/boulons (**X**) à travers les trous disponibles comme illustré. Serrez pour sécuriser.

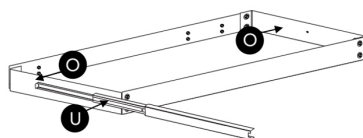

ÉTAPE 16 :

En tenant le tiroir dans l'ensemble Workbench, sortez et alignez les glissières de tiroir (**U**) avec les trous de fixation des supports de tiroir (**D, E**). Insérez 4 petites vis (**X**) à travers les glissières et dans les supports. Serrez tout pour fixer.

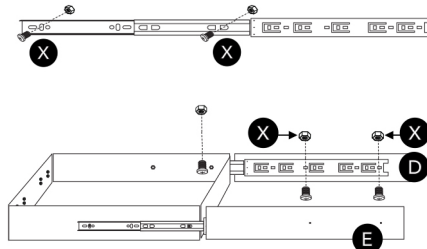

Insérez le support de tiroir (**S4**) au centre du tiroir et fixez-le en place à l'aide de (**W**).

MODE D'EMPLOI

INSTRUCTIONS DE MONTAGE

ÉTAPE 17 :

Montez le plateau supérieur (T), le plan de travail (S) et le plateau inférieur (R) en les abaissant doucement aux niveaux appropriés sur l'établi, comme illustré.

ADDITIONNEL : Insérez des chevilles (S2) dans la paroi perforée (Q) pour accrocher les outils.

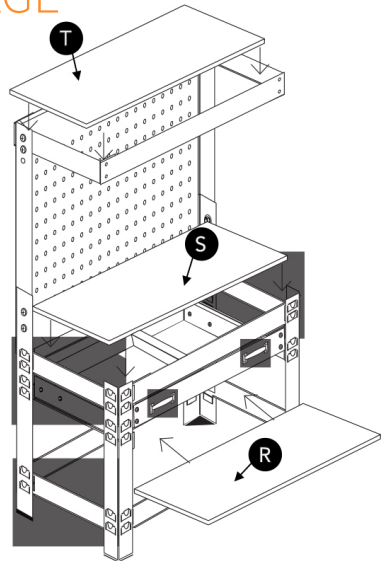

DÉPANNAGE

GUIDE DE RÉOLUTION

QUE DOIS-JE FAIRE S'IL MANQUE DES PIÈCES DANS MA COMMANDE ?

S'il semble qu'il manque une pièce à votre commande, contactez notre équipe d'assistance à la clientèle, aimable et serviable, dans les 7 jours suivant la réception.

POUR TOUTE AUTRE QUESTION, VEUILLEZ CONTACTER NOTRE ÉQUIPE D'ASSISTANCE À LA CLIENTÈLE.



SPEZIFIKATIONEN

PRODUKTBESCHREIBUNG

Unsere Werkbank mit Schublade ist die perfekte Lösung für Ihre Lageranforderungen. Mit ihrer großen unteren Ablagefläche, dem robusten Arbeitsbereich, der praktischen Schublade und der oberen Ablagefläche bietet sie Ihnen reichlich Stauraum. So bleibt Ihre Garage blitzblank!

PRODUKTSPEZIFIKATIONEN

Breite:	120cm
Höhe:	150cm
Tiefe:	60cm
Kapazität ob. Regal:	30KG
Kapazität unt. Regal:	100KG
Kap. Arbeitsbereich:	200KG
Kapazität Schublade:	40KG

PRODUKTEIGENSCHAFTEN

- A. Oberes Regal
- B. Unteres Regal
- C. Schublade
- D. Arbeitsbereich
- E. Pinnwand



SPEZIFIKATIONEN

LISTE DER TEILE

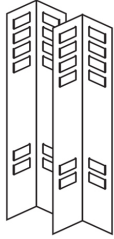

A Vordere Beine- x2



B Hint. link. Bein- x1



C Hint. rech. Bein- x1

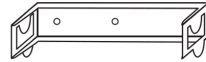

D Linke Schubladenstütze- x1

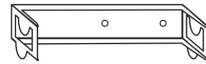

E Rechte Schubladenstütze- x1

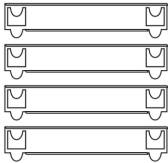

F Kurze Arbeitsplatte halterung- x4

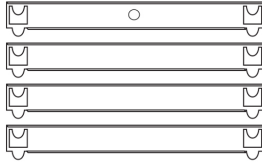

G Lange Arbeitsplatte halterung- x4



H Linke vertikale Stütze- x1



I Rechte vertikale Stütze- x1



J1 Rückenstütze

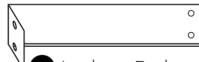

K L. obere Fachbodenstütze - x1

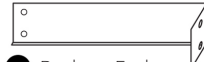

L R. obere Fachbodenstütze - x1



J2 Vordere Stütze

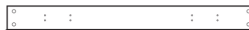

M Schubladenfront- x1



N Rückseite Schublade- x1



O Schubladenseiten (kurz) - x2



P Schubladenboden- x1

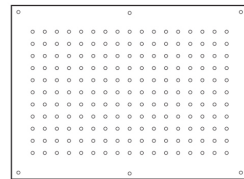

Q Pinwand - x1

Die Haftung von Monster Group UK Limited ist auf den Handelswert des Produkts beschränkt.

SPEZIFIKATIONEN

LISTE DER TEILE



R Unteres Regal - x1



S Arbeitsfläche - x1

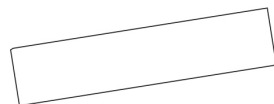

T Oberes Regal - x1



V Kurze Befestigungen - x30



W Lange Befestigungen - x6



X Muttern/Schrauben (klein) - x16

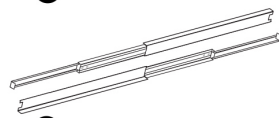

U Schubladenschienen - x2



Y Pinnwandstütze - x1

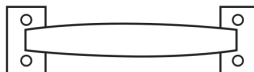

S1 Schubladengriffe - x2



S2 Stifte - x40



S3 Kappenfüße - x4

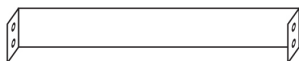

S4 Schubladenstütze - x1

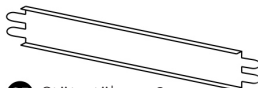

S5 Stützstäbe - x2



Z Gummihammer - x1



S6 Stützstäbe - x4

SICHERHEITSHINWEISE

SICHERES ARBEITEN

- Befolgen Sie beim Zusammenbau dieses Produkts die mitgelieferten Anweisungen.
- Vergewissern Sie sich, dass Sie die Anweisungen und Sicherheitshinweise vollständig verstanden haben, bevor Sie mit der Montage beginnen.
- Verwenden Sie dieses Produkt nur für den vorgesehenen Verwendungszweck.
- Halten Sie das Gewicht immer gleichmäßig verteilt, um Beschädigungen an der Werkbank oder der MDF zu vermeiden und um zu verhindern, dass die Werkbank umfällt.
- Modifizieren oder verändern Sie dieses Produkt in keiner Weise.
- Wir empfehlen, einen qualifizierten Fachmann mit dem Zusammenbau und/oder der Installation der Werkbank zu beauftragen.
- Halten Sie Ihren Montagebereich sauber.
- Verwenden Sie dieses Produkt auf einer ebenen Oberfläche.
- Achten Sie darauf, dass Kinder, Haustiere/Tiere und unerfahrene Benutzer nicht in der Nähe sind, wenn Sie das Produkt zusammenbauen.
- Überschreiten Sie nicht die in den Produktspezifikationen auf Seite 2 angegebene Belastbarkeit.
- Überprüfen Sie das Produkt regelmäßig auf Schäden und Anzeichen von Verschleiß. Ziehen Sie alle Komponenten fest, die lose zu sein scheinen.
- Stellen Sie sicher, dass die Formfüße korrekt angebracht sind, um mögliche Verletzungen zu vermeiden.
- Behandeln Sie die MDF-Platten mit Lack oder Schimmelvernichter, wenn sie in einem feuchten Umfeld arbeiten.
- Wir empfehlen zwei Personen für die Montage des Produkts.

BENUTZERGUIDE

MONTAGEANLEITUNG

Um Platz für den sicheren Sitz der Laschen zu schaffen, empfiehlt es sich, die Laschen mit einem geeigneten Schlitzschraubendreher (nicht mitgeliefert) vorsichtig aufzudrücken. Nach dem Einsetzen der Laschen mit einem geeigneten Gummihammer vorsichtig zuschlagen, um sie zu sichern.

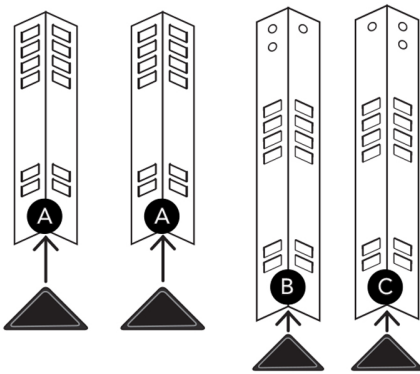

SCHRITT 1:

Stecken Sie die 4 Kappenfüße (S3) wie abgebildet auf die Enden der Beine (A, B, C).

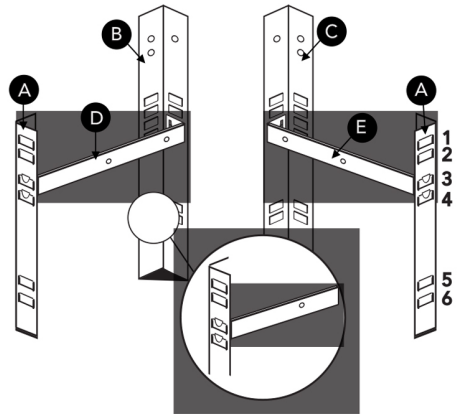

SCHRITT 2:

Bringen Sie die Schubladenstützen (D, E) zwischen den Vorder- und Hinterbeinen (A, B, C) an und befestigen Sie sie wie abgebildet.

Die Schubladenstützen sollten zwischen dem dritten und vierten Schlitz angebracht werden und nach außen zeigen.

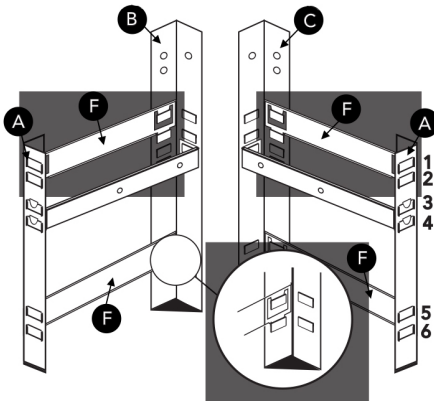

SCHRITT 3:

Bringen Sie die 4 Arbeitsplattenstützen (F) wie abgebildet an den Vorder- und Hinterbeinen (A, B, C) an.

Die kurzen Arbeitsplattenstützen sollten zwischen dem ersten/zweiten und fünften/sechsten Schlitz positioniert werden.

BENUTZERGUIDE

MONTAGEANLEITUNG

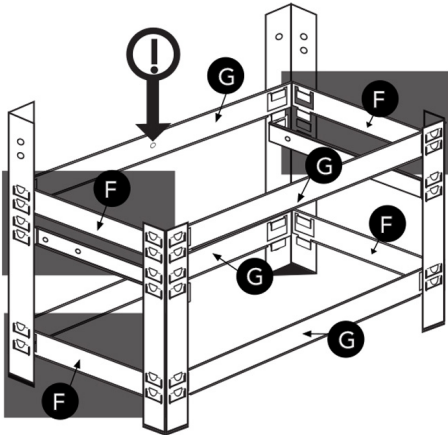

SCHRITT 4:

Bringen Sie die 4 langen Arbeitsplattenstützen (G) an den Vorder- und Hinterbeinen (A, B, C) am 1./2. und 5./6. Schlitz an.

Die lange Arbeitsplattenstütze mit dem zentralen Loch sollte zwischen dem ersten und zweiten Schlitz an den hinteren Beinen (B, C) positioniert werden.

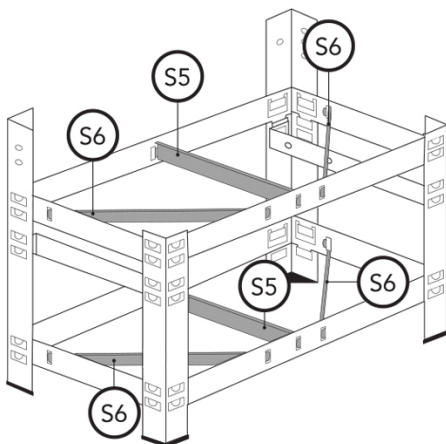

SCHRITT 4.1:

Bringen Sie die Stützen (S5 & S6) am Rahmen an.

SCHRITT 5:

Biegen Sie die Laschen an jedem Ende der Stützstäbe (S5) in einem Winkel von 90°. Positionieren Sie die Schlitzte oben und unten und schieben Sie sie zwischen die vorderen und hinteren Seitenbalken (G).

Biegen Sie die Laschen zur Befestigung wieder auf sich selbst zurück (wie unten abgebildet).

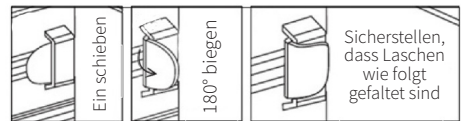

Bringen Sie die linke und rechte obere vertikale Stütze (H, I) an den Seiten der Hinterbeine (B, C) an.

Mit 4 kurzen Befestigungen (V) sichern.

Zur Sicherung mit einem geeigneten Schraubenschlüssel anziehen. Sichern Sie die Stützstäbe (S5) mit (W).

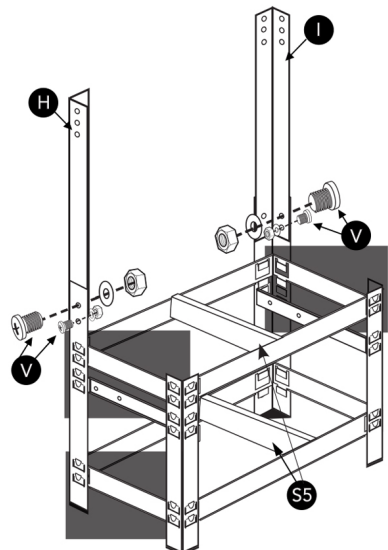

BENUTZERGUIDE

MONTAGEANLEITUNG

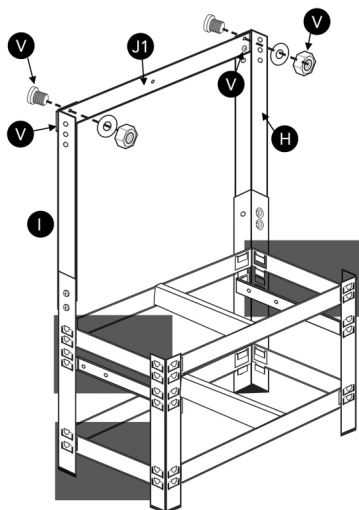

SCHRITT 6:

Befestigen Sie die Rückenstütze (J1) oben 2 Löcher der Vertikalstützen (H, I). Sichern mit 4 Kurzbefestigungen (V). Zur Sicherung festziehen.

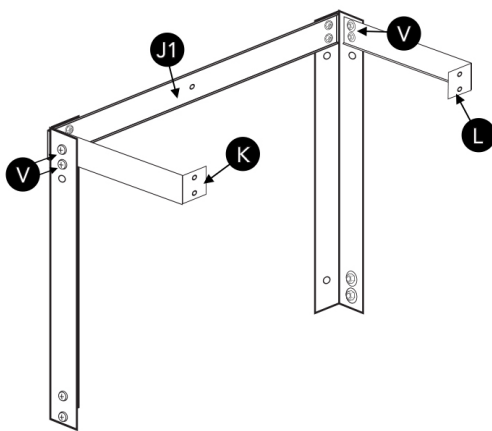

SCHRITT 7:

Befestigen Sie die längste Kante der kurzen oberen Fachbodenstützen (K, L) an den oberen 2 Löchern der vertikalen Stützen (H, I) mit 4 kurzen Befestigungen (V) wie abgebildet. Zur Sicherung festziehen.

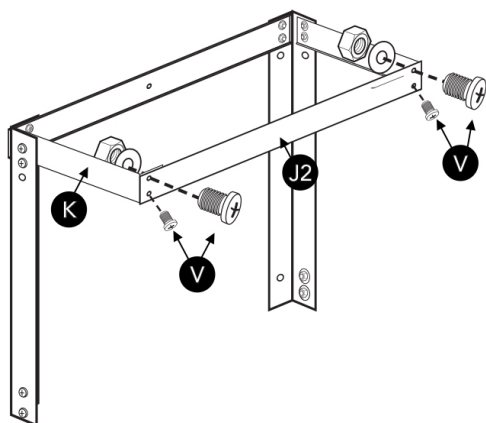

SCHRITT 8:

Befestigen Sie die vordere Stütze (J2) an der Vorderseite der kurzen oberen Fachbodenstützen (K, L) mit 4 kurzen Befestigungen (V) wie abgebildet. Zur Sicherung festziehen.

BENUTZERGUIDE

MONTAGEANLEITUNG

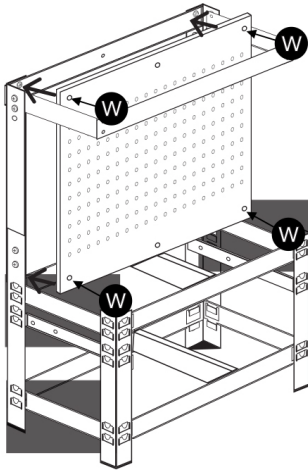

SCHRITT 9:
Befestigen Sie die Pinwand (Q) mit 4
langen Dübeln (W). Zum Sichern
festziehen.

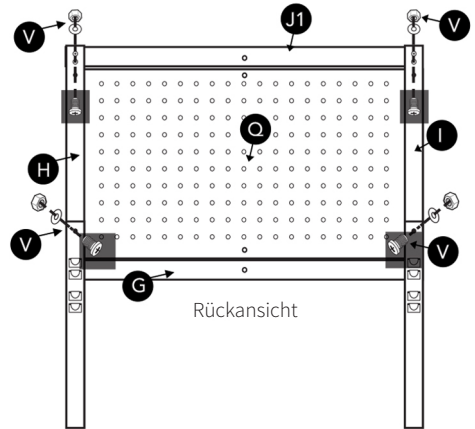

SCHRITT 10:
Führen Sie von hinten 4 kurze Dübel (V)
in die freien Löcher in den Vertikalstützen (H, I)
ein. Zur Befestigung anziehen.

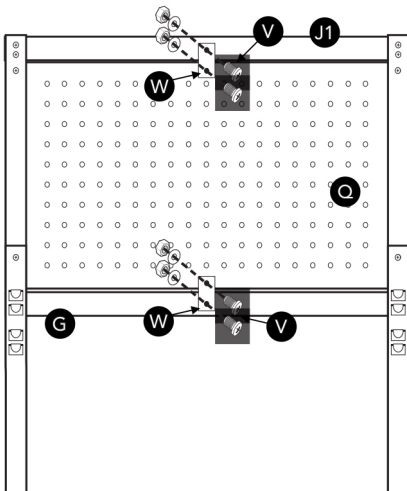

SCHRITT 11:
Befestigen Sie die Pinwandträger (Y) mit 2
kurzen Befestigungen (V) an der Rückseite
der Baugruppe durch die freien Löcher an
den langen Trägern (G, J1).

Stecken Sie 2 lange Befestigungen (W) in
die freien Löcher an den Pinwandträger
(Y) und in die Stecktafel (Q). Ziehen Sie alle
zur Befestigung an.

BENUTZERGUIDE

MONTAGEANLEITUNG

SCHRITT 12:

Befestigen Sie die 2 Schubladengriffe (S1) an der Schubladenfront (M), indem Sie 8 kleine Muttern/Schrauben (X) von außen nach innen in Richtung der Leiste einführen. Zur Sicherung festziehen.

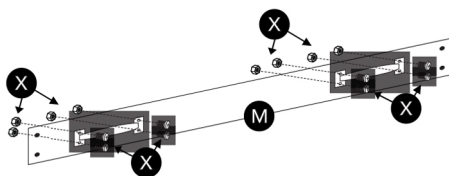

SCHRITT 13:

Befestigen Sie die kurzen Schubladenseiten (O) an der Schubladenfront (M), indem Sie 4 kurze Befestigungen (V) verwenden. Zur Sicherung festziehen.

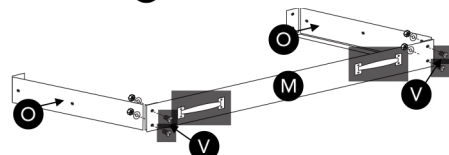

SCHRITT 14:

Senken Sie den Schubladenboden (P) in die Schubladenbaugruppe ab, so dass er auf den inneren Leisten aufliegt. Befestigen Sie die lange Schubladenrückwand (N) mit 4 kurzen Befestigungen (V) an der Baugruppe.

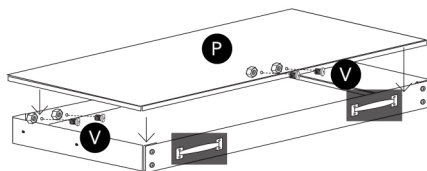

SCHRITT 15:

Befestigen Sie die 2 Schubladenschienen (U) an den kurzen Schubladenseiten (O) mit 4 kleinen Muttern/Schrauben (X) durch die verfügbaren Löcher wie abgebildet. Zur Sicherung festziehen.

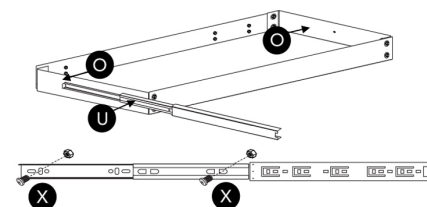

SCHRITT 16:

Halten Sie die Schublade innerhalb der Werkbankbaugruppe, fahren Sie die Schubladenschienen (U) aus und richten Sie sie mit den Befestigungslöchern in den Schubladenstützen (D, E) aus. Führen Sie 4 kleine Befestigungen (X) durch die Führungen und in die Halterungen ein. Zur Sicherung festziehen.

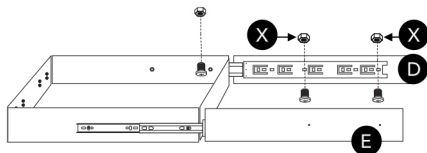

Setzen Sie die Schubladenstütze (S4) in die Mitte der Schublade ein und befestigen Sie sie mit (W).

BENUTZERGUIDE

MONTAGEANLEITUNG

SCHRITT 17:

Bringen Sie das obere Regal (T), die Arbeitsplatte (S) und das untere Regal (R) an, indem Sie sie vorsichtig in die entsprechenden Ebenen auf der Werkbank absenken (siehe Abbildung).

ZUSÄTZLICH: Setzen Sie Stifte (S2) in die Pinnwand (Q) ein, um Werkzeuge bequem aufzuhängen.

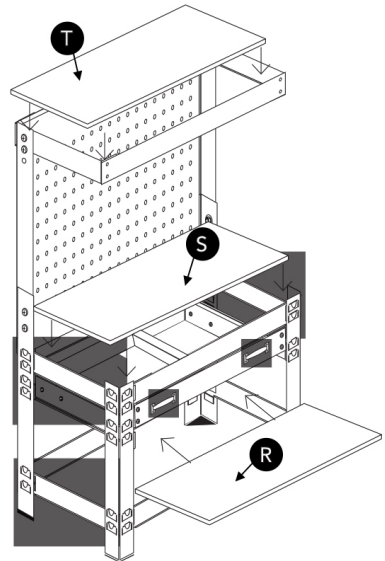

FEHLERBEHEBUNG

LÖSUNGSGUIDE

WAS TUE ICH, WENN IN MEINER BESTELLUNG ETWAS FEHLT?

Wenn bei Ihrer Bestellung ein Teil zu fehlen scheint, wenden Sie sich innerhalb von 7 Tagen nach Erhalt an unser freundliches und hilfsbereites Kundensupport-Team.

FÜR ALLE ANDEREN FRAGEN WENDEN SIE SICH BITTE AN UNSER KUNDENSUPPORT-TEAM.



ESPECIFICACIÓN

DESCRIPCIÓN DE PRODUCTO

Nuestra mesa de trabajo con cajón es la solución perfecta para sus necesidades de almacenamiento. ¡Gracias a su gran fondo inferior, su área de trabajo resistente, su práctico cajón y su repisa superior, su amplio espacio de almacenamiento mantendrá su garaje impecable!

ESPECIFICACIONES DEL PRODUCTO

Ancho:	120cm
Alto:	150cm
Profundidad:	60cm
Capacidad de repisa superior:	30KG
Capacidad del repisa inferior:	100KG
Capacidad del área de trabajo:	200KG
Capacidad del cajón:	40KG

CARACTERÍSTICAS DEL PRODUCTO

- A. Repisa Superior
- B. Repisa Inferior
- C. Cajón
- D. Área de Trabajo
- E. Tabla de Clavija



ESPECIFICACIÓN

LISTA DE PIEZAS

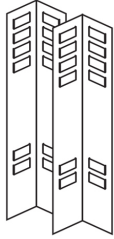

A Patas delanteras - x2



B Pata Trasera Izquierda - x1



C Pata Trasera derecho - x1

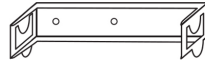

D Soporte del Cajón Izquierdo - x1

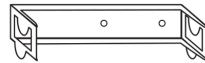

E Soporte del Cajón Derecho - x1

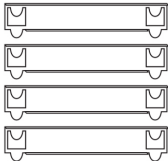

F Soportes cortos de encimera - x4

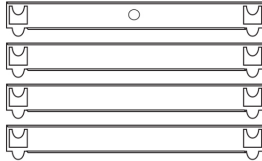

G Soportes largos de encimeras - x4



H Soporte Vertical izquierdo - x1



I Soporte Vertical Derecho - x1



J1 Soporte Trasero



K Soporte del estante superior izquierdo - x1



L Soporte de estante superior derecho x1



J2 Soporte Delantero



M Cajón delantero - x1



N Cajón trasero - x1



O Lados del cajón (cortos) - x2



P Base de Cajones - x1

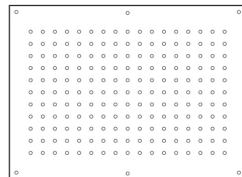

Q Tablero de clavijas x1

La responsabilidad de Monster Group UK Limited estará limitada únicamente al valor comercial del producto.

ESPECIFICACIONES

LISTA DE PIEZAS

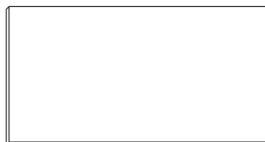

R Repisa Inferior - x1

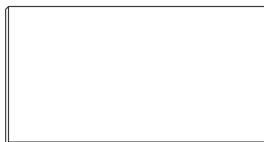

S Repisa - x1

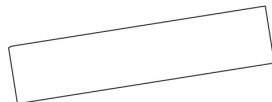

T Repisa Superior - x1



V Fijaciones cortas - x30

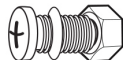

W Fijaciones largas - x6



X Tuercas/Pernos (Pequeño) - x16

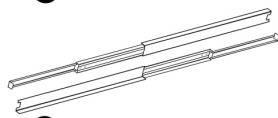

U Corredores de cajones - x2

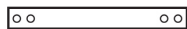

Y Soporte de tablero de clavijas - x1

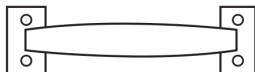

S1 Manijas de cajón - x2



S2 Clavijas - x40



S3 Tapas de pies x4



S4 Soporte de Cajón - x1



S5 Soporte de Barras - x2

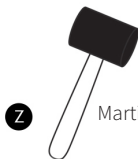

Z Martillo de Goma - x1



S6 Soporte de Barras - x4

CONSEJO DE SEGURIDAD

PRACTICA DE TRABAJO SEGURA

- Siga las instrucciones proporcionadas al ensamblar este producto.
- Asegúrese de haber entendido por completo las instrucciones y consejos de seguridad antes de continuar con el ensamble.
- No use este producto para otra cosa que no sea su uso previsto.
- Mantenga siempre el peso distribuido uniformemente para evitar daños a la mesa de trabajo o MDF para evitar que la mesa de trabajo se caiga.
- Por lo tanto, no altere ni modifique este producto de ninguna manera.
- Recomendamos contratar a un profesional calificado para ensamblar y / o instalar la mesa de trabajo.
- Mantenga su área de ensamble libre de desorden.
- Use este producto sobre una superficie plana.
- Asegúrese de que los niños, mascotas / animales y usuarios inexpertos no estén cerca cuando construyendo este banco de trabajo.
- No exceda la capacidad de carga mostrada en las especificaciones del producto en la página 2.
- Inspeccione regularmente el producto en busca de daños y signos de desgaste. Apriete cualquier componente que parezca estar suelto.
- Asegúrese de que las patas moldeadas estén unidas correctamente para evitar posibles lesiones.
- Trate los tableros de MDF con barniz o productos para prevenir el moho si los usa en un ambiente húmedo.
- Recomendamos que dos personas monten el producto.

GUIA DE USUARIO

INSTRUCCIONES DE ARMADO

Para dejar espacio para que las pestañas encajen de forma segura, se recomienda que abra suavemente las pestañas con un destornillador de cabeza plana adecuado (no suministrado). Una vez que se han insertado las pestañas, cierre suavemente con un mazo de goma adecuado para asegurar.

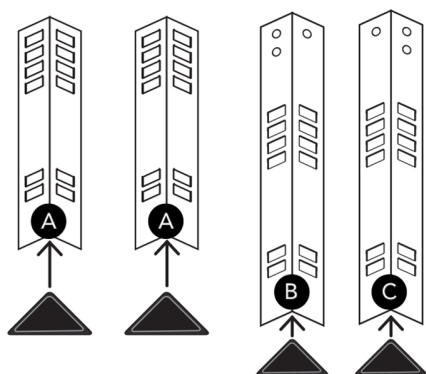

PASO 1:

Sujete las 4 tapas de pie (S3) en los extremos de las patas (A, B, C) como se ilustra.

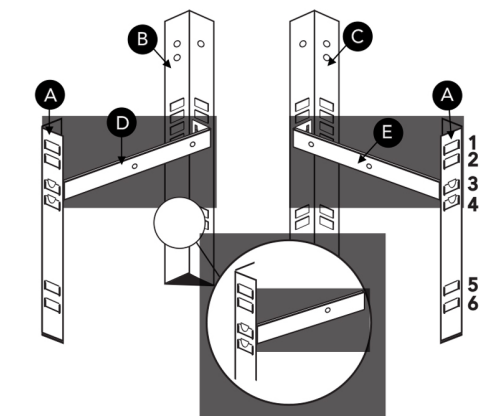

PASO 2:

Coloque los soportes de cajón (D, E) entre las patas delanteras y traseras (A, B, C) y fijela como se ilustra.

Los soportes para cajón deben colocarse entre la tercera y cuarta ranura y mirar hacia atrás.

PASO 3:

Coloque los 4 soportes de repisa (F) en las patas delanteras y traseras (A, B, C) como se ilustra.

Los soportes de repisa deben colocarse entre las ranuras 1^a / 2^a y 5^a / 6^a.

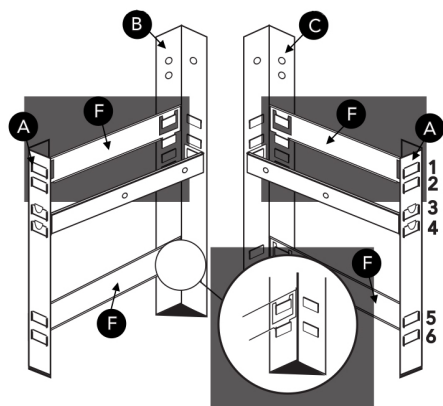

GUIA DE USUARIO

INSTRUCCIONES DE ARMADO

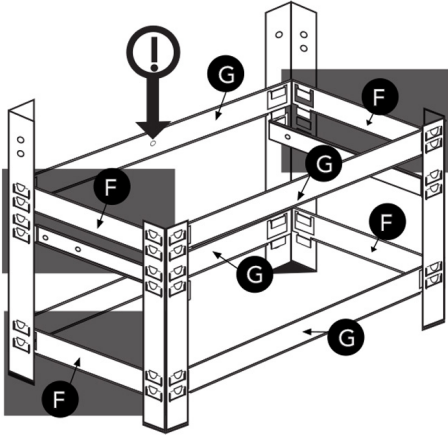

PASO 4:

Coloque los 4 soportes largos de la repisa (G) en las patas delanteras y traseras (A, B, C) en las ranuras primera / segunda y quinta / sexta.

El soporte largo de la repisa con el orificio central debe colocarse entre las ranuras 1ª / 2ª en las patas traseras (B, C).

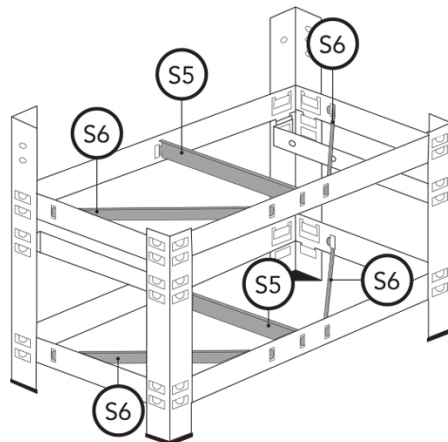

PASO 4.1:

Ajustar los soportes (S5 y S6) al marco.

PASO 5:

Doble las pestañas en cada extremo de las barras de soporte (S5) en un ángulo de 90°. Ubique las ranuras en la parte superior e inferior y colóquelas en su lugar entre las vigas laterales delanteras y traseras (G).

Doble las pestañas sobre sí mismas (como se muestra a continuación) para unir.

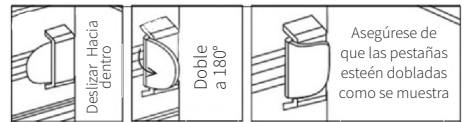

Coloque los soportes verticales superiores izquierdo y derecho (H, I) en los lados de las patas traseras (B, C).

Asegure con 4 fijaciones cortas (V).

Apriete con una llave adecuada para asegurar. Asegure las barras de soporte (S5) en su lugar con (W).

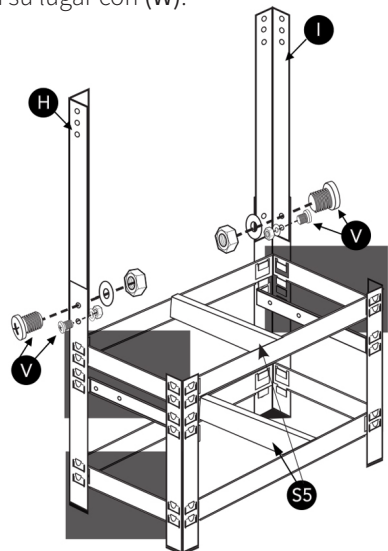

GUIA DE USUARIO

INSTRUCCIONES DE ARMADO

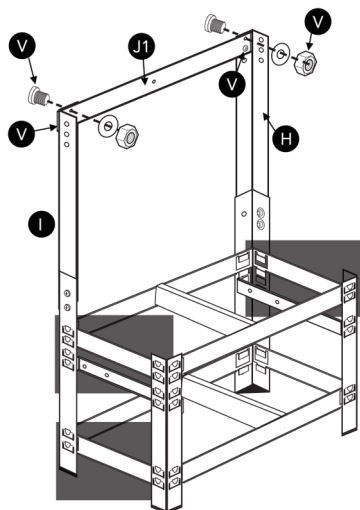

PASO 6:
Fije el soporte posterior (J1) en la parte superior 2 agujeros de los soportes verticales (H, I). Asegure con 4 fijaciones cortas (V). Apriete para asegurar.

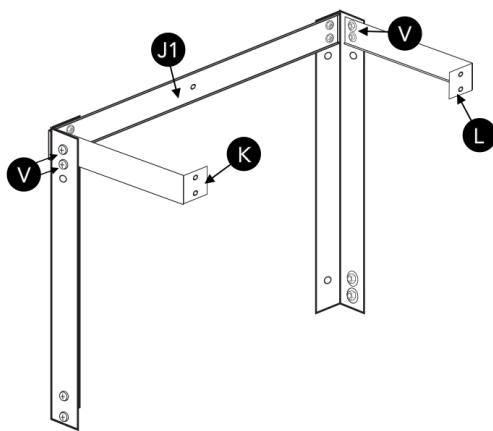

PASO 7:
Fije el borde más largo de los soportes de estante superior cortos (K, L) a los 2 orificios superiores de los soportes verticales (H, I) con 4 fijaciones cortas (V) como se ilustra. Apriete para asegurar.

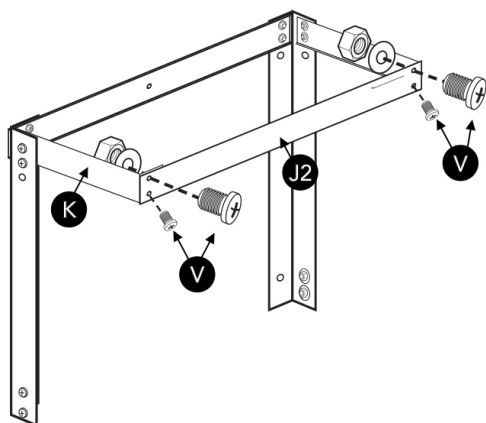

PASO 8:
Fije el soporte frontal (J2) al frente de los soportes de estante superior cortos (K, L) utilizando 4 fijaciones cortas (V) como se ilustra. Apriete para asegurar.

GUIA DE USUARIO

INSTRUCCIONES DE ARMADO

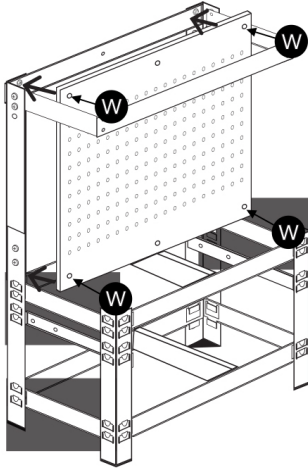

PASO 9:
Fije el tablero de clavijas (Q) con 4 fijaciones largas (W). Apriete para asegurar.

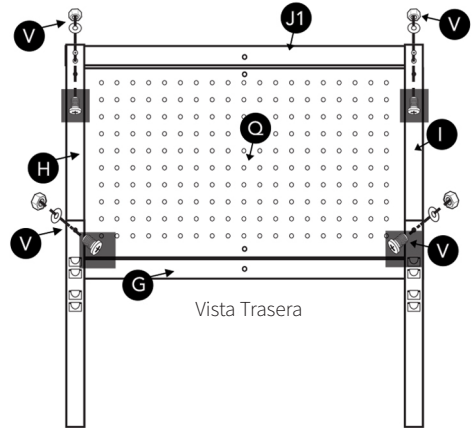

PASO 10:
Desde la parte posterior, inserte 4 fijaciones cortas (V) en los agujeros vacíos en los soportes verticales (H, I). Apriete para asegurar.

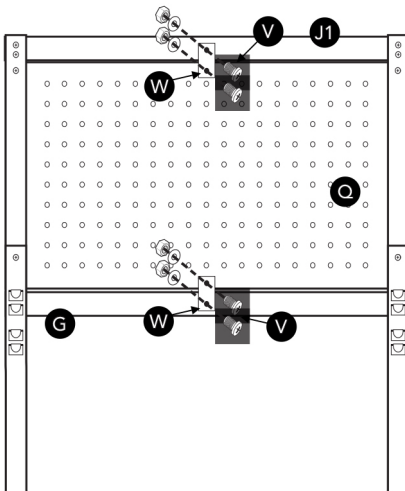

PASO 11:
Usando 2 fijaciones cortas (V), fije los soportes de tablero (Y) en la parte posterior del conjunto a través de los agujeros vacíos en los soportes largos (G, J1).

Inserte 2 fijaciones largas (W) en los agujeros vacíos en los soportes del tablero (Y) y en el tablero (Q). Apriete todo para asegurar.

GUIA DE USUARIO

INSTRUCCIONES DE ARMADO

PASO 12:

Fije las 2 manijas del cajón (S1) al frente del cajón (M) insertando 8 tuercas / pernos pequeños (X) desde el exterior hacia la repisa. Apriete para asegurar.

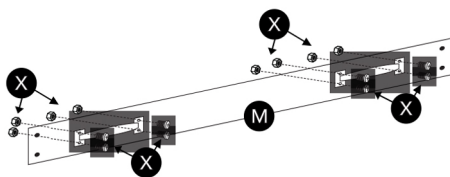

PASO 13:

Fije los lados cortos del cajón (O) al frente del cajón (M) con 4 fijaciones cortas (V). Apriete para asegurar.

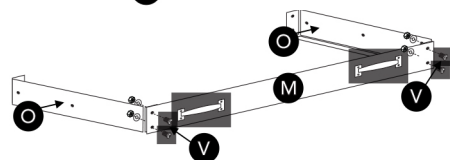

PASO 14:

Baje la base del cajón (P) en el ensamblaje del cajón para descansar sobre las repisas internas. Fije la parte posterior larga del cajón (N) al ensamblaje usando 4 fijaciones cortas (V).

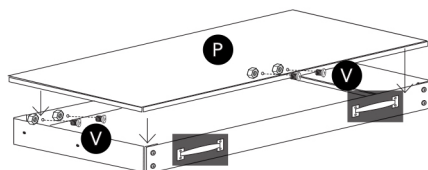

PASO 15:

Fije los 2 corretores del cajón (U) a los lados cortos del cajón (O) usando 4 tuercas / pernos pequeños (X) a través de los agujeros disponibles como se ilustra. Apriete para asegurar.

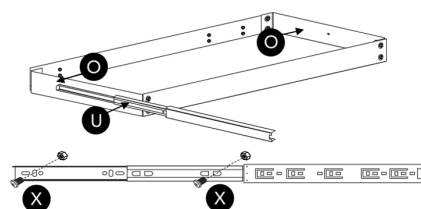

PASO 16:

Sosteniendo el cajón dentro del ensamblaje de la mesa de trabajo, extienda y alinee los corretores del cajón (U) con los agujeros de fijación en los soportes del cajón (D, E). Inserte 4 pequeñas fijaciones (X) a través de los corretores y en los soportes. Apriete para asegurar.

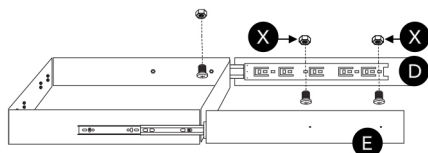

Inserte el soporte del cajón (S4) en el centro del cajón y fíjelo en su lugar con (W).

GUIA DE USUARIO

INSTRUCCIONES DE ARMADO

PASO 17:

Ajuste el estante superior (T), la repisa (S) y el estante inferior (R) bajándolos suavemente a los niveles apropiados en la mesa de trabajo como se ilustra.

ADICIONAL: Inserte las Clavijas (S2) en el tablero (Q) para colgar las herramientas para mayor comodidad.

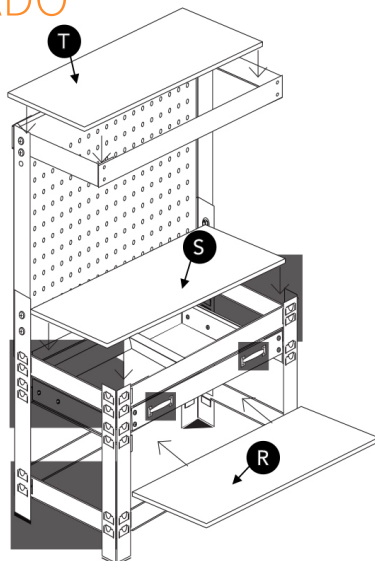

SOLUCIÓN DE PROBLEMAS

GUÍA DE RESOLUCIÓN

¿QUÉ HAGO SI HAY PIEZAS FALTANTES DE MI PEDIDO?

Si parece que falta alguna pieza en su pedido, comuníquese con nuestro Equipo de Atención al Cliente amable y servicial dentro de los 7 días posteriores a la recepción.

PARA TODAS LAS OTRAS CUESTIONES, CONTACTE A NUESTRO EQUIPO DE APOYO AL CLIENTE.

SPECIFICHE

DESCRIZIONE DEL PRODOTTO

Il nostro Banco da Lavoro con Cassetto rappresenta la soluzione ideale per riporre tutti i tuoi oggetti. Grazie al suo ampio ripiano inferiore, all'area di lavoro robusta, al maneggevole cassetto, al ripiano superiore e alla sua ampia capacità di contenere oggetti ti aiuterà a mantenere il tuo garage pulito e ordinato!

SPECIFICHE DEL PRODOTTO

Larghezza:	120cm
Altezza:	150cm
Profondità:	60cm
Capacità Ripiano Alto:	30KG
Capacità Ripiano Basso:	100KG
Capacità Bancone:	200KG
Capacità Cassetto:	40KG

CARATTERISTICHE DEL PRODOTTO

- A. Ripiano Superiore
- B. Ripiano Inferiore
- C. Cassetto
- D. Area di Lavoro
- E. Pannello Forato



SPECIFICHE

ELENCO DELLE PARTI

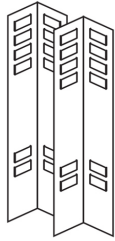

A Gambe Anteriori - x2



B Gamba Sinistra Posteriore - x1



C Gamba Destra Posteriore - x1



D Supporto Sinistro per il Cassetto - x1

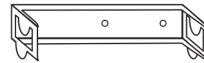

E Supporto Destro per il Cassetto - x1

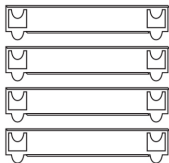

F Supporti Corti per il Piano di Lavoro - x4

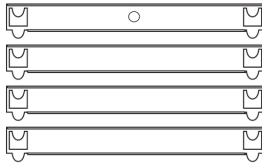

G Supporti Lunghi per il Piano di Lavoro - x4



H Supporto Verticale Sinistro - x1



I Supporto Verticale Destro - x1

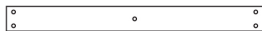

J1 Supporto Posteriore



K Supporto Sinistro per il Ripiano Superiore - x1



L Supporto Destro per il Ripiano Superiore - x1



J2 Supporto Frontale



M Parte Frontale del Cassetto - x1



N Parte Posteriore del Cassetto - x1

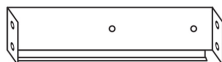

O Lati del Cassetto (Corti) - x2



P Base del Cassetto - x1

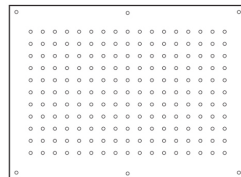

Q Pannello Forato - x1

La responsabilità di Monster Group UK Limited sarà limitata al solo valore commerciale del prodotto.

SPECIFICATION

PARTS LIST



R Ripiano Inferiore - x1



S Piano di Lavoro - x1

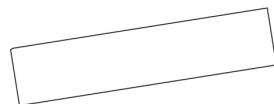

T Ripiano Superiore - x1



V Fissaggi Corti - x30

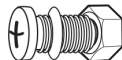

W Fissaggi Lunghi - x6



X Dadi/Bulloni (Piccoli) - x16

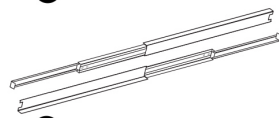

U Binari per il Cassetto - x2



Y Supporti del Pannello Forato - x1



S1 Maniglie dei Cassetti - x2



S2 Pioli - x40



S3 Coperture per i Piedi - x4

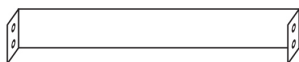

S4 Supporto per il Cassetto - x1



S5 Barre di Supporto - x2

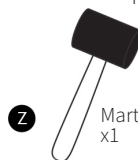

Z Martello di Gomma - x1



S6 Barre di Supporto - x4

CONSIGLI PER LA SICUREZZA

PRATICHE DI LAVORO SICURE

- Durante il montaggio di questo prodotto, seguire con attenzione le istruzioni fornite.
- Assicurarsi di aver compreso completamente le istruzioni e i consigli sulla sicurezza prima di procedere con il montaggio.
- Non utilizzare questo prodotto per scopi diversi da quelli previsti.
- Mantenere sempre il peso uniformemente distribuito per evitare danni al banco di lavoro o all'MDF e per evitare che il banco di lavoro possa cadere.
- Non alterare o modificare questo prodotto in nessun modo.
- Si consiglia far assemblare e/o installare questo banco da lavoro ad un professionista qualificato.
- Mantenere l'area di assemblaggio libera dal disordine.
- Utilizzare questo prodotto su una superficie piana.
- Assicurarsi che bambini, animali domestici e utenti inesperti non si trovino nelle vicinanze quando si monta questo banco di lavoro.
- Non superare la capacità di carico indicata nelle specifiche del prodotto a pagina 2.
- Ispezionare regolarmente il prodotto per verificare eventuali danni e segni di usura. Stringere tutti i componenti che appaiono allentati.
- Accertarsi che i piedini stampati siano correttamente fissati per evitare potenziali lesioni.
- Trattare i ripiani MDF con vernici o prodotti antimuffa se si utilizza il prodotto in ambienti umidi.
- Consigliamo che il prodotto venga assemblato da due persone.

GUIDA UTENTE

ISTRUZIONI DI MONTAGGIO

Al fine di fare in modo che vi sia spazio per le linguette così da poterle inserire in modo sicuro, si consiglia di aprire le linguette facendo delicatamente leva con un cacciavite a testa piatta adatto (non fornito). Dopo aver inserito le linguette, battere delicatamente con un martello di gomma adatto per chiuderle.

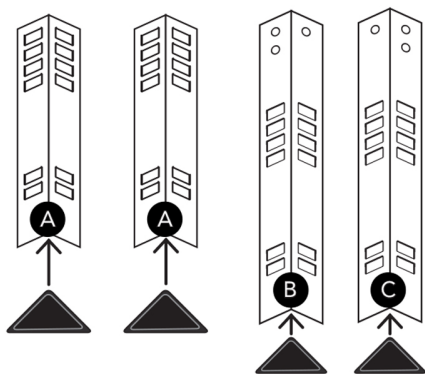

PASSO 1:

Agganciare i 4 Piedini (S3) alle estremità delle Gambe (A, B, C) come illustrato.

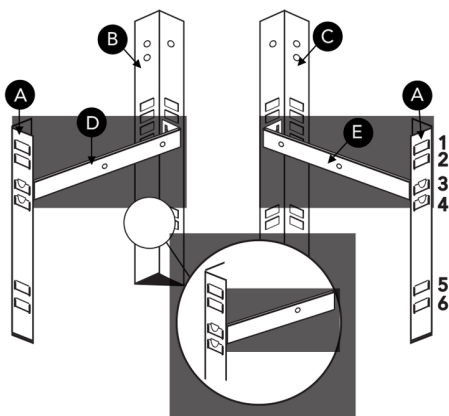

PASSO 2:

Montare i Supporti dei Cassetti (D, E) tra le Gambe Anteriore e Posteriore (A, B, C) e fissarli come illustrato.

I Supporti del Cassetto devono essere montati tra la 3a e la 4a fessura e rivolti verso l'esterno.

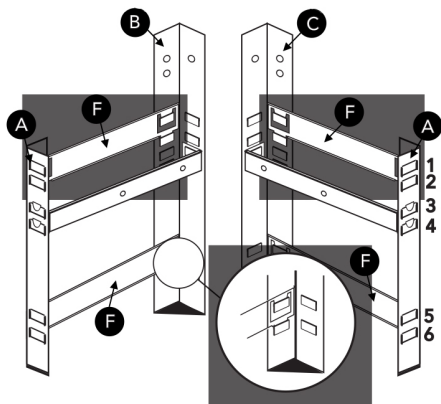

PASSO 3:

Montare i 4 Supporti del Piano di Lavoro (F) sulle Gambe Anteriore e Posteriore (A, B, C) come illustrato.

I supporti corti per il piano di lavoro devono essere posizionati tra la 1a/2a e la 5a/6a fessura.

GUIDA UTENTE

ISTRUZIONI DI MONTAGGIO

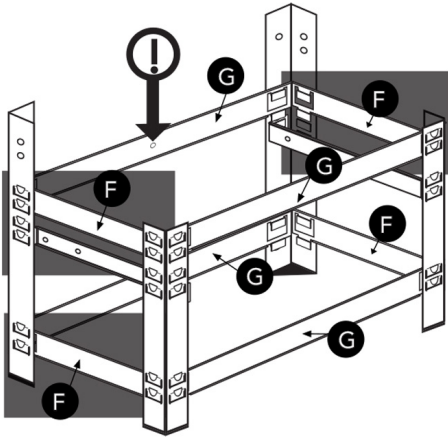

PASSO 4:

Montare i 4 Supporti Lunghi per il Piano di Lavoro (G) sulle gambe anteriore e posteriore (A, B, C) nelle fessure 1a/2a e 5a/6a.

Il Supporto Lungo per il Piano di Lavoro con il foro centrale deve essere posizionato tra la 1a/2a fessura sulle Gambe Posteriori (B, C).

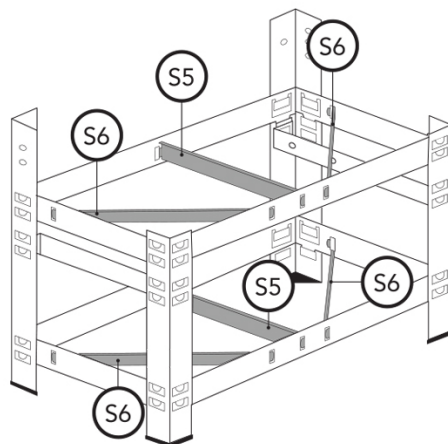

PASSO 4.1:

Inserisci i supporti (S5 & S6) nel telaio.

PASSO 5:

Piegare le linguette su ciascuna estremità delle Barre di Supporto (S5) con un angolo di 90°. Individuare le fessure sulla parte superiore e inferiore e posizionarle tra le Barre Anteriore e Posteriore (G).

Piegare di nuovo le linguette su se stesse (come mostrato sotto) per fissarle.

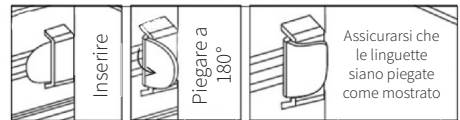

Montare i Supporti Verticali Superiori Sinistro e Destro (H, I) sui lati delle Gambe Posteriori (B, C).

Fissare utilizzando i 4 Fissaggi Corti (V).

Stringere con una chiave adatta per fissare il tutto. Fissare le barre di supporto (S5) in posizione utilizzando (W).

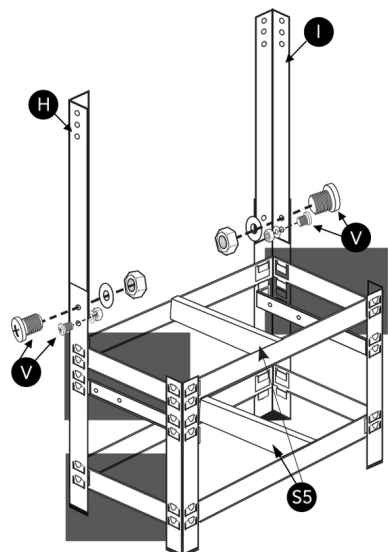

GUIDA UTENTE

ISTRUZIONI DI MONTAGGIO

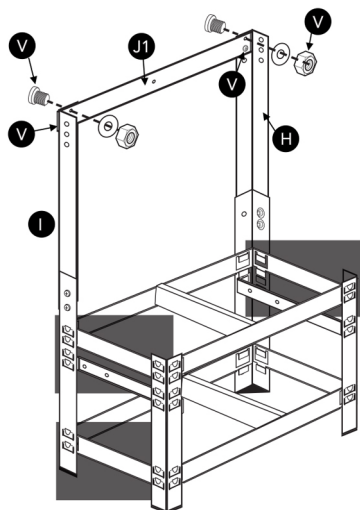

PASSO 6:
Fissare il Supporto Posteriore (J1) sui 2 fori in alto dei Supporti Verticali (H, I). Fissare il tutto con 4 Fissaggi Corti (V). Stringere per fissare.

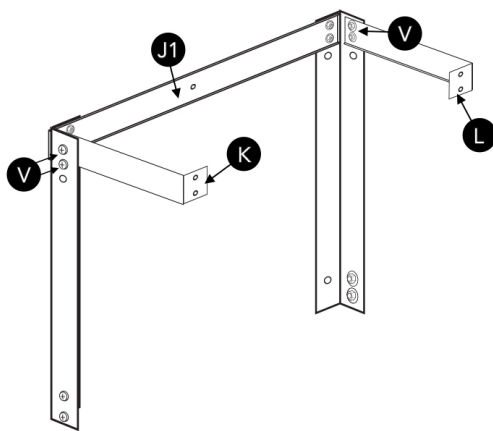

PASSO 7:
Fissare il bordo più lungo dei Supporti Corti del Ripiano Superiore (K, L) ai 2 fori superiori dei Supporti Verticali (H, I) utilizzando 4 Fissaggi Corti (V) come illustrato. Stringere per fissare.

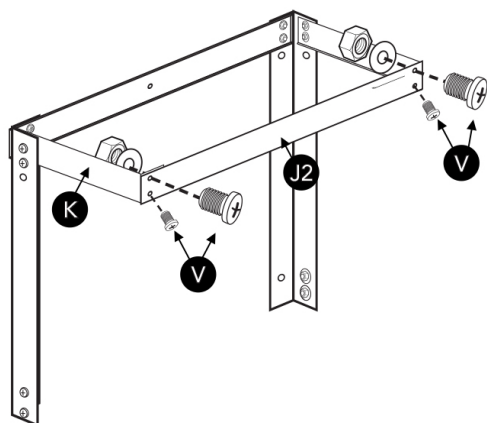

PASSO 8:
Fissare il Supporto Anteriore (J2) alla parte anteriore dei Supporti Corti del Ripiano Superiore (K, L) usando 4 Fissaggi Corti (V) come illustrato. Stringere per fissare.

GUIDA UTENTE

ISTRUZIONI DI MONTAGGIO

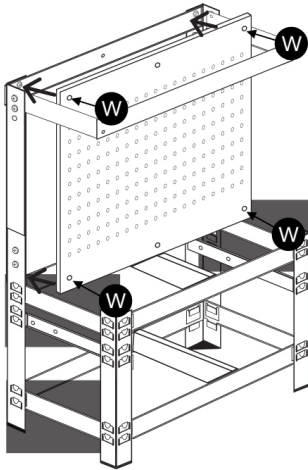

PASSO 9:
Fissare il Pannello Forato (Q) con 4 Fissaggi Lunghi (W). Stringere per fissare.

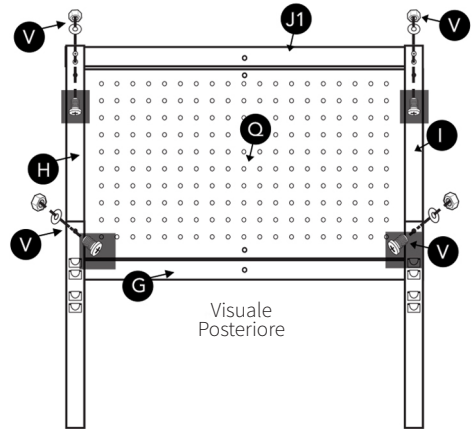

PASSO 10:
Dal retro, inserire 4 fissaggi corti (V) nei fori vuoti dei Supporti Verticali (H, I). Stringere per fissare.

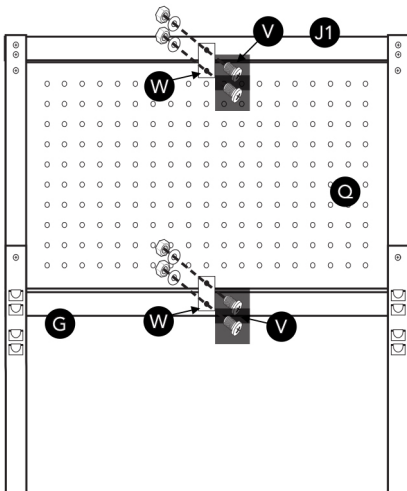

PASSO 11:
Utilizzando 2 Fissaggi Corti (V), attaccare i Supporti del Pannello Forato (Y) alla parte posteriore della parte assemblata utilizzando i fori vuoti sui Supporti Lunghi (G, J1).

Inserire 2 Fissaggi Lunghi (W) nei fori vuoti sui Supporti del Pannello Forato (Y) e nel Pannello Forato (Q). Stringere il tutto per fissare.

GUIDA UTENTE

ISTRUZIONI DI MONTAGGIO

PASSO 12:

Fissare le 2 Maniglie dei Cassetti (**S1**) sulla parte Frontale del Cassetto (**M**) inserendo 8 Dadi/Bulloni Piccoli (**X**) dall'esterno verso la sporgenza. Stringere per fissare.

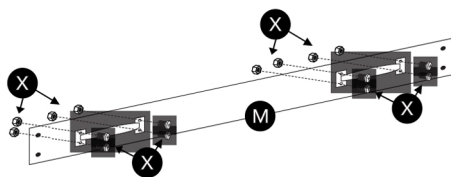

PASSO 13:

Fissare i Lati Corti del Cassetto (**O**) sul lato Frontale del Cassetto (**M**) utilizzando 4 Fissaggi Corti (**V**). Stringere per fissare.

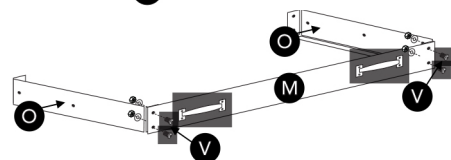

PASSO 14:

Posizionare la Base del Cassetto (**P**) nell'assemblaggio del cassetto per assestare le sporgenze interne. Fissare il Retro Lungo del Cassetto (**N**) all'assemblaggio utilizzando 4 Fissaggi Corti (**V**).

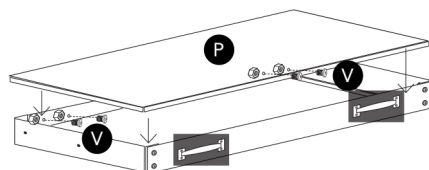

PASSO 15:

Fissare i 2 binari del cassetto (**U**) sui Lati Corti del Cassetto (**O**) utilizzando 4 Dadi/Bulloni Piccoli (**X**) attraverso i fori disponibili, come illustrato. Stringere per fissare.

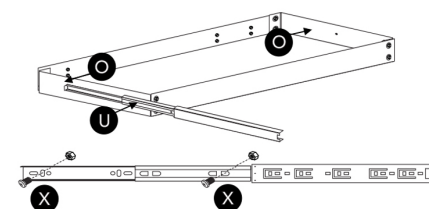

PASSO 16:

Tenendo il cassetto all'interno dell'assemblaggio del Banco di Lavoro, estendere e allineare i Binari del Cassetto (**U**) con i fori di fissaggio nei Supporti del Cassetto (**D, E**). Inserire 4 Fissaggi Piccoli (**X**) attraverso i Binari e nei Supporti. Stringere per fissare.

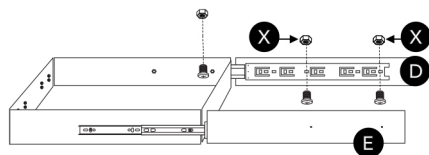

Inserire il Supporto del Cassetto (**S4**) al centro del cassetto e fissarlo in posizione utilizzando (**W**).

GUIDA UTENTE

ISTRUZIONI DI MONTAGGIO

PASSO 17:

Montare il Ripiano Superiore (T), il Piano di Lavoro (S) e il Ripiano Inferiore (R) posizionandoli delicatamente nei livelli appropriati sul banco di lavoro, come illustrato.

AGGIUNTIVO: Inserire i Pioli (S2) nel Pannello Forato (Q) per appendere gli strumenti in tutta comodità.

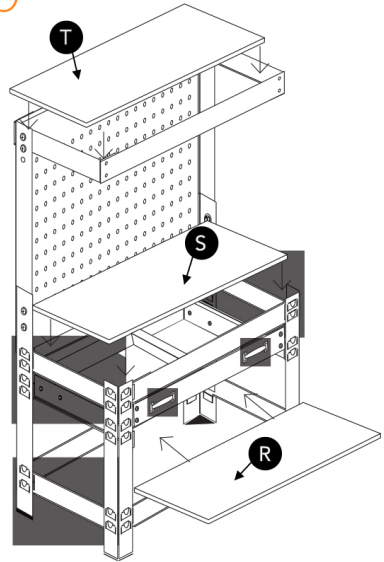

RISOLUZIONE DEI PROBLEMI

GUIDA ALLA RISOLUZIONE DEI PROBLEMI

COSA DEVO FARE SE CI SONO COMPONENTI MANCANTI NEL MIO ORDINE?

Se sembra che nel tuo ordine manchi qualche componente, contatta il nostro gentile Team di Supporto Clienti entro 7 giorni dalla ricezione del pacco.

PER QUALUNQUE ALTRO PROBLEMA, CONTATTA IL NOSTRO TEAM DI SUPPORTO CLIENTI.

SPECIFICATIES

PRODUCT OMSCHRIJVING

Deze werkbank met lade is de perfecte oplossing voor al uw opslagbehoeften. Met zijn grote onderste plank, stevige werkruimte, handige lade en bovenste plank, is er voldoende opbergruimte om je garage overzichtelijk en opgeruimd te houden!

PRODUCT SPECIFICATIES

Breed:	120cm
Hoog:	150cm
Diep:	60cm
Bovenste Plank capaciteit:	30KG
Onderste Plank capaciteit:	100KG
Capaciteit Werkruimte:	200KG
Capaciteit Lade:	40KG

PRODUCT EIGENSCHAPPEN

- A. Bovenste Plank
- B. Onderste Plank
- C. Lade
- D. Werkruimte
- E. Ophangbord



SPECIFICATIES

ONDERDELEN LIJST

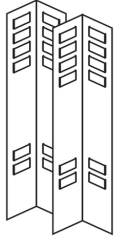

A Poten voorkant - x2



B Poot links achter - x1



C Poot rechts achter - x1

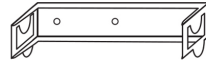

D Linker lade steun - x1

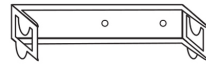

E Rechter lade steun - x1

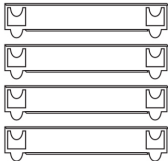

F Korte werkbank Steunen - x4

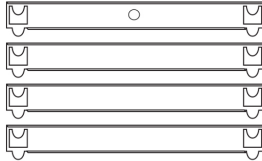

G Lange werkbank Steunen - x4



H Linker Verticale Steun - x1



I Rechter Verticale Steun - x1



J1 Steun Achterkant



K Bovenste plank Steun links - x1



L Bovenste plank Steun rechts - x1



J2 Steun voor

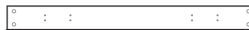

M Lade voorkant - x1



N Lade achterkant - x1

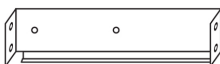

O Lade zijkant kort - x2



P Lade Bodem - x1

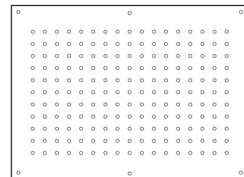

Q Ophangbord - x1

De aansprakelijkheid van Monster Group UK Limited is beperkt tot de commerciële waarde van het product.

SPECIFICATIES

ONDERDELEN LIJST



R Onderste plank - x1



S Werkbank - x1

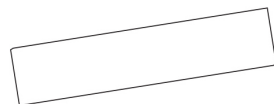

T Bovenste plank - x1



V Korte schroef - x30

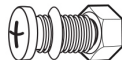

W Lange schroef - x6



X Moeren/bouten (Klein) - x16

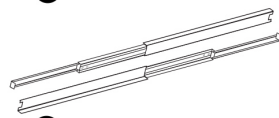

U Lade geleiders - x2



Y Ophangbord Steun - x1

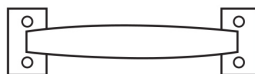

S1 Handgreep lade - x2



S2 Pinnen - x40



S3 Dopvoeten - x4

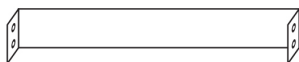

S4 Lade steun - x1



S5 Steunbalken - x2

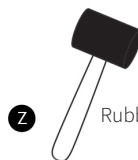

Z Rubber Hamer - x1



S6 Steunbalken - x4

VEILIGHEIDS ADVIES

VEILIG WERKEN

- Volg de instructies bij het monteren van dit product.
- Zorg ervoor dat u de instructies en het veiligheidsadvies volledig hebt gelezen voordat u doorgaat met de montage.
- Gebruik dit product niet voor iets anders dan waarvoor het bedoeld is.
- Houd het gewicht altijd gelijkmatig verdeeld om schade aan de werkbank of MDF te voorkomen en om te voorkomen dat de werkbank omvalt.
- Doe geen aanpassingen of maak geen wijzigingen aan dit product.
- We raden u aan een gekwalificeerde professional in te huren om de werkbank te monteren en / of te installeren.
- Houd uw montageplek vrij van rommel.
- Gebruik dit product op een vlakke ondergrond.
- Zorg ervoor dat kinderen, huisdieren en onervaren gebruikers niet in de buurt zijn wanneer u deze werkbank in elkaar zet.
- Overschrijd het draagvermogen - zoals aangegeven in de productspecificaties op pagina 2 - niet.
- Inspecteer het product regelmatig op schade en tekenen van slijtage. Draai alle componenten vast die lijken los te zitten.
- Zorg ervoor dat de voorgevormde dopvoeten correct zijn bevestigd om mogelijk letsel te voorkomen.
- Behandel de MDF-platen met vernis of schimmelpreventieproducten bij gebruik in een vochtige omgeving.
- We raden aan om met twee mensen het product te monteren.

HANDLEIDING

MONTAGE-INSTRUCTIES

Om ervoor te zorgen dat de lipjes goed passen, is het raadzaam de lipjes voorzichtig open te wrikken met een geschikte platte schroevendraaier (niet meegeleverd). Zodra de lipjes zijn geplaatst, tikt u deze voorzichtig dicht met een geschikte rubberen hamer om het vast te zetten.

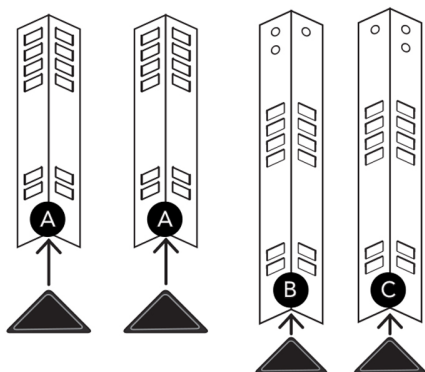

STAP 1:
Klem de 4 dopvoeten (S3) op de uiteinden van de poten (A, B, C) zoals afgebeeld.

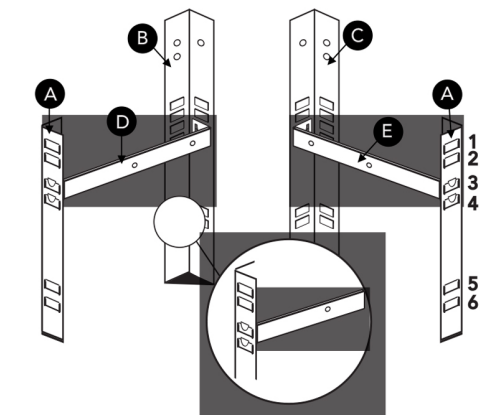
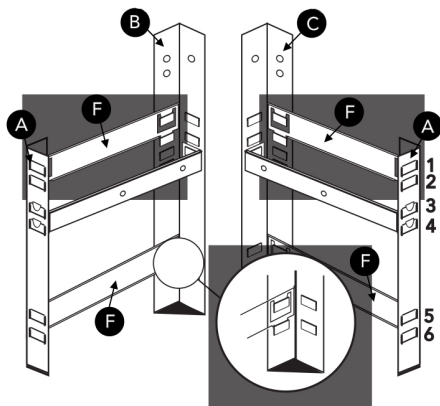

STAP 2:
Monteer de ladesteunen (D, E) tussen de voor- en achterpoten (A, B, C) en zet vast zoals afgebeeld.

De ladesteunen moeten tussen de 3e en 4e sleuf worden geplaatst en naar buiten wijzen.

STAP 3:
Bevestig de 4 werkbladsteunen (F) aan de voor- en achterpoten (A, B, C) zoals afgebeeld.

De korte werkbladsteunen moeten tussen de 1e / 2e en 5e / 6e sleuf worden geplaatst.

HANDLEIDING

MONTAGE-INSTRUCTIES

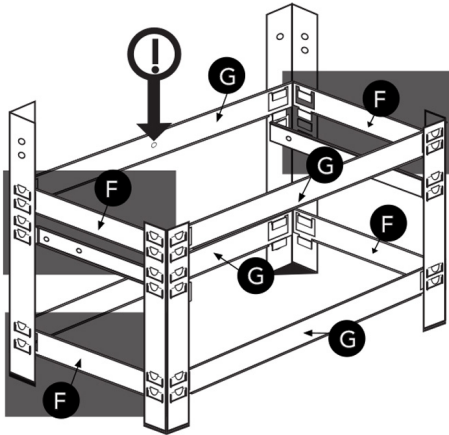

STAP 4:

Bevestig de 4 lange werkbladsteunen (G) aan de voor- en achterpoten (A, B, C) bij de 1e / 2e en 5e / 6e sleuf.

De lange werkbladsteun met het centrale gat moet tussen de 1e / 2e sleuf op de achterpoten (B, C) worden geplaatst.

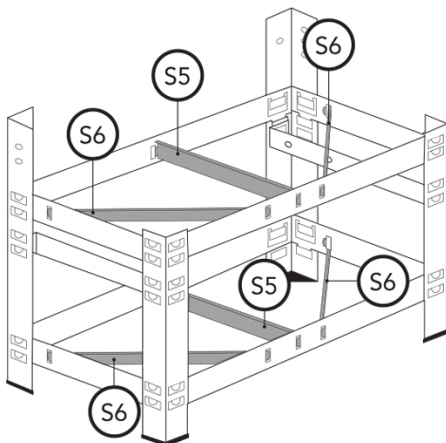

STAP 4.1:

Monteer de steunen (S5 & S6) op het frame.

STAP 5:

Buig de lipjes aan elk uiteinde van de steunbalken (S5) in een hoek van 90°. Zoek de sleuf aan de boven- en onderkant en schuif ze op hun plaats tussen de voorste en achterste zijbalken (G).

Buig de lipjes terug (zoals hieronder weergegeven) om te bevestigen.



Plaats de linker en rechter bovenste verticale steunen (H, I) in de zijkanten van de achterpoten (B, C).

Zet vast met 4 korte schroeven (V).

Draai vast met een geschikte sleutel. Zet de Steunbalken (S5) vast met (W).

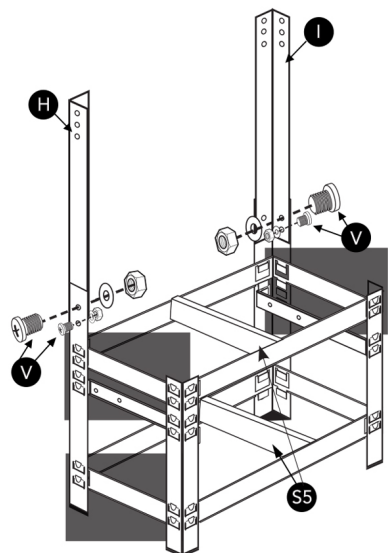

HANDLEIDING

MONTAGE-INSTRUCTIES

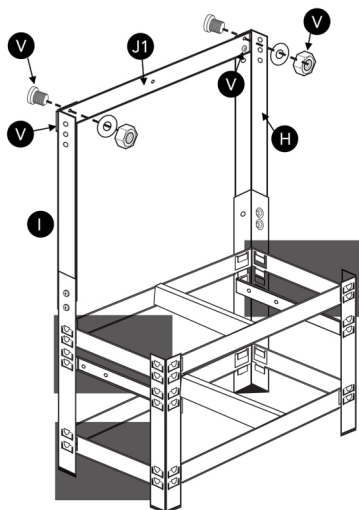

STAP 6:
Bevestig de rugsteun (J1) aan de bovenste 2 gaten van de verticale steunen (H, I). Zet vast met 4 korte schroeven (V). Draai vast.

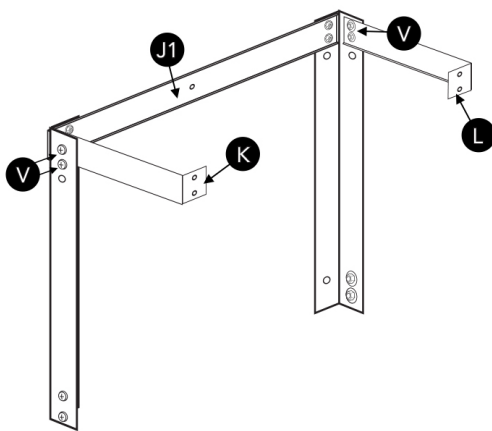

STAP 7:
Bevestig de langste rand van de korte bovenste plankdragers (K, L) aan de bovenste 2 gaten van de verticale steunen (H, I) met 4 korte schroeven (V) zoals afgebeeld. Draai vast.

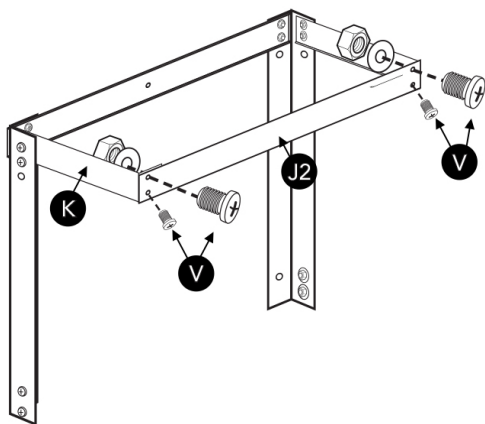

STAP 8:
Bevestig de voorste steun (J2) aan de voorkant van de korte bovenste plankdragers (K, L) met 4 korte schroeven (V) zoals afgebeeld. Draai vast.

HANDLEIDING

MONTAGE-INSTRUCTIES

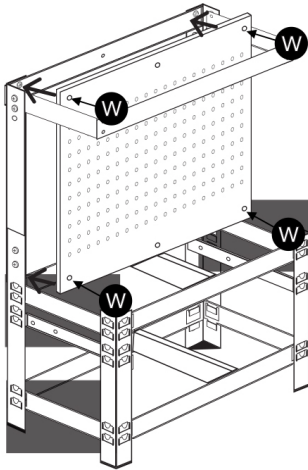

STAP 9:
Bevestig het ophangbord (Q) met 4 lange schroeven (W). Draai vast.

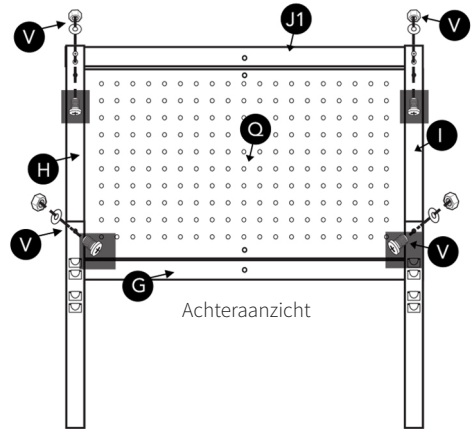

STAP 10:
Steek vanaf de achterkant 4 korte schroeven (V) in de lege gaten in de verticale steunen (H, I). Draai vast.

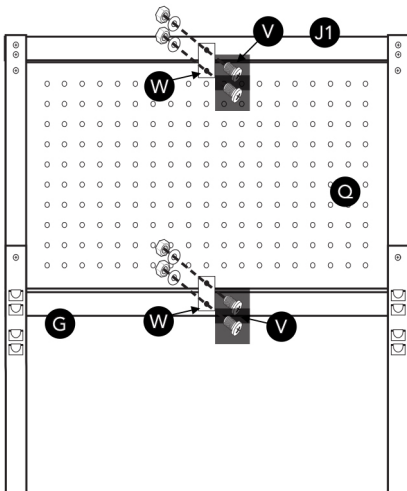

STAP 11:
Bevestig de Ophangbord-steunen (Y) met 2 korte schroeven (V) aan de achterkant van de constructie door de lege gaten op de lange steunen (G, J1).

Steek 2 Lange Schroeven (W) in de lege gaten op de Ophangbord-steunen (Y) en in het Ophangbord (Q). Draai alles stevig vast.

HANDLEIDING

MONTAGE-INSTRUCTIES

STAP 12:

Bevestig de 2 ladegreepjes (S1) aan het ladefront (M) door 8 kleine moeren / bouten (X) van buiten naar binnen in de richels te steken. Draai vast.

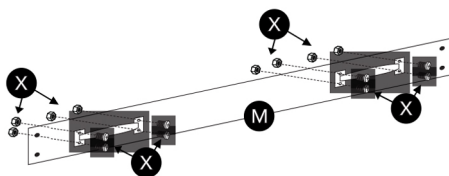

STAP 13:

Bevestig de Korte Ladezijden (O) aan het Ladefront (M) met 4 korte schroeven (V). Draai vast.

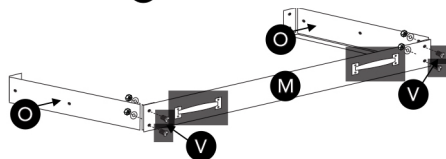

STAP 14:

Laat de Ladebodem (P) in de Ladeconstructie zakken om op de binnenste richels te rusten. Bevestig de Lade Achterkant (N) aan de montage met 4 korte schroeven (V).

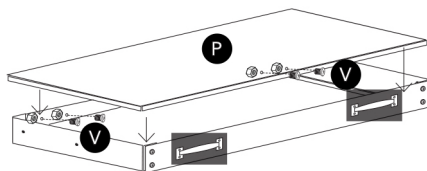

STAP 15:

Bevestig de 2 ladegeleiders (U) aan de korte ladekanten (O) met 4 kleine moeren / bouten (X) door de beschikbare gaten zoals afgebeeld. Draai vast.

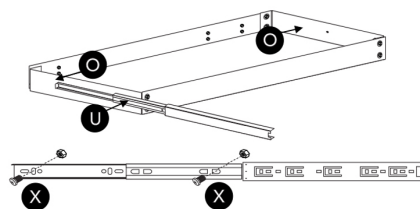

STAP 16:

Houd de lade voor werkbank, trek de ladegeleiders (U) uit en lijn ze uit met de bevestigingsgaten in de ladesteunen (D, E). Steek 4 kleine bouten (X) door de lopers en in de steunen. Draai vast.

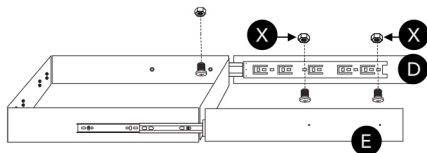

Plaats de ladesteun (S4) in het midden van de lade en zet hem vast met (W).

HANDLEIDING

MONTAGE-INSTRUCTIES

STAP 17:

Monteer de bovenste plank (T), het werkblad (S) en de onderste plank (R) door ze voorzichtig naar de juiste niveaus op de werkbank te laten zakken, zoals afgebeeld.

AANVULLEND: Steek pinnen (S2) in het ophangbord (Q) om gereedschap op te hangen voor het gemak.

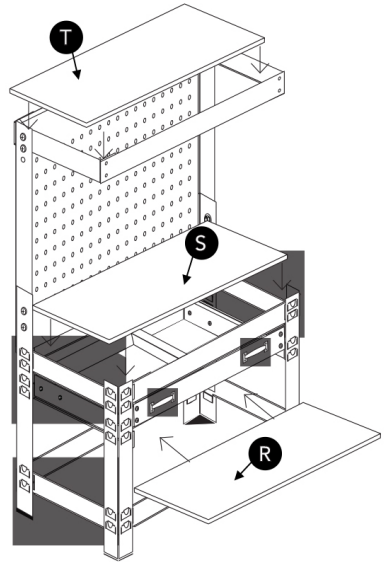

PROBLEMEN OPLOSSEN

RESOLUTIEGIDS

WAT MOET IK DOEN ALS ER ONDERDELEN ONTBREKEN UIT MIJN BESTELLING?

Als er een onderdeel ontbreekt in uw bestelling, neem dan binnen 7 dagen na ontvangst contact op met ons vriendelijke en behulpzame klantenserviceteam.

VOOR ALLE ANDERE VRAGEN, NEEM CONTACT OP MET ONS KLANTENSERVICETEAM.



Monster Group (UK) is one of the UK's fastest growing online retailers. We supply a diverse range of products which offer exceptional value for money. We strive to provide the best possible customer experience with free UK delivery across all our products and a Monster Guarantee for 100% satisfaction.

For information regarding this device or other products from our Monster divisions please contact Sales.

SALES

TEL: 01347 878 888

EMAIL: hello@monstershop.co.uk

For queries about this device, warranty, returns or reporting faults please contact Support.

SUPPORT

TEL: 01347 878 887

EMAIL: help@monstershop.co.uk

Pour plus d'informations concernant cet appareil ou d'autres produits de nos divisions de Monster veuillez utiliser les détails suivants ci-dessous.

DÉPARTEMENT COMMERCIAL

TEL: 01347 878 888

EMAIL: bonjour@monstershop.eu

Pour les interrogations concernant cet appareil, la garantie, les retours ou les défauts de déclaration veuillez utiliser les détails suivants ci-dessous.

DÉPARTEMENT DE SOUTIEN

TEL: 01347 878 887

EMAIL: help@monstershop.co.uk

Para información sobre este dispositivo u otros productos de nuestras divisiones de Monster por favor use los siguientes detalles.

DEPARTAMENTO DE VENTAS

TEL: 01347 878 888

EMAIL: hola@monstershop.eu

Para consultas sobre este dispositivo, la garantía, devoluciones o denuncias de fallos por favor use los siguientes detalles.

DEPARTAMENTO DE SOPORTE

TEL: 01347 878 887

EMAIL: help@monstershop.co.uk

Für Informationen bezüglich dieses Geräts oder anderer produkte aus unserer Monster-Abteilung, benutzen sie die folgenden unten aufgeführten angaben.

VERKAUFABTEILUNG

TEL: 01347 878 888

EMAIL: hallo@monstershop.eu

Für fragen über dieses gerät, die garantie, rückgaben oder bei störungen, benutzen sie die folgenden unten aufgeführten angaben.

SUPPORT-ABTEILUNG

TEL: 01347 878 887

EMAIL: help@monstershop.co.uk

Per informazioni riguardanti questo dispositivo o altri prodotti dalle categorie Monster utilizzare i dettagli sotto riportati.

DIPARTIMENTO VENDITE

TEL: 01347 878 888

EMAIL: ciao@monstershop.eu

Per domande riguardo dispositivo, garanzia, reso o per riferire di guasti, utilizzare i dettagli sotto riportati.

DIPARTIMENTO SUPPORTO

TEL: 01347 878 887

EMAIL: help@monstershop.co.uk

Monster House, Alan Farnaby Way,
Sheriff Hutton Industrial Estate,
Sheriff Hutton, York, YO60 6PG
www.monstershop.co.uk



 Try **Monster**. Buy **Monster**. Be **Monster**. 

