

# GALVANISED FEED STORE LARGE 2 COMPARTMENT

26926

INSTRUCTION MANUAL

[www.monstershop.co.uk](http://www.monstershop.co.uk)



# SPECIFICATION

## PRODUCT DESCRIPTION

The Galvanised Feed Store is a storage solution suited for stables, small holdings, farms, and gardens.

This Feed Store is made from heavy duty steel and is riveted and bolted together, making it easy to assemble and water resistant. The galvanised finish makes this store durable and it will maintain its excellent condition for even longer.

The Galvanised Feed Store comes in 3 styles: single compartment, dual compartment, or triple compartment.

## SAFETY ADVICE

### SAFE WORKING PRACTICE

**Please read through the Safe Working Practice to ensure prevention of injury or damage to the device.**

- Do not use this product for anything other than its intended purposes.
- Always keep the weight evenly distributed to avoid damage to the store.
- Do not sit/stand on or inside the store.
- When closing store be careful not to trap digits.
- Do not exceed volume or weight capacity of store.
- Wear gloves when assembling this store to protect your hands. Be careful when using the rivet gun to assemble the store.
- Ensure that each panel is properly secured into place before continuing with the assembly process.
- Ensure Store is built on stable, level ground.
- Do not use corrosive cleaning equipment when cleaning your feed store. Including Bleach and chlorine-based cleaners.







Monster Group UK Limited's liability will be limited to the commercial value of the product only.

# SPECIFICATION

## PRODUCT SPECIFICS

MATERIAL:	Galvanised steel
DIMENSIONS:	91 cm(H) x 111(W) x 65(D) cm
VOLUME CAPACITY:	600L
WEIGHT CAPACITY:	175KG

## ITEM CONTENTS

H	x 61	
I	x 2	
J	x 4	
K	x 2	
L	x 2	
M	x 2	

- A. 1x Base Panel
- B. 1x Front Panel
- C. 1x Rear Panel
- D. 1x Side Panel (Right)
- E. 1x Side Panel (Left)
- F. 1x Divider Panel
- G. 1x Lid
- H. 1x Lid Handle

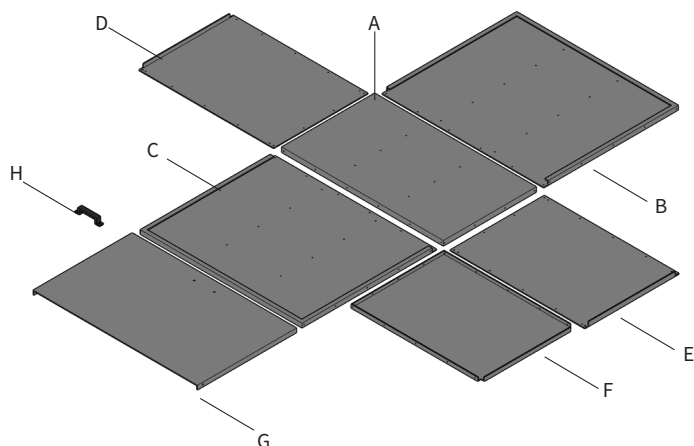

STEP BY STEP INSTRUCTIONS ON PAGE 14-17

# SPÉCIFICATIONS

## DESCRIPTION DU PRODUIT

Le conteneur d'aliment pour animaux est une solution de stockage adaptée aux écuries, aux petites exploitations, aux fermes et aux jardins.

Ce conteneur d'aliments pour animaux est fabriqué en acier résistant et est riveté et boulonné ensemble, ce qui le rend facile à assembler et résistant à l'eau. La finition galvanisée rend ce conteneur durable et il conservera son excellent état encore plus longtemps.

Le conteneur d'aliments pour animaux galvanisé existe en trois modèles : à compartiment unique, à double compartiment ou à triple compartiment.

## CONSEILS DE SÉCURITÉ

### PRATIQUES DE TRAVAIL SÉCURITAIRE

**Veillez lire le document intitulé Pratiques de travail sécuritaires afin de prévenir les blessures ou les dommages à l'appareil.**

- N'utilisez pas ce produit à d'autres fins que celles pour lesquelles il a été conçu.
- Veillez toujours à ce que le poids soit réparti uniformément pour éviter d'endommager le magasin.
- Ne pas s'asseoir/se tenir debout sur ou dans le magasin.
- Lors de la fermeture du magasin, veillez à ne pas piéger les chiffres.
- Ne pas dépasser le volume ou la capacité de poids du magasin.
- Portez des gants lors de l'assemblage de ce magasin pour protéger vos mains. Faites attention lorsque vous utilisez le pistolet à rivets pour assembler le magasin.
- Assurez-vous que chaque panneau est correctement fixé en place avant de poursuivre le processus d'assemblage.
- Assurez-vous que le magasin est construit sur un sol stable et plat.
- N'utilisez pas de matériel de nettoyage corrosif lorsque vous nettoyez votre magasin d'aliments pour animaux. Y compris l'eau de Javel et les nettoyeurs à base de chlore.







La responsabilité de Monster Group UK Limited sera limitée à la valeur commerciale du produit.

# SPÉCIFICATIONS

## SPÉCIFICATIONS DU PRODUIT

MATÉRIEL :	Acier galvanisé
DIMENSIONS :	91 cm(H) x 111(L) x 65(P) cm
CAPACITÉ DE VOLUME :	600L
CAPACITÉ DE POIDS :	175Kg

## CONTENU DES ARTICLES

H	x 61	
I	x 2	
J	x 4	
K	x 2	
L	x 2	
M	x 2	

- A. 1x Panneau de base
- B. 1x Panneau frontal
- C. 1x Panneau arrière
- D. 1x Panneau latéral (droite)
- E. 1x Panneau latéral (gauche)
- F. 1x Panneau diviseur
- G. 1x Couvercle
- H. 1x Poignée du couvercle

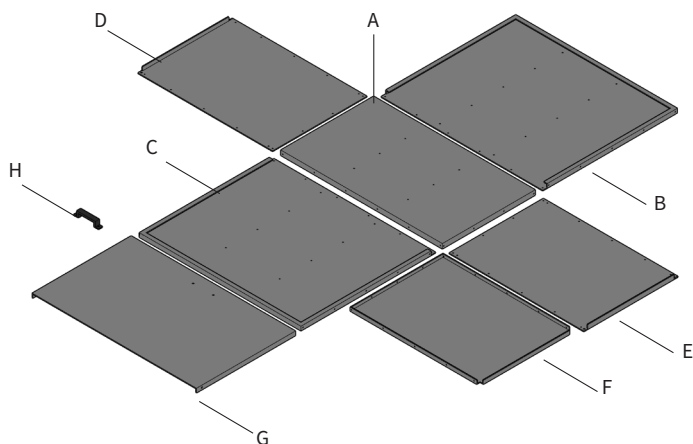

INSTRUCTIONS ÉTAPE PAR ÉTAPE À LA PAGE 14-17



# SPEZIFIKATIONEN

## PRODUKTBESCHREIBUNG

Die verzinkte Futteraufbewahrung ist eine Lagerlösung, die sich für Ställe, kleine Betriebe, Bauernhöfe und Gärten eignet.

Dieses Futterlager wurde aus hochbelastbarem Stahl gefertigt und ist vernietet und verschraubt, wodurch es leicht zu montieren und wetterbeständig ist.

Die verzinkte Oberfläche macht dieses Lager langlebig und behält dadurch noch länger seinen ausgezeichneten Zustand.

Das Futterlager ist in 3 verschiedenen Ausführungen erhältlich: mit einem, zwei oder drei Fächern.

# SICHERHEITSHINWEIS



## SICHERES ARBEITEN

**Bitte lesen Sie die Sicherheitshinweise durch, um Verletzungen oder Schäden am Gerät zu vermeiden.**

- Verwenden Sie dieses Produkt NUR für die vorgesehenen Zwecke.
- Halten Sie das Gewicht immer gleichmäßig verteilt, um Schäden am Gerät zu vermeiden
- Sitzen oder stehen Sie nicht auf oder in dem Lager.
- Achten Sie beim Schließen des Lagers auf Ihre Finger.
- Überschreiten Sie nicht das Volumen oder die Gewichtskapazität der Aufbewahrung.
- Tragen Sie beim Zusammenbauen Handschuhe, um Ihre Hände zu schützen. Seien Sie vorsichtig, wenn Sie die Nietpistole beim Zusammenbau verwenden.
- Vergewissern Sie sich, dass jede Platte ordnungsgemäß befestigt ist, bevor Sie mit dem Zusammenbau fortfahren. Stellen Sie sicher, dass das Futterlager auf einem stabilen und ebenen Untergrund steht.
- Verwenden Sie beim Reinigen Ihrer Futteraufbewahrung keine ätzende Reinigungsmittel. Einschließlich Bleichmittel und Reinigungsmittel auf Chlorbasis.







Die Haftung von Monster Group UK Limited ist auf den Handelswert des Produkts beschränkt.

# SPEZIFIKATIONEN

## PRODUCTMERKMALE

MATERIAL:	Verzinkter Stahl
MAßE:	91 cm (H) x 111 cm (L) x 65 cm (B)
FASSUNGSVERMÖGEN:	600L
GEWICHTSKAPAZITÄT:	175Kg

## PACKUNGSGEHALT

H	x 61	
I	x 2	
J	x 4	
K	x 2	
L	x 2	
M	x 2	

- A. 1x Grundplatte
- B. 1x Vorderwand
- C. 1x Rückwand
- D. 1x Seitenwand (Rechts)
- E. 1x Seitenwand (Links)
- F. 1x Trennwand
- G. 1x Deckel
- H. 1x Griff für Deckel

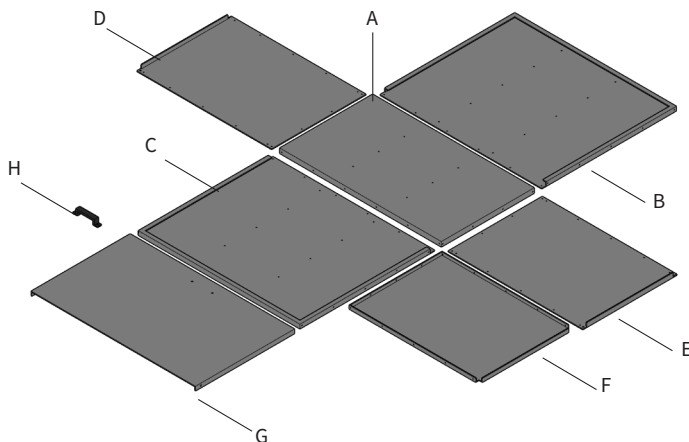

SCHRITT-FÜR-SCHRITT-ANLEITUNGEN AUF SEITE 14-17



# ESPECIFICACIONES

## DESCRIPCIÓN DEL PRODUCTO

El almacén de piensos galvanizados es una solución de almacenamiento adecuada para establos, pequeñas explotaciones, granjas y jardines.

Este almacén de piensos está hecho de acero de alta resistencia y está remachado y atornillado, lo que lo hace fácil de montar y resistente al agua. El acabado galvanizado hace que este almacén sea duradero y mantendrá su excelente condición por más tiempo.

El almacén de alimentos galvanizados viene en 3 estilos: de un solo compartimiento, de doble compartimiento o de triple compartimiento.

## CONSEJOS DE SEGURIDAD

### ! PRÁCTICAS DE TRABAJO SEGURAS

Por favor, lea la Práctica de Trabajo Seguro para asegurar la prevención de lesiones o daños en el dispositivo.

- No utilice este producto para otros fines que no sean los previstos.
- Mantenga siempre el peso distribuido uniformemente para evitar daños en la tienda.
- No te sientes o te pares sobre o dentro de la tienda.
- Cuando cierre la tienda tenga cuidado de no atrapar los dígitos.
- No exceda la capacidad de volumen o peso de la tienda.
- Use guantes cuando monte la tienda para protegerse las manos. Tenga cuidado al usar la pistola de remaches para montar la tienda.
- Asegúrese de que cada panel esté bien sujeto en su lugar antes de continuar con el proceso de montaje.
- Asegúrese de que la tienda se construye en un terreno estable y nivelado.
- No utilice un equipo de limpieza corrosivo cuando limpie su almacén de alimentación. Incluyendo blanqueador y limpiadores a base de cloro.

La responsabilidad de Monster Group UK Limited estará limitada únicamente al valor comercial del producto.









# ESPECIFICACIONES

## ESPECIFICACIONES DEL PRODUCTO

MATERIAL:	Acero galvanizado
DIMENSIONES:	91 cm(A) x 111(A) x 65(D) cm
CAPACIDAD DE VOLUMEN:	600L
CAPACIDAD DE PESO:	175Kg

## CONTENIDO DEL ARTÍCULO

H	x 61	
I	x 2	
J	x 4	
K	x 2	
L	x 2	
M	x 2	

- A. 1x Panel base
- B. 1x Panel frontal
- C. 1x Panel trasero
- D. 1x Panel lateral (derecha)
- E. 1x Panel lateral (Izquierda)
- F. 1x Panel divisor
- G. 1x Tapa
- H. 1x Mango de la tapa

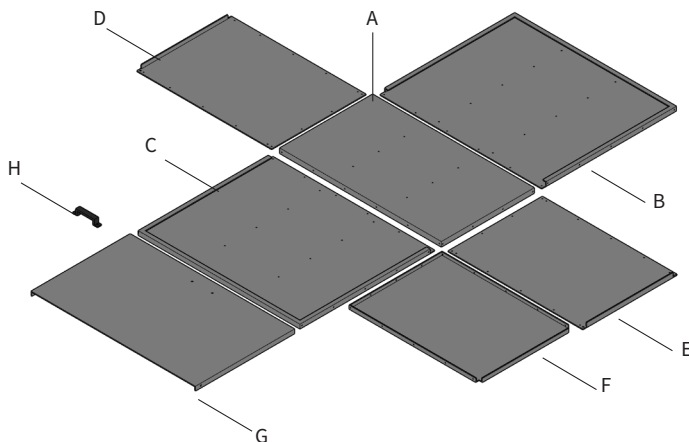

INSTRUCCIONES PASO A PASO EN LA PÁGINA 14-17

# SPECIFICHE

## DESCRIZIONE DEL PRODOTTO

La mangiatoia in acciaio galvanizzato è una soluzione perfetta per stalle, fattorie, piccole proprietà e giardini.

Costruita in acciaio resistente con rivetti e bulloni, facile da assemblare e resistente all'acqua. La finitura galvanizzata la rende durevole e resistente per un uso prolungato.

La mangiatoia arriva in 3 modelli: compartimento singolo, doppio o triplo.

## AVVISO DI SICUREZZA

### PROCEDURA D'USO IN SICUREZZA

**Prego leggere l'avviso di sicurezza per prevenire lesioni all'utente o danni al dispositivo.**

- Non usare il prodotto per scopi diversi da quelli previsti.
- Distribuire il peso uniformemente per non danneggiare la struttura.
- Non salire o sedersi nel o sul prodotto.
- Nel chiudere il coperchio fare attenzione a non schiacciarsi le dita.
- Non eccedere capacità o volume del prodotto.
- Indossare guanti durante l'assemblaggio del prodotto per protezione delle mani. Fare attenzione nell'usare la rivettatrice.
- Assicurarsi che ogni pannello sia assicurato in posizione prima di procedere con il prossimo.
- Assicurarsi che la struttura sia assemblata su terreno stabile e livellato.
- Non usare prodotti corrosivi per pulire la struttura, inclusi candeggina e prodotti a base di cloro.







La responsabilità di Monster Group UK Limited sarà limitata al solo valore commerciale del prodotto.

# SPECIFICHE

## SPECIFICHE PRODOTTO

<b>MATERIALE:</b>	Acciaio Galvanizzato
<b>DIMENSIONI:</b>	91 cm(Altezza) x 111(Larghezza) x 65(Profondità) cm
<b>VOLUME:</b>	600L
<b>CAPACITA':</b>	75Kg

## CONTENUTO SCATOLA

H	x 61	
I	x 2	
J	x 4	
K	x 2	
L	x 2	
M	x 2	

- A. 1x Pannello di base
- B. 1x Pannello frontale
- C. 1x Pannello posteriore
- D. 1x Pannello laterale (Destro)
- E. 1x Pannello laterale (Sinistro)
- F. 1x Pannello divisore
- G. 1x Coperchio
- H. 1x Maniglia coperchio

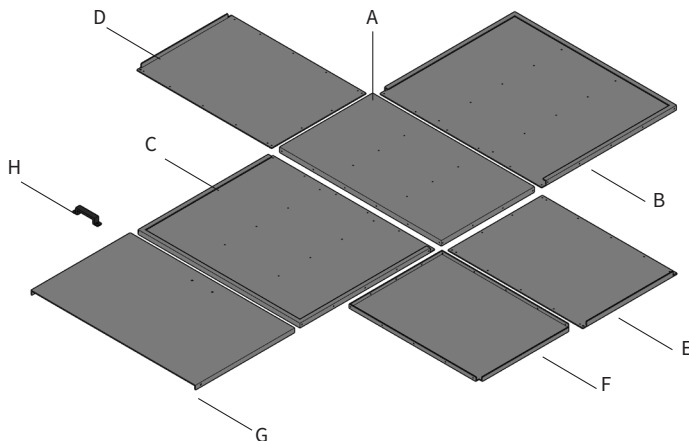

ISTRUZIONI PASSO A PASSO A PAGINA 14-17

# SPECIFICATIE

## PRODUCT BESCHRIJVING

De gegalvaniseerde voeropslag is een opslagoplossing die geschikt is voor stallen, kleine bedrijven, boederijen en tuinen. Deze voeropslag is gemaakt van zwaar staal en is aan elkaar gekoppeld en vastgeschroefd, waardoor hij gemakkelijk te monteren is en bestand is tegen water.

De gegalvaniseerde afwerking maakt deze opslagplaats duurzaam en het zal zijn uitstekende conditie nog langer behouden.

De gegalvaniseerde voeropslag is verkrijgbaar in 3 stijlen: een enkel compartiment, een dubbel compartiment of zelfs een drievoudig compartiment.

# VEILIGHEIDSOVEREENKOMST

## VEILIG WERKEN

**Lees dit onderdeel van de handleiding goed door om letsel of schade aan het apparaat of bij uzelf te voorkomen.**

- Gebruik dit product niet voor andere doeleinden dan waarvoor het bested is.
- Zorg ervoor dat het gewicht altijd gelijkmatig verdeeld is om schade aan het product te voorkomen.
- Ga niet op het product zitten en/of staan.
- Let er bij het sluiten van de deksel op dat uw vingers niet klemt.
- Do not exceed volume or weight capacity of store.
- Overschrijd de gewichts en volume capaciteit van het product niet.
- Draag handschoenen bij de montage van dit product om uw handen te beschermen. Wees extra voorzichtig bij het gebruik van het klinknagelpistool die u gebruikt bij het in elkaar zetten van de unit.
- Zorg ervoor dat elk panel goed op zijn plaats zit voordat u verder gaat met de montage.
- Zorg ervoor dat het product op een stabiele, vlakke ondergrond geplaatst wordt.
- Gebruik alstublieft geen bijtende reinigingsapparatuur bij het reinigen van uw voeropslag. Unclusief bleekmiddel en chloorhoudende reinigingsmiddelen.







De aansprakelijkheid van Monster Group UK Limited is beperkt tot de commerciële waarde van het product.

# SPECIFICATIE

## PRODUCT SPECIFICATIES

MATERIAAL:	Verzinkt/Gegalvaniseerd staal
VAFMETINGEN:	91 cm(H) x 111(W) x 65(D) cm
INHOUDSCAPICITEIT:	600L
GEWICHTSCAPICITEIT:	175Kg

## ITEM BEVAT:

H	x 61	
I	x 2	
J	x 4	
K	x 2	
L	x 2	
M	x 2	

- A. 1x Basispaneel
- B. 1x Paneel voorkant
- C. 1x Paneel achterkant
- D. 1x Zijpaneel (Rechts)
- E. 1x Zijpaneel (Links)
- F. 1x Verdelingspaneel
- G. 1x Deksel
- H. 1x Dekselgreep

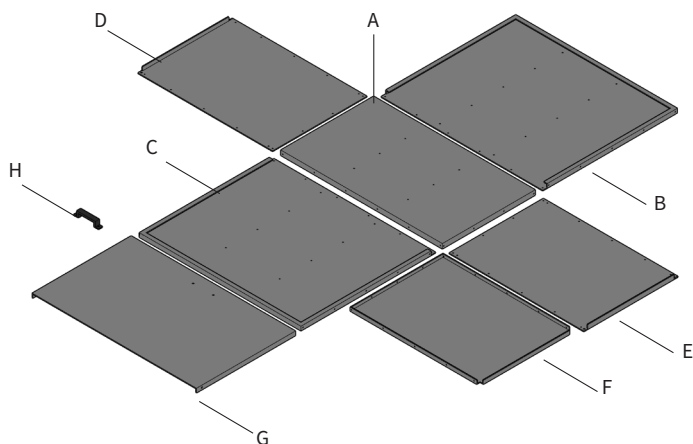

STAP VOOR STAP INSTRUCTIES OP PAGINA 14-17

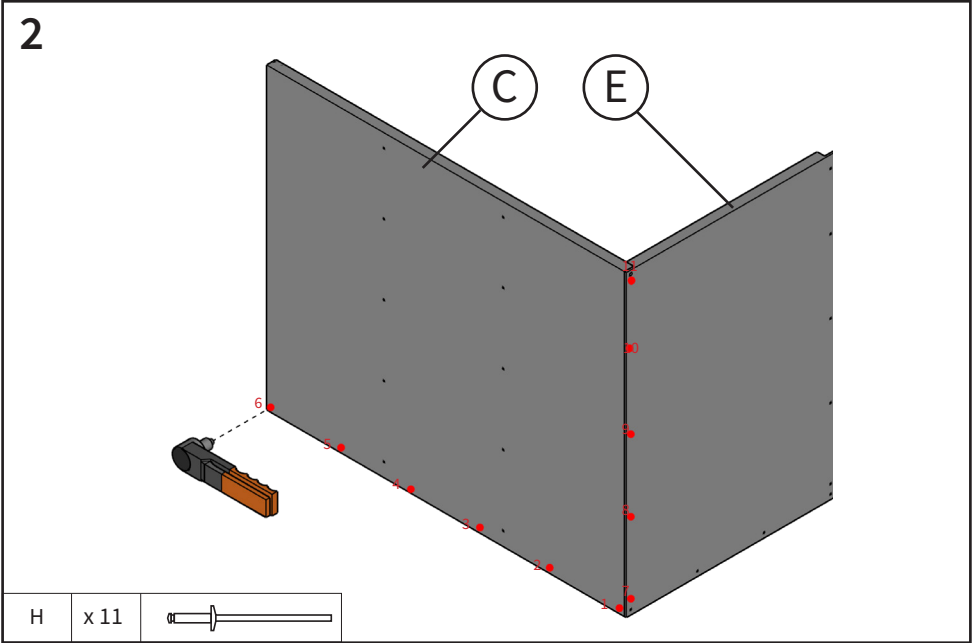
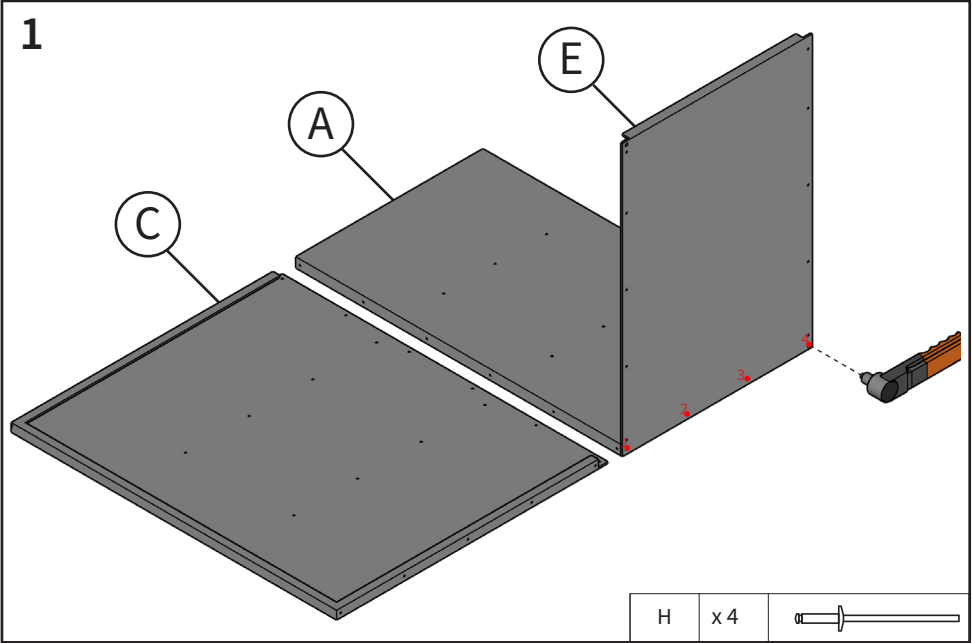

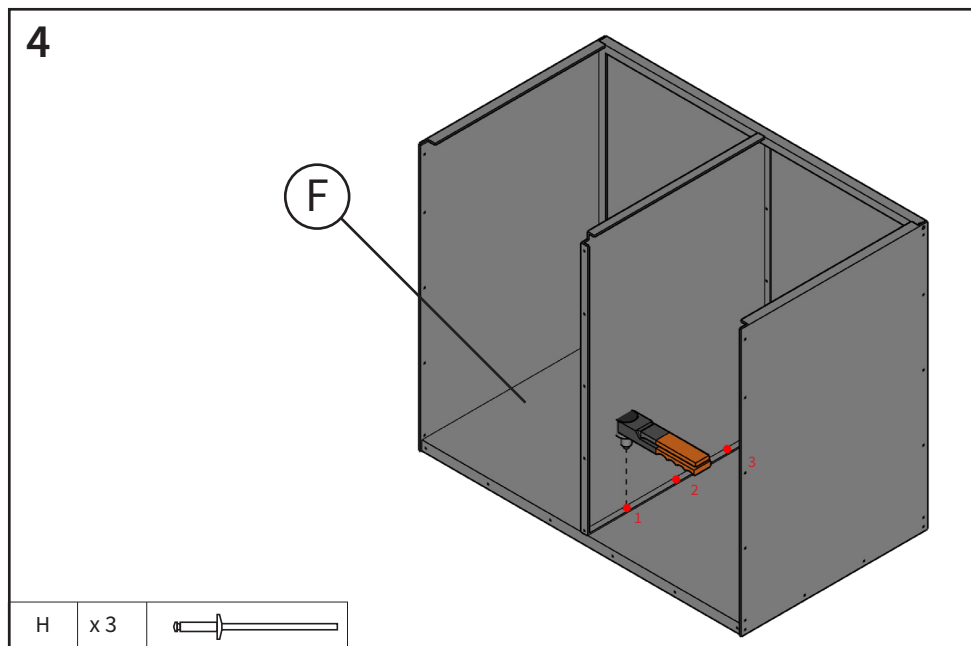
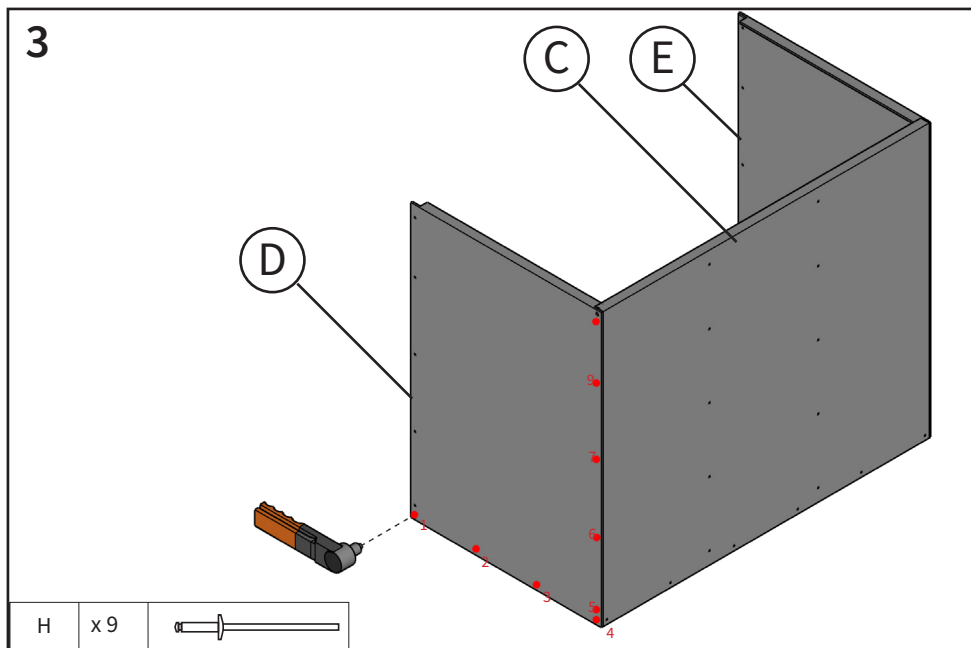

5

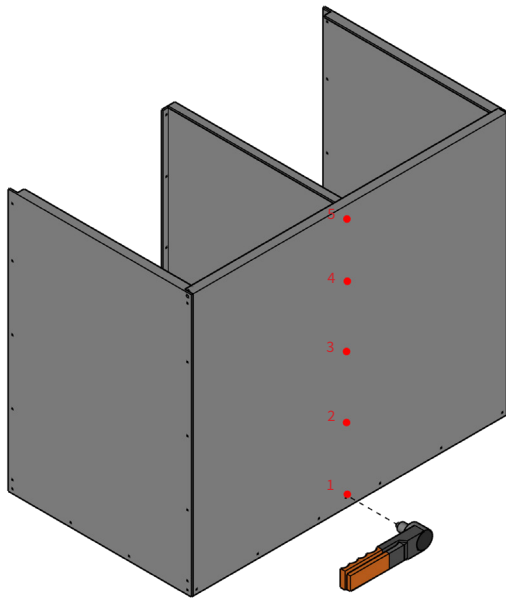

H

x 5

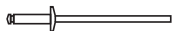

6

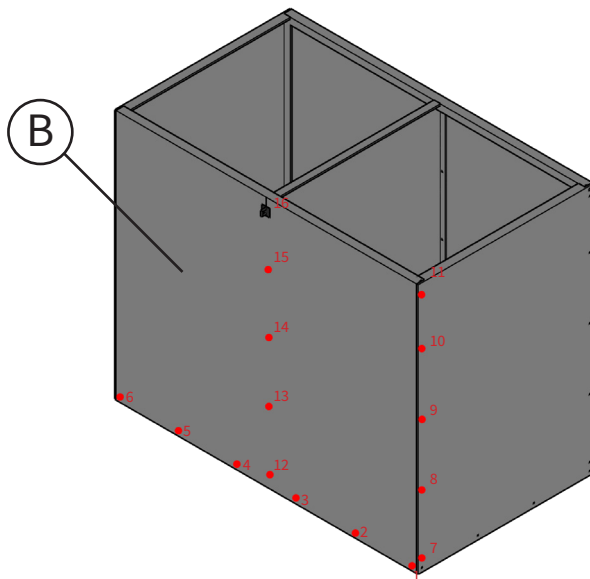

H



x 16





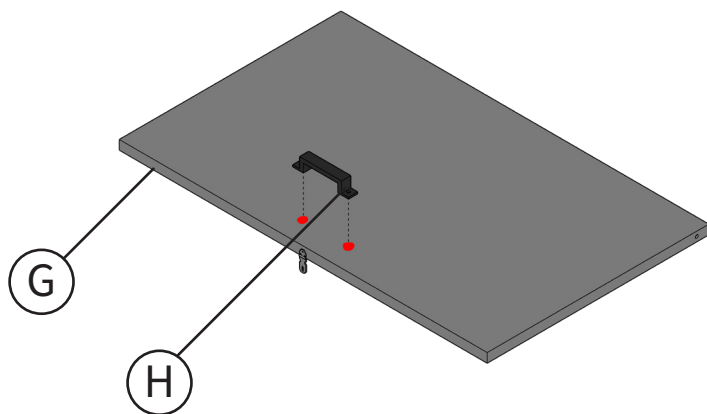



7

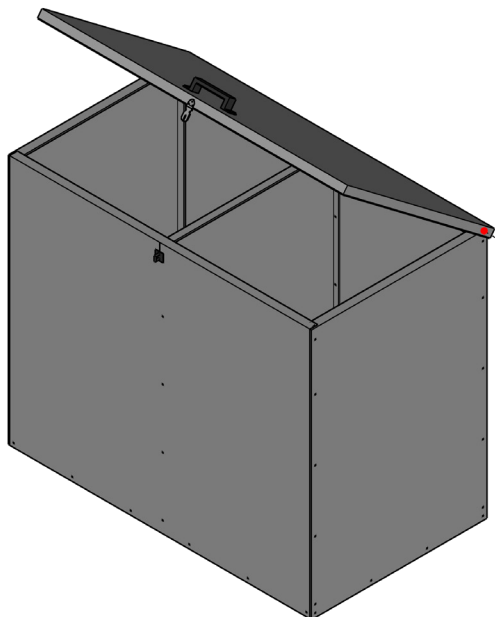

L	x2	
M	x2	

8



I	x2	
J	x4	
K	x2	



Monster Group (UK) is one of the UK's fastest growing online retailers. We supply a diverse range of products which offer exceptional value for money. We strive to provide the best possible customer experience with free UK delivery across all our products and a Monster Guarantee for 100% satisfaction.

For information regarding this device or other products from our Monster divisions please contact Sales.

### SALES

TEL: 01347 878 888

EMAIL: hello@monstershop.co.uk

For queries about this device, warranty, returns or reporting faults please contact Support.

### SUPPORT

TEL: 01347 878 887

EMAIL: help@monstershop.co.uk

Pour plus d'informations concernant cet appareil ou d'autres produits de nos divisions de Monster veuillez utiliser les détails suivants ci-dessous.

### DÉPARTEMENT COMMERCIAL

TEL: 01347 878 888

EMAIL: bonjour@monstershop.eu

Pour les interrogations concernant cet appareil, la garantie, les retours ou les défauts de déclaration veuillez utiliser les détails suivants ci-dessous.

### DÉPARTEMENT DE SOUTIEN

TEL: 01347 878 887

EMAIL: help@monstershop.co.uk

Para información sobre este dispositivo u otros productos de nuestras divisiones de Monster por favor use los siguientes detalles.

### DEPARTAMENTO DE VENTAS

TEL: 01347 878 888

EMAIL: hola@monstershop.eu

Para consultas sobre este dispositivo, la garantía, devoluciones o denuncias de fallos por favor use los siguientes detalles.

### DEPARTAMENTO DE SOPORTE

TEL: 01347 878 887

EMAIL: help@monstershop.co.uk

Für Informationen bezüglich dieses Geräts oder anderer Produkte aus unserer Monster-Abteilung, benutzen sie die folgenden unten aufgeführten Angaben.

### VERKAUFABTEILUNG

TEL: 01347 878 888

EMAIL: hallo@monstershop.eu

Für Fragen über dieses Gerät, die Garantie, Rückgaben oder bei Störungen, benutzen sie die folgenden unten aufgeführten Angaben.

### SUPPORT-ABTEILUNG

TEL: 01347 878 887

EMAIL: help@monstershop.co.uk

Per informazioni riguardanti questo dispositivo o altri prodotti dalle categorie Monster utilizzare i dettagli sotto riportati.

### DIPARTIMENTO VENDITE

TEL: 01347 878 888

EMAIL: ciao@monstershop.eu

Per domande riguardo dispositivo, garanzia, reso o per riferire di guasti, utilizzare i dettagli sotto riportati.

### DIPARTIMENTO SUPPORTO

TEL: 01347 878 887

EMAIL: help@monstershop.co.uk

Monster House, Alan Farnaby Way,  
Sheriff Hutton Industrial Estate,  
Sheriff Hutton, York, YO60 6PG  
[www.monstershop.co.uk](http://www.monstershop.co.uk)



 Try **Monster**. Buy **Monster**. Be **Monster**. 

