



# Polytunnel 25mm 6m x 3m

27250

INSTRUCTION MANUAL

[www.monstershop.co.uk](http://www.monstershop.co.uk)

# SPECIFICATION

## PRODUCT DESCRIPTION







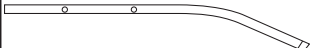

The Monster Polytunnel is a great solution for those short of space or needing extra space for planting a wide variety of seeds and plants.

## PRODUCT SPECIFICS

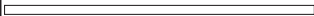

- Size: 6m (L) x 3m (W) x 2m (H)
- Galvanised steel pipe 25mm x 0.8mm
- 150gsm PE mesh cover
- 6 Windows + 2 Doors

## PARTS LIST

When first unpacking your polytunnel, check each part against this list to ensure that they are all present. If any are missing contact us before attempting to assemble.

Part No.	Description	Illustration	Quantity
1	Bottom Bar (front)		X2
2	Uprights		x4
3	Roof Bar (curved)		x18
4	Roof Bar (semi curved)		x6
5	Middle support Bar		x8
6	Bottom Bar (back)		x2
7	Diagonal Support Bar		x4
8	Support Bar (back)		x3
10	Support Bars		x18

## PARTS LIST

11	Under Bar A		x4
12	Under Bar B		x2
13	Cover		x1
14	Guy Rope & Peg		x 4
15	Nuts & Bolts		x58

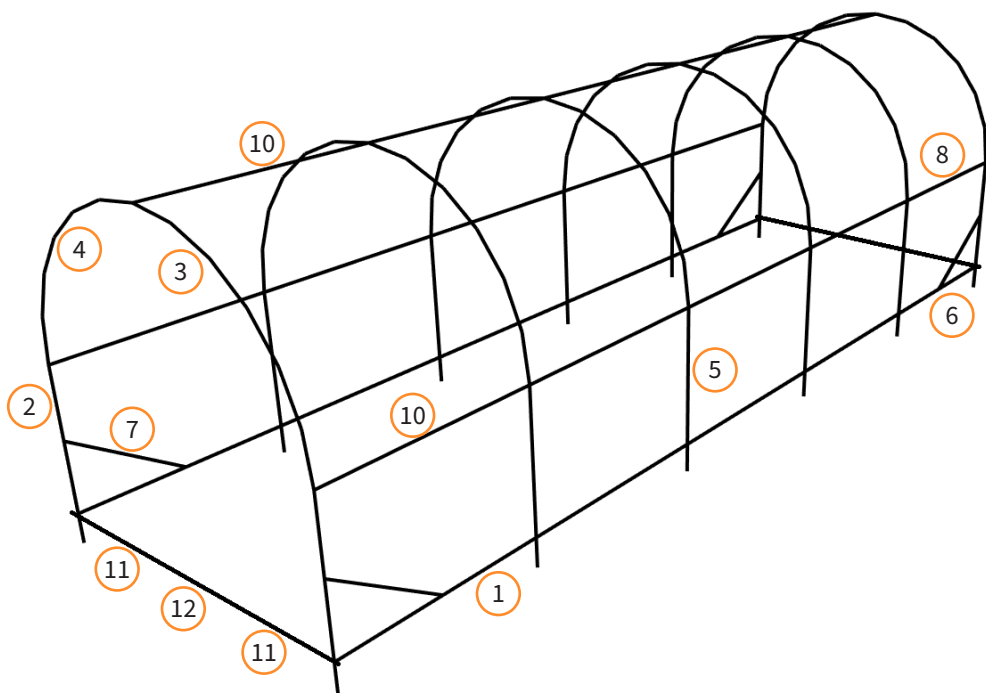

Monster Group UK Limited's liability will be limited to the commercial value of the product only.

# SAFETY ADVICE

## SAFE WORKING PRACTICE

Please read through the Safe Working Practice to ensure prevention of injury or damage to the polytunnel.

- Ensure you have read and fully understood the instruction manual and safety advice before assembling this product.
- Ensure that this polytunnel is handled and assembled according to these instructions.
- Do not attempt to assemble this polytunnel on a windy day.
- Ensure this polytunnel is assembled and erected on a flat surface.
- Ensure this product is assembled securely.
- Ensure this product is erected in a safe place.
- This product must be anchored to the ground.
- This produce must be dug into the ground as per these instructions.
- Do not use this product for anything other than its intended purposes.
- 2 people are required to assemble this polytunnel.
- Wear gloves during assembly of the polytunnel.

# USER GUIDE

## ASSEMBLY INSTRUCTIONS

1. Check you have each part that is needed to assemble the polytunnel.
2. First we will form the 6 arches for each arch you will need:
  - 2 x Uprights (2)
  - 3 x Roof Bar Curved (3)
  - 1 x Roof Bar Semi Curved (4)

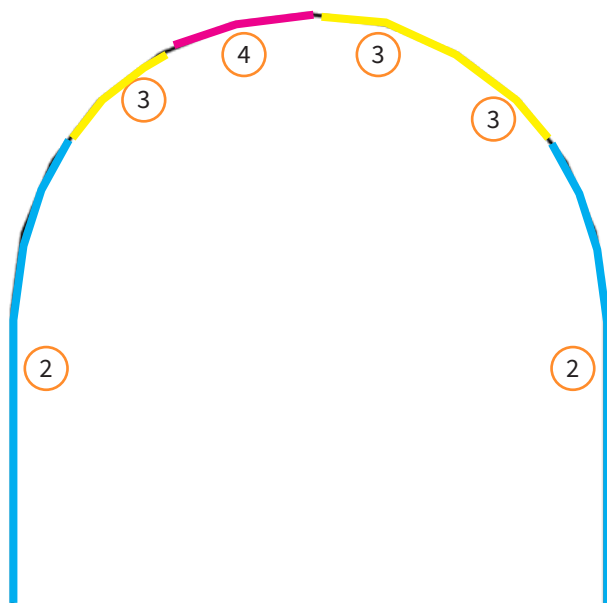

You will need to repeat this 6 times to make 6 complete sections like this.

First and last section will be done according to the diagram above.

For the middle sections, please use the **8 x Middle support Bars (5)** instead of the Uprights (2).

3. Next we are going to connect 2 of the completed sections together. For the purposes of these instructions this will be the front compound of the polytunnel.

You will need:

2 x Bottom Bar Front (**1**)

3 x Support Bar Front (**10**)

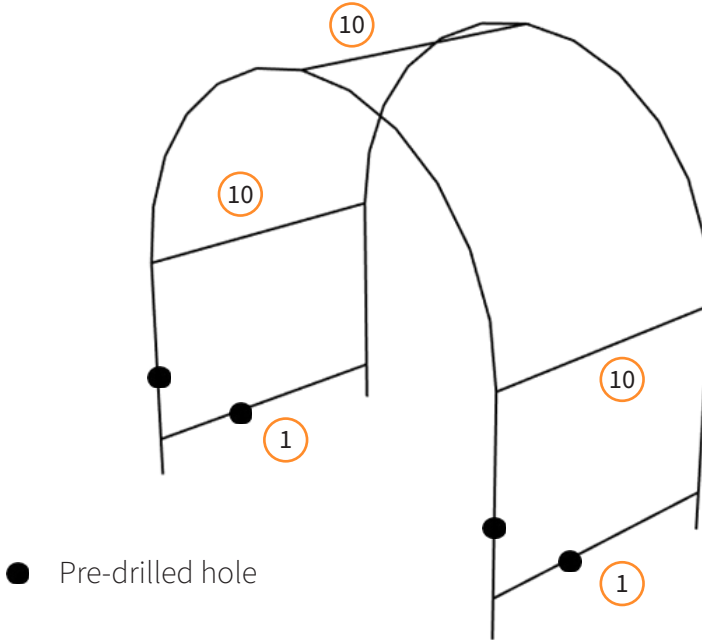

When attaching the Bottom Bars Front (**1**) and Support Bars Front (**10**) to the completed sections they need to be located on the inside of the polytunnel.

First attach 2 x Bottom Bar Front (**1**) to the front section; ensuring the predrilled holes, located around 1/3 of the way along each bar, are both located to closest to the front of the polytunnel.

Next attach the 3 x Support Bar Front (**10**) to the front of the polytunnel.

For the next step you will need someone to hold the Front of the polytunnel whilst you attach the other end of the Bottom Bars Front (**1**) and Support Bars Front (**10**) to the second completed section.

4. Our final step on the front section is to attach to 2 Diagonal Support Bars.  
You will need:  
2 x Diagonal Support Bar (7)

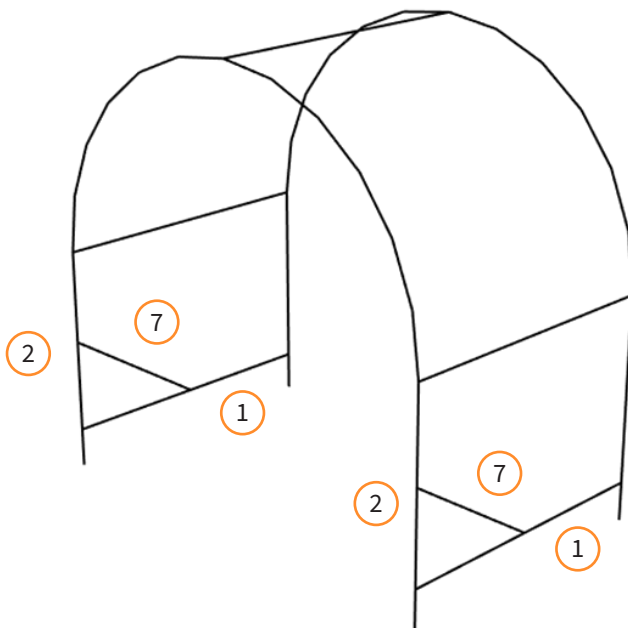

Attach one end of the Diagonal Support Bar (7) to the Upright (2) and then the other end into the predrilled hole on Bottom Bar Front (1).  
Repeat this step to attach both Diagonal Support Bars (7).

Now you have successfully completed one compound of the polytunnel.

5. Next we are going to connect the front compound to the other 3 sections (that we made in step 1).

You will need:

15 x Middle Support and Bottom Bar (10)

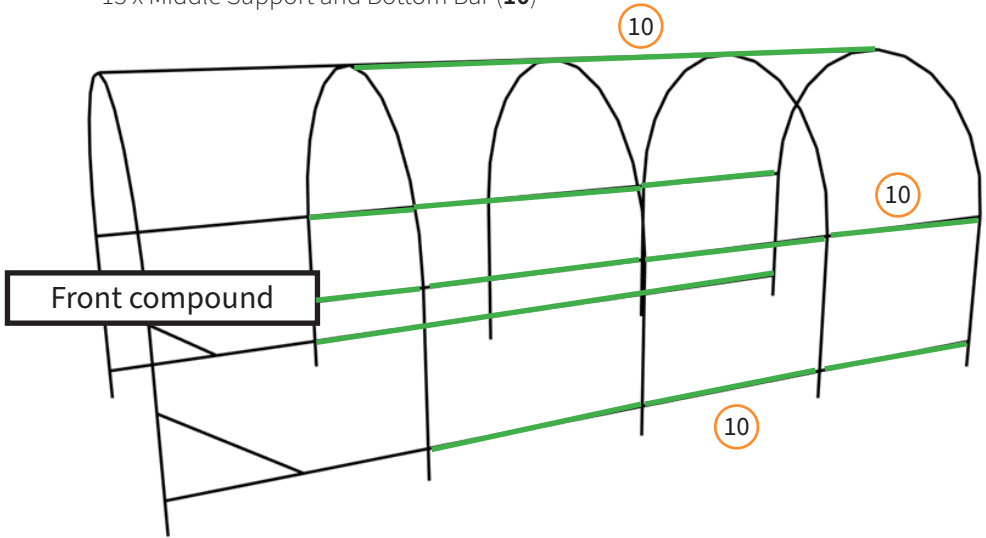

When attaching the Bottom Bars (10) and Support Bars (10) to the completed sections they need to be located on the inside of the polytunnel.

Attach each section according to instruction in step 3.



6. Next we are going to attach the back section (that we made in step 1) to the front and middle compounds to complete the polytunnel.

You will need:

2 x Bottom Bar Back (6)

3 x Support Bar Back (8)

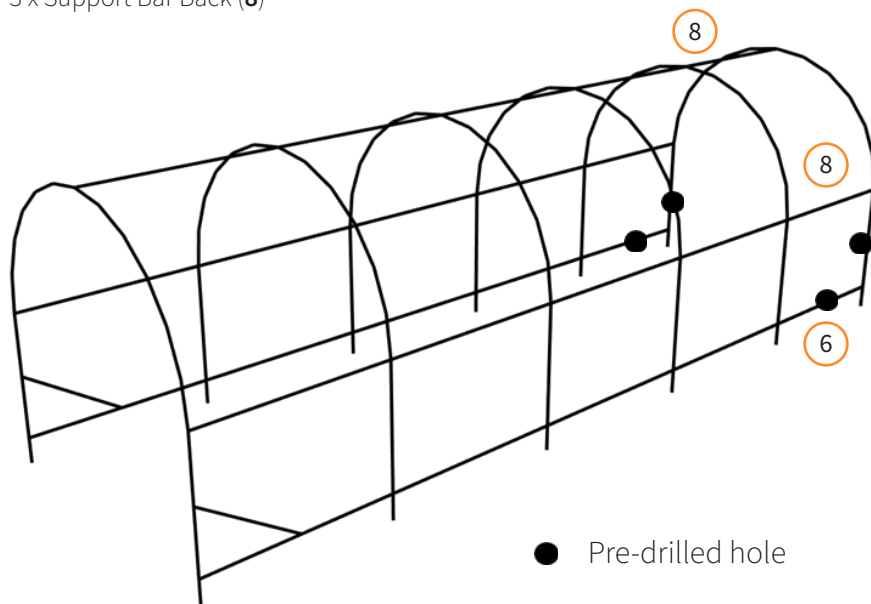

● Pre-drilled hole

When attaching the Bottom Bars Back (6) and Support Bars Back (8) to the completed sections they need to be located on the inside of the polytunnel.

First attach 2 x Bottom Bar Back (6) to the back section; ensuring the predrilled holes, located around 1/3 of the way along each bar, are both located to closest to the back of the polytunnel.

Next attach the 3 x Support Bar Back (8) to the back of the polytunnel.

7. Next we need to attach the final 2 Diagonal Support Bars, and the Front and Back underbars.

You will need:

2 x Diagonal Support Bar (7)

4 x Under Bar A (11)

2 x Under Bar B (12)

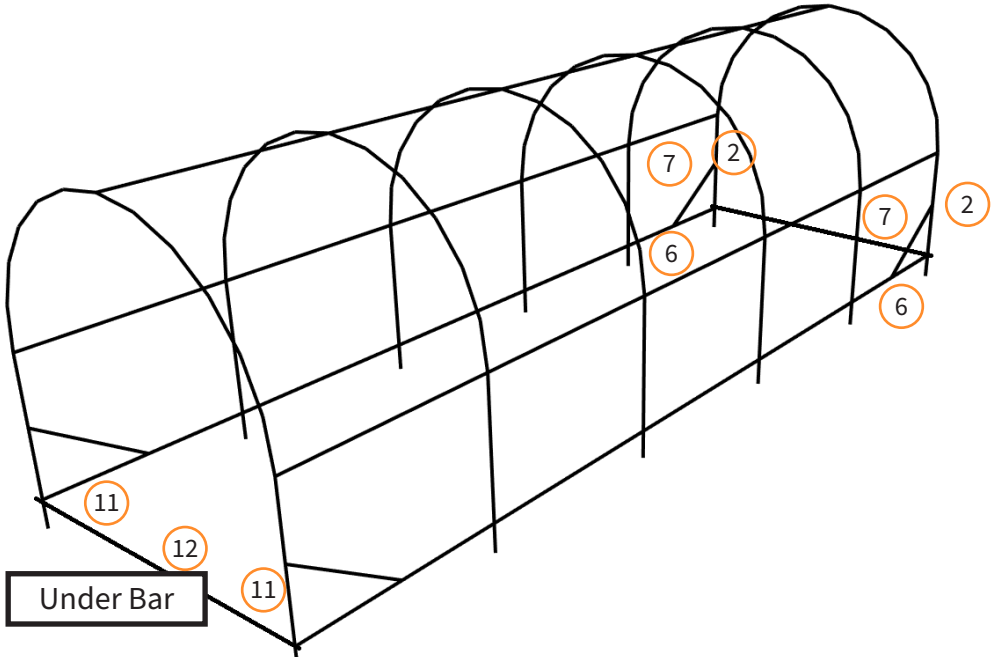

Attach one end of the Diagonal Support Bar (7) to the Upright (2) and then the other end into the predrilled hole on Bottom Bar Back (6).

Repeat this step to attach both Diagonal Support Bars (7).

Connect one Under Bar A (11) with one Under Bar B (12) and then connect this to another Under Bar A (11) to create a longer bar. Repeat this step to get 2 Under Bars. Attach one Under Bar to the front of the polytunnel and one to the back, as shown in the picture above.

8. Next attach the cover (**13**) to the frame using velcro straps attached to the cover.

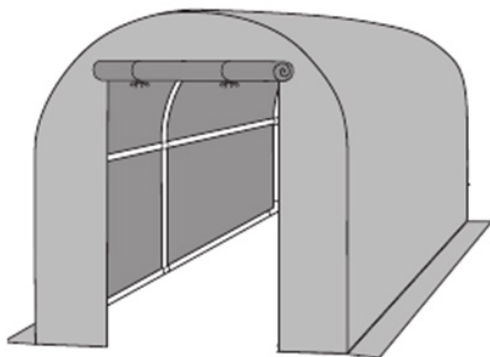

9. Finally, before attaching the Guy Ropes (**14**) we advise digging a trench to sink your poly tunnel into the ground.

This provides additional stability and protection against high winds.



Once you have dug your trench, move the poly tunnel into place and cover the exposed cover at the bottom of the polytunnel with dirt.

Finally attach the guy ropes using the loops on the cover and fix firmly to the ground using the pegs provided.



# TROUBLESHOOTING

## RESOLUTION GUIDE

### WHAT DO I DO IF THERE ARE MISSING PARTS FROM MY ORDER?

If there appears to be any part missing from your order, contact our friendly and helpful Customer Support Team within 7 days of receipt.

**FOR ALL OTHER ISSUES, PLEASE CONTACT OUR  
CUSTOMER SUPPORT TEAM.**

Monster Group (UK) is one of the UK's fastest growing online retailers. We supply a diverse range of products which offer exceptional value for money. We strive to provide the best possible customer experience with free UK delivery across all our products and a Monster Guarantee for 100% satisfaction.

For information regarding this device or other products from our Monster divisions please contact Sales.

#### SALES

TEL: 01347 878 888

EMAIL: hello@monstershop.co.uk

For queries about this device, warranty, returns or reporting faults please contact Support.

#### SUPPORT

TEL: 01347 878 887

EMAIL: help@monstershop.co.uk

Pour plus d'informations concernant cet appareil ou d'autres produits de nos divisions de Monster veuillez utiliser les détails suivants ci-dessous.

#### DÉPARTEMENT COMMERCIAL

TEL: 01347 878 888

EMAIL: bonjour@monstershop.eu

Pour les interrogations concernant cet appareil, la garantie, les retours ou les défauts de déclaration veuillez utiliser les détails suivants ci-dessous.

#### DÉPARTEMENT DE SOUTIEN

TEL: 01347 878 887

EMAIL: help@monstershop.co.uk

Para información sobre este dispositivo u otros productos de nuestras divisiones de Monster por favor use los siguientes detalles.

#### DEPARTAMENTO DE VENTAS

TEL: 01347 878 888

EMAIL: hola@monstershop.eu

Para consultas sobre este dispositivo, la garantía, devoluciones o denuncias de fallos por favor use los siguientes detalles.

#### DEPARTAMENTO DE SOPORTE

TEL: 01347 878 887

EMAIL: help@monstershop.co.uk

Für Informationen bezüglich dieses Geräts oder anderer Produkte aus unserer Monster-Abteilung, benutzen sie die folgenden unten aufgeführten Angaben.

#### VERKAUFABTEILUNG

TEL: 01347 878 888

EMAIL: hallo@monstershop.eu

Für Fragen über dieses Gerät, die Garantie, Rückgaben oder bei Störungen, benutzen sie die folgenden unten aufgeführten Angaben.

#### SUPPORT-ABTEILUNG

TEL: 01347 878 887

EMAIL: help@monstershop.co.uk

Per informazioni riguardanti questo dispositivo o altri prodotti dalle categorie Monster utilizzare i dettagli sotto riportati.

#### DIPARTIMENTO VENDITE

TEL: 01347 878 888

EMAIL: ciao@monstershop.eu

Per domande riguardo dispositivo, garanzia, reso o per riferire di guasti, utilizzare i dettagli sotto riportati.

#### DIPARTIMENTO SUPPORTO

TEL: 01347 878 887

EMAIL: help@monstershop.co.uk

Monster House, Alan Farnaby Way,  
Sheriff Hutton Industrial Estate,  
Sheriff Hutton, York, YO60 6PG  
[www.monstershop.co.uk](http://www.monstershop.co.uk)



 Try **Monster**. Buy **Monster**. Be **Monster**. 