

RATTAN CUBE SET

27320 / 27321 / 27322

INSTRUCTION MANUAL

www.monstershop.co.uk



SPECIFICATION

PRODUCT DESCRIPTION

Thank you for purchasing this Rattan Cube Set, the perfect garden furniture set. Consisting of 4 chairs and 4 stools, along with the glass topped table, this fashionable set provides an ample seating area, ideal for outside gatherings and parties.

For added convenience and to maximise space saving, this set features stools that fit perfectly under the chairs. The chairs are built to be easily folded down to slide effortlessly under the table, meaning this set is the ideal solution to keep a tidy outdoor space.

With a free rain cover, the Rattan Cube Set is protected from light showers, therefore no need to move it indoors! The set also contains UV stabilisers to protect it from the sun.

Please refer to and read the Safe Working Practice to ensure prevention of injury or damage to the Cube Set before starting.

PRODUCT SPECIFICS

CHAIRS

DIMENSIONS:	53cm (W) x 53cm (L) x 90cm (H)
MATERIAL:	Rattan, Powder-Coated Steel
WEIGHT CAPACITY:	140kg
CUSHION THICKNESS:	5cm

TABLE

DIMENSIONS:	110cm (W) x 110cm (L) x 74cm (H)
MATERIAL:	Rattan, Powder-Coated Steel, 5mm Tempered Glass
WEIGHT CAPACITY:	80kgs



STOOLS

DIMENSIONS:	53cm (W) x 53cm (L) x 40cm (H)
MATERIAL:	Rattan, Powder-Coated Steel
WEIGHT CAPACITY:	120kg
CUSHION THICKNESS:	5cm

Monster Group UK Limited's liability will be limited to the commercial value of the product only.

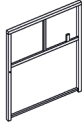
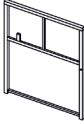
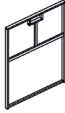
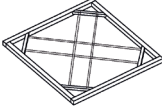
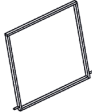
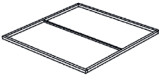

SPECIFICATION

ITEM CONTENTS

Part Ref.	Picture	Description	Quantity
A		Chair - Left Hand Panel	4
B		Chair - Right Hand Panel	4
C		Chair - Rear Panel	4
D		Chair - Base Panel	4
E		Chair Back	4
F		Table - Top Panel	1
G		Table - Legs	1



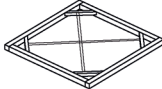
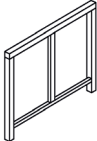
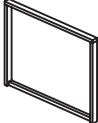
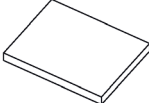
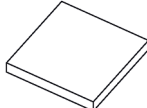



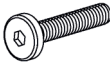

SPECIFICATION

ITEM CONTENTS

Part Ref.	Picture	Description	Quantity
H		Table Bottom Panel	2
I		Stool - Top	4
J		Stool - Legs	8
K		Stool - Side Panels	8
L		Seat Cushion	8
M		Stool Cushion	4
N		Glass - Table Top	1

SPECIFICATION

ITEM CONTENTS

Part Ref.	Picture	Description	Quantity
1		Washer	114
2		Bolt 6*40	18
3		Bolt 6*20	24
4		Bolt 6*30	68
5		Cap Nut	4
6		Plastic Washer	8
7		Bracket	8
8		Spanner	1
9		Allen Key	2

SAFETY ADVICE

SAFE WORKING PRACTICE

Please read through the Safe Working Practice to ensure prevention of injury or damage to the device.

- Do not use this product for anything other than its intended purposes.
- Ensure you have read and fully understood the instruction manual and safety advice before using this product.
- We recommend that at least two people work together for the assembly.
- Do not apply bodyweight to this product before it is installed.
- Keep small parts away from children.
- Ensure this product is fitted correctly.
- Use this product on a flat surface.
- Do not expose this product to fire.
- Do not allow this product to get excessively hot.
- Do not exceed the maximum weight capacity of the furniture.

USER GUIDE

ASSEMBLY INSTRUCTIONS

To assist with the assembly of your Rattan furniture, we recommend you only half tighten the nuts & bolts when first assembling the furniture.

Once you have assembled the complete set, you can then fully tighten all the nuts & bolts.

1

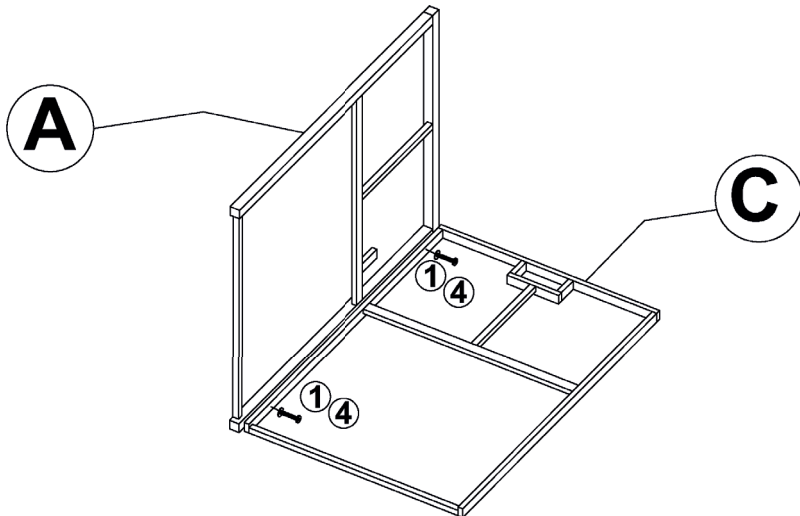

USER GUIDE

ASSEMBLY INSTRUCTIONS

2

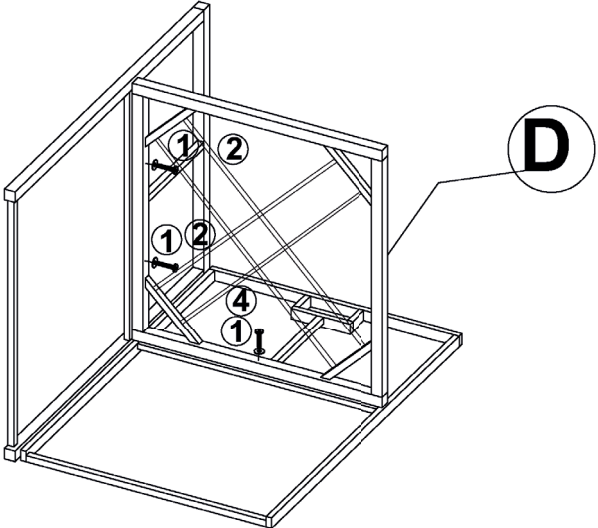

3

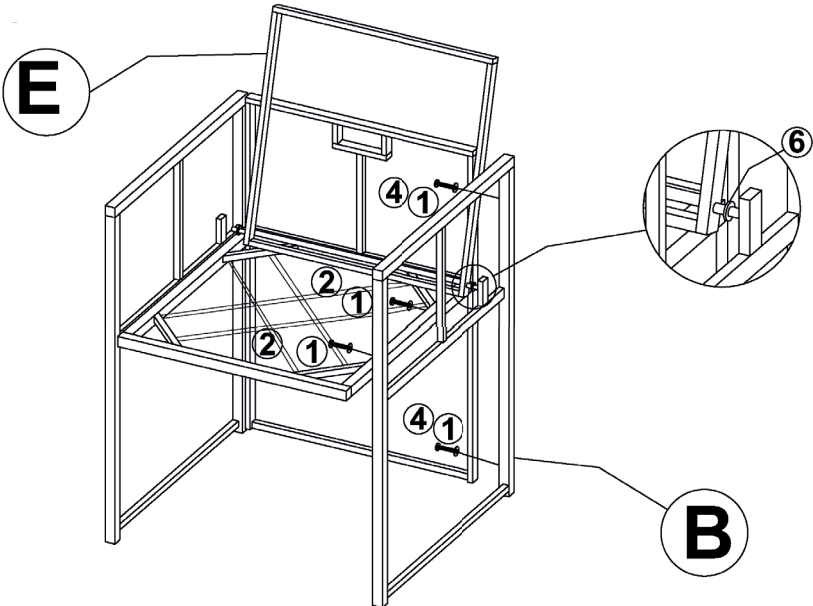

USER GUIDE

ASSEMBLY INSTRUCTIONS

4

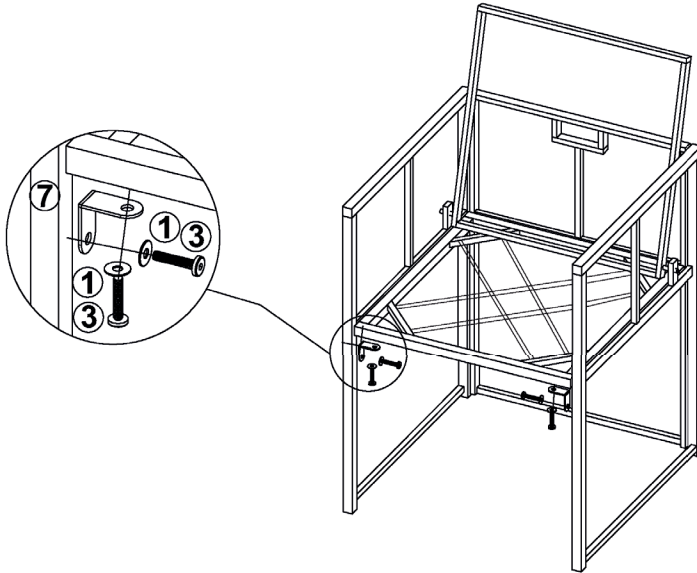

5

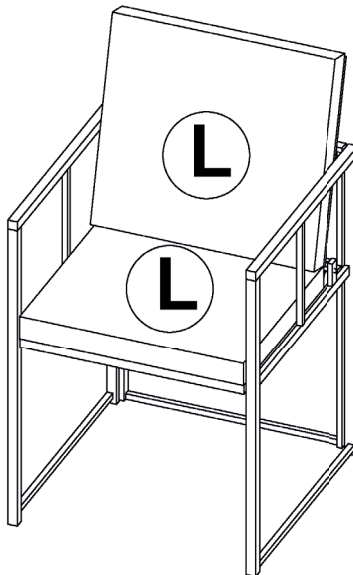

USER GUIDE

ASSEMBLY INSTRUCTIONS

6

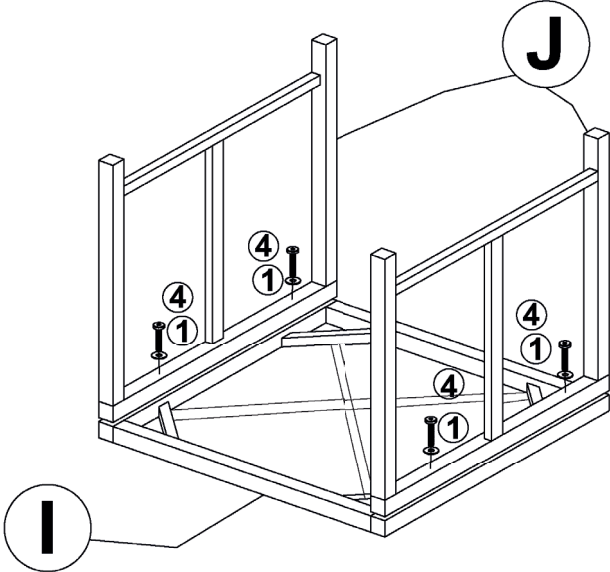

7

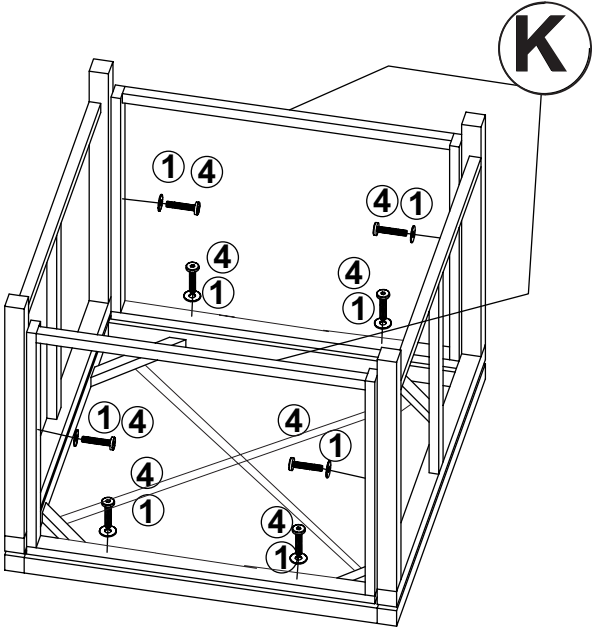

USER GUIDE

ASSEMBLY INSTRUCTIONS

8

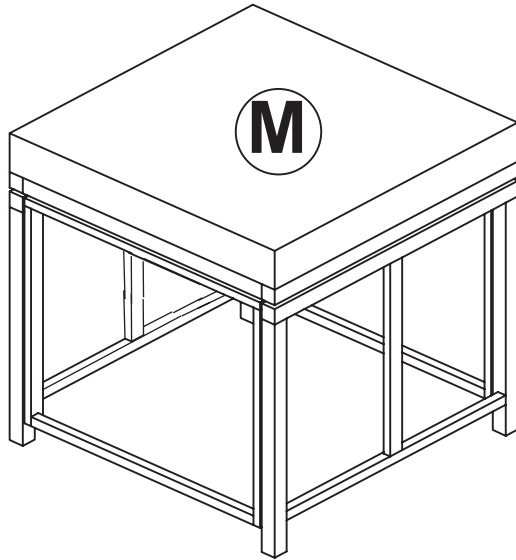

9

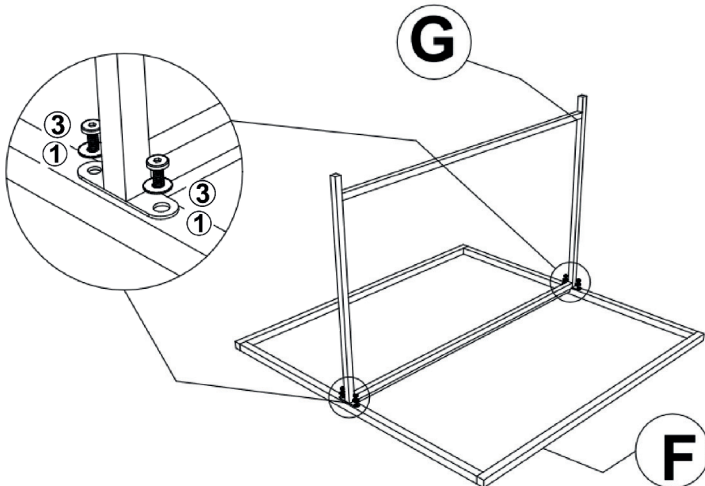

USER GUIDE

ASSEMBLY INSTRUCTIONS

10

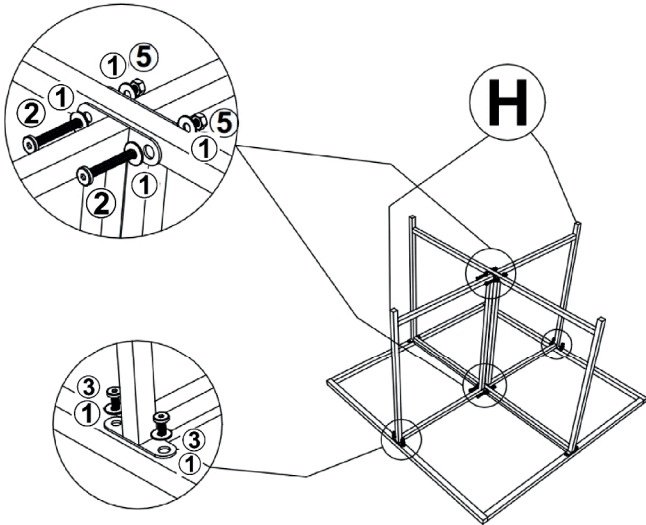

11

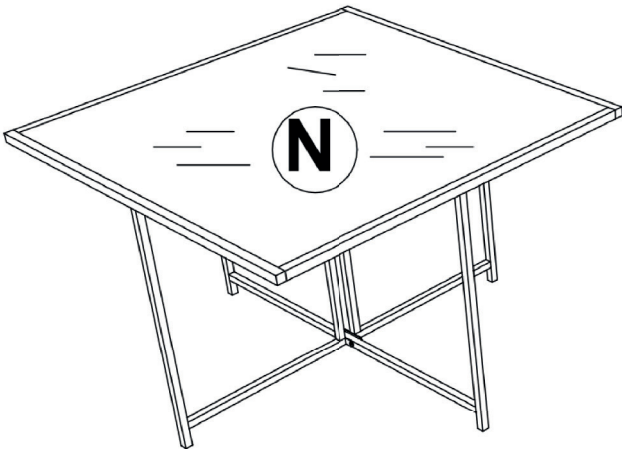

USER GUIDE

ASSEMBLY INSTRUCTIONS

12

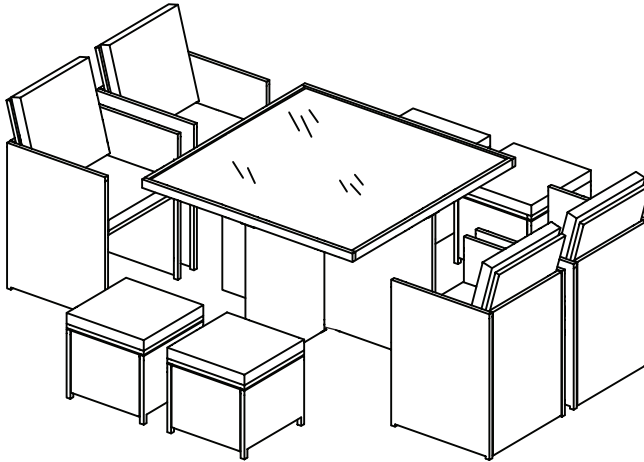

Ensure all the nuts & bolts are fully tightened before using the furniture for the first time.

USER GUIDE

MAINTENANCE

- To clean the Rattan Cube Set, use a soft cloth, warm water, and mild detergent to wipe down. To clean the cushions, wipe them down with a damp cloth. Use mild detergent and a soft cloth in case of stubborn stains.
- Use the complimentary rain cover to protect the Rattan Cube Set when the set is not in use. Ensure the set is stored indoors in a cool, dry location during winter, to prevent mold and mildew growth on the cushions.
- Check the screws and bolts regularly and tighten if required.

TROUBLESHOOTING

RESOLUTION GUIDE

WHAT DO I DO IF THERE ARE MISSING PARTS FROM MY ORDER?

If there appears to be any part missing from your order, contact our friendly and helpful Customer Support Team within 7 days of receipt.

WHAT DO I DO IF THE FURNITURE STARTS TO WOBBLE/MOVE?

The screws and bolts need to be checked regularly to ensure they are tight and secure. Retighten any screws or bolts that are loose.

**FOR ALL OTHER ISSUES, PLEASE CONTACT OUR
CUSTOMER SUPPORT TEAM.**

SPÉCIFICATIONS

DESCRIPTION DU PRODUIT

Merci pour votre achat. Ce salon de jardin cube en rotin sera parfait pour votre jardin. Composé de 4 chaises et de 4 tabourets, ainsi que d'une table en verre, cet ensemble tendance offre une grande surface d'assise, idéale pour les réunions de famille et les fêtes en plein air.

Afin de vous offrir plus de flexibilité et de maximiser votre espace, cet ensemble inclus des tabourets qui s'adaptent parfaitement sous les chaises. Les chaises sont conçues pour être facilement repliées et glissées sans effort sous la table, vous permettant de garder votre espace extérieur bien rangé.

Grâce à une housse de protection incluse, le salon de jardin cube en rotin sera protégé des petites averses, et vous n'aurez donc pas besoin de le déplacer à l'intérieur ! Le salon contient également des stabilisateurs d'UV pour le protéger du soleil.

Avant de commencer, veuillez lire les pratiques de travail sécuritaires et vous y référer afin d'éviter toute blessure ou tout dommage sur le salon de jardin cube.

DÉTAILS DU PRODUIT

CHAISES

DIMENSIONS :	53cm (l) x 53cm (L) x 90cm (H)
MATERIAUX :	Rotin, Acier thermolaqué
CHARGE MAXIMALE :	140kg
ÉPAISSEUR DES COUSSINS :	5cm

TABLE

DIMENSIONS:	110cm (l) x 110cm (L) x 74cm (H)
MATERIAUX :	Rotin, Acier thermolaqué, Verre trempé 5mm
CHARGE MAXIMALE :	80kgs







TABOURETS

DIMENSIONS:	53cm (l) x 53cm (L) x 40cm (H)
MATERIAUX :	Rotin, Acier thermolaqué
CHARGE MAXIMALE :	120kg
ÉPAISSEUR DES COUSSINS:	5cm

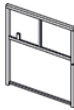
La responsabilité de Monster Group UK Limited sera limitée à la valeur commerciale du produit uniquement.

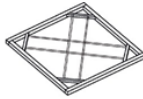
SPÉCIFICATIONS

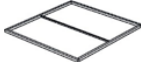

CONTENU

Ref de la pièce.	Illustration	Description	Quantité
A		Chaise - Panneau gauche	4
B		Chaise - Panneau droit	4
C		Chaise - Panneau arrière	4
D		Chaise - Panneau de base	4
E		Dossier de chaise	4
F		Table - Panneau supérieur	1
G		Table - Pieds	1

La responsabilité de Monster Group UK Limited sera limitée à la valeur commerciale du produit.



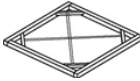
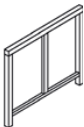
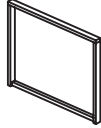
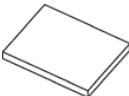
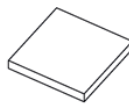



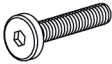

SPÉCIFICATIONS

CONTENU

Part Ref.	Picture	Description	Quantity
H		Panneau inférieur de la table	2
I		Tabouret - dessus	4
J		Tabouret - Supports	8
K		Tabouret - Panneaux latéraux	8
L		Coussin de siège	8
M		Coussin de tabouret	4
N		Verre-Plateau de table	1

SPÉCIFICATIONS

CONTENU

Part Ref.	Picture	Description	Quantity
1		Rondelle	114
2		Boulon 6*40	18
3		Boulon 6*20	24
4		Boulon 6*30	68
5		Écrou borgne	4
6		Rondelle en plastique	8
7		Support	8
8		Clé à molette	1
9		Clé Allen	2

CONSEILS DE SÉCURITÉ

PRATIQUE DE TRAVAIL SÉCURITAIRE

Veillez lire les consignes de sécurité afin d'éviter toute blessure ou tout dommage sur le produit.

- N'utilisez pas ce produit à d'autres fins que celles pour lesquelles il a été conçu.
- Assurez-vous d'avoir bien lu et compris le manuel d'utilisation et les conseils de sécurité avant d'utiliser ce produit.
- Nous vous conseillons d'assembler ce produit à l'aide de deux personnes ou plus.
- N'appliquez pas le poids de votre corps sur ce produit avant qu'il ne soit installé.
- Gardez les petites pièces hors de portée des enfants.
- Assurez-vous que ce produit soit monté correctement.
- Utilisez ce produit sur une surface plane.
- N'exposez pas ce produit au feu.
- Ne laissez pas ce produit devenir excessivement chaud.
- Ne dépassez pas la capacité de charge maximale du meuble.

MODE D'EMPLOI

INSTRUCTIONS DE MONTAGE

Pour faciliter le montage de votre meuble en rotin, nous vous recommandons de ne serrer les écrous et les boulons qu'à moitié lors de la première étape de son assemblage.

Une fois que vous aurez assemblé l'ensemble complet, vous pourrez alors serrer complètement tous les écrous et boulons.

1

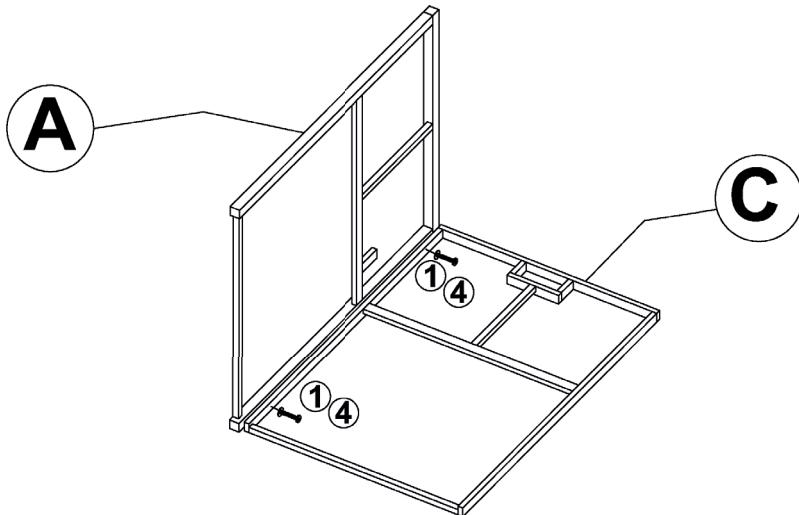

MODE D'EMPLOI

INSTRUCTIONS DE MONTAGE

2

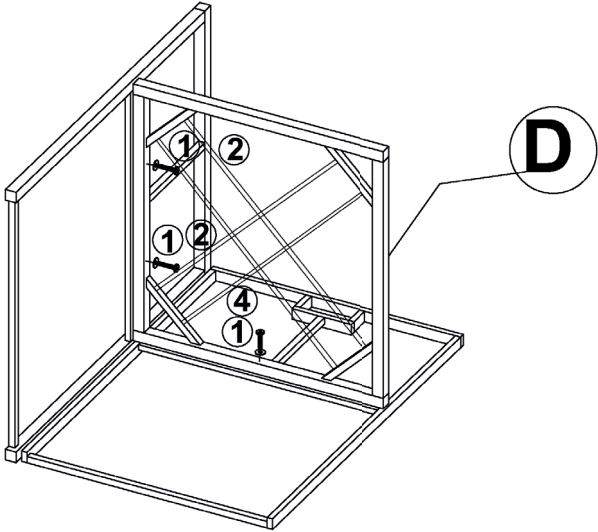

3

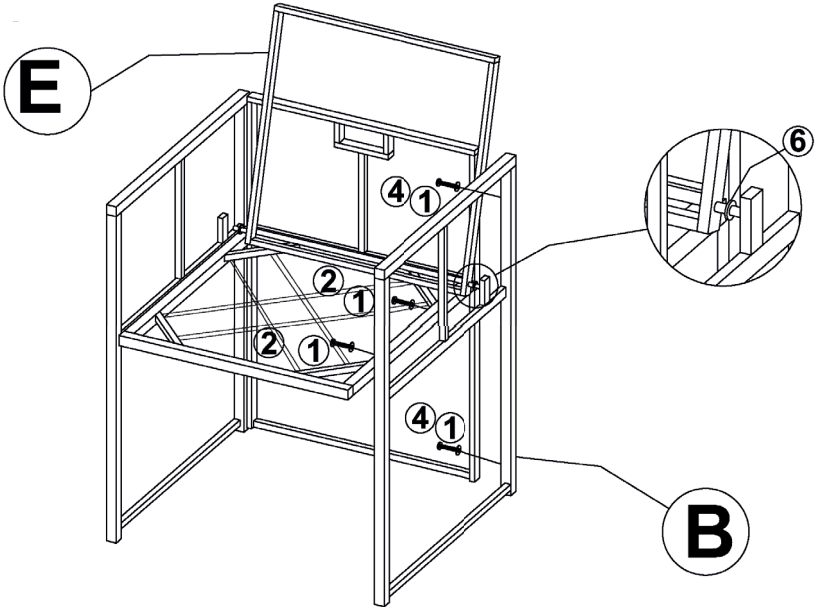

MODE D'EMPLOI

INSTRUCTIONS DE MONTAGE

4

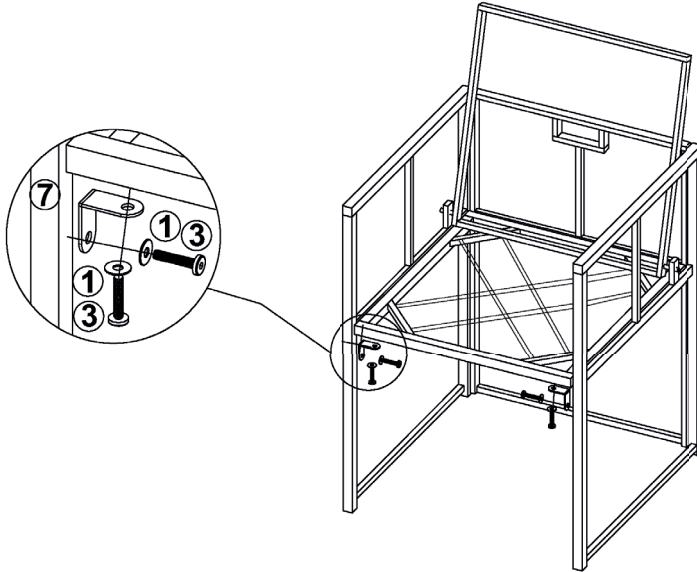

5

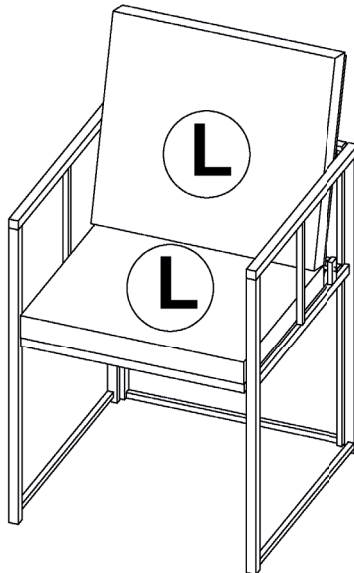

MODE D'EMPLOI

INSTRUCTIONS DE MONTAGE

6

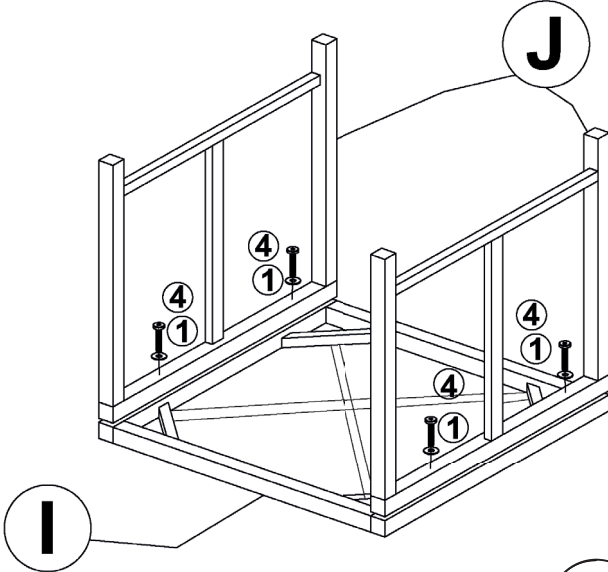

7

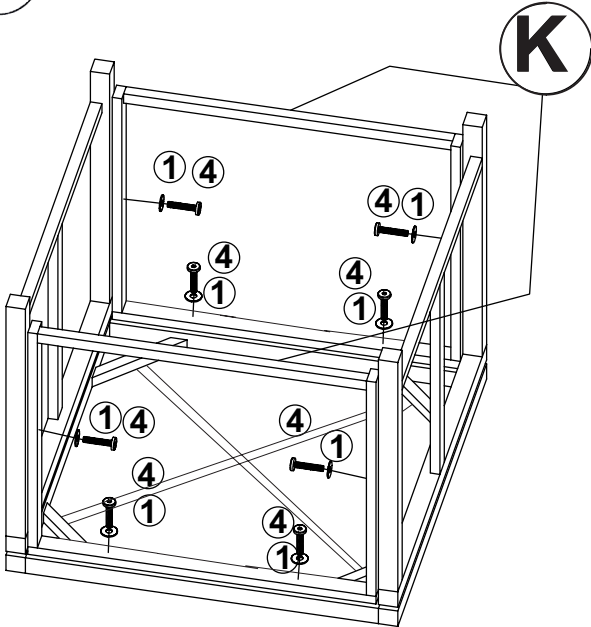

MODE D'EMPLOI

INSTRUCTIONS DE MONTAGE

8

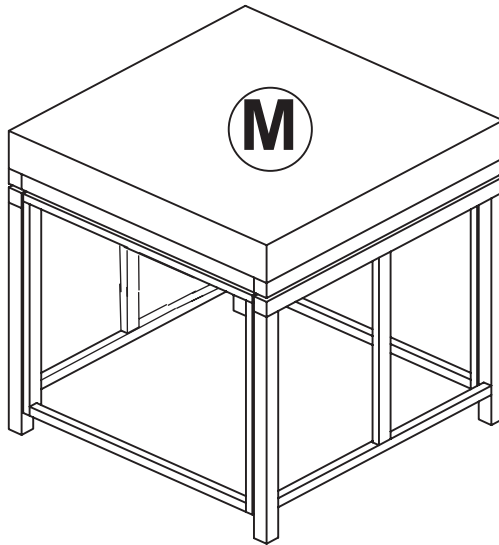

9

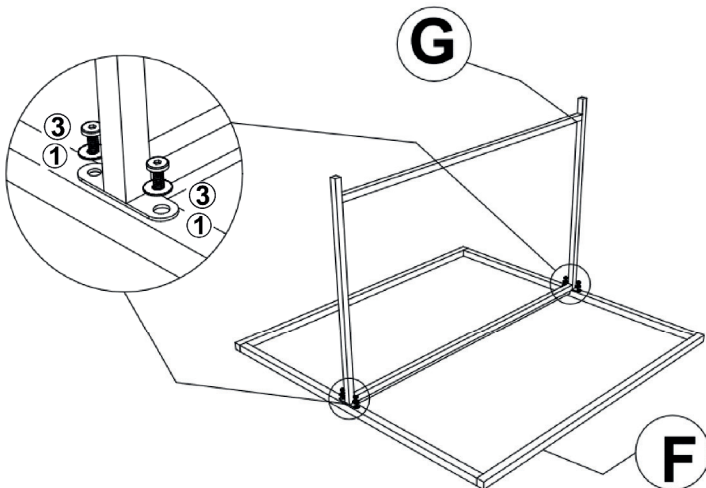

MODE D'EMPLOI

INSTRUCTIONS DE MONTAGE

10

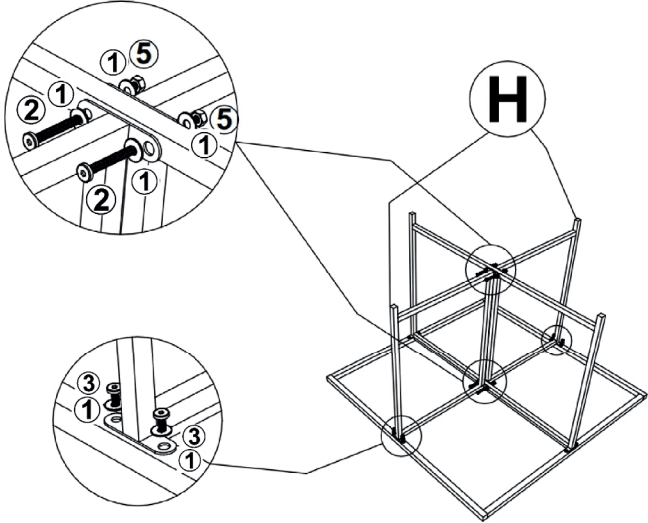

11

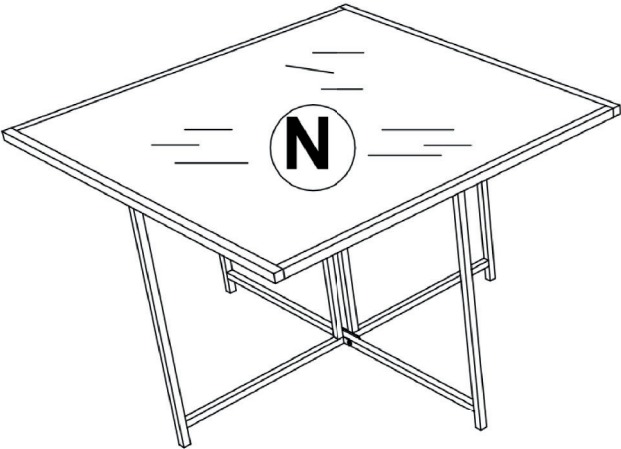

MODE D'EMPLOI

INSTRUCTIONS DE MONTAGE

12

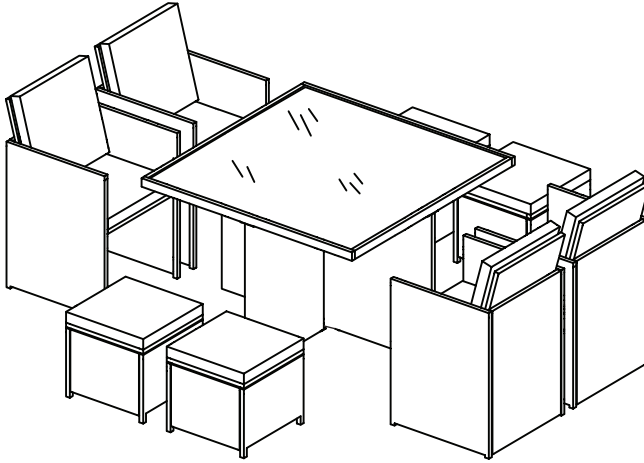

Assurez-vous que tous les écrous et boulons soient bien serrés avant d'utiliser le salon pour la première fois.

MODE D'EMPLOI

ENTRETIEN

- Pour nettoyer ce salon en rotin, utilisez un chiffon doux, de l'eau chaude et un détergent doux. Pour nettoyer les coussins, essuyez-les avec un chiffon humide. En cas de taches tenaces, utilisez un détergent doux et un chiffon doux.
- Utilisez la housse de protection incluse pour protéger le salon en rotin lorsqu'il n'est pas utilisé. Veillez à ce que l'ensemble soit stocké à l'intérieur dans un endroit frais et sec pendant l'hiver, afin d'éviter la formation de moisissures sur les coussins.
- Vérifiez régulièrement les vis et les boulons et resserrez-les si nécessaire.

DÉPANNAGE

GUIDE DE RÉOLUTION

QUE FAIRE S'IL MANQUE DES PIÈCES À MA COMMANDE ?

Si une pièce semble manquer à votre commande, veuillez contacter notre équipe du service client dans les 7 jours suivant la réception de votre commande.

QUE FAIRE SI LE MEUBLE N'EST PAS STABLE/ BOUGE ?

Les vis et les boulons doivent être vérifiés régulièrement et être resserrés et sécurisés au besoin.

**POUR TOUT AUTRE PROBLÈME, VEUILLEZ
CONTACTER NOTRE ÉQUIPE DU SERVICE CLIENT.**



SPEZIFIKATIONEN

PRODUKTBESCHREIBUNG

Wir freuen uns sehr, dass Sie sich für dieses Rattan Cube Set entschieden haben - das perfekte Gartenmöbelset. Mit den 4 Stühlen, 4 Hockern und dem Tisch mit Glasplatte bietet dieses moderne Set einen großzügigen Sitzbereich, perfekt für Partys im Freien.

Für zusätzliche Bequemlichkeit und um den Platzbedarf zu maximieren, verfügt dieses Set über Hocker, die perfekt unter die Stühle passen. Die Stühle sind so konstruiert, dass sie sich mühelos unter den Tisch schieben lassen, dieses Set hat das perfekte Design für einen aufgeräumten Außenbereich.

Damit dieses Set vor leichten Regenschauern geschützt ist und nicht nach drinnen transportiert werden muss, haben wir eine kostenlose Regenhülle beigegefügt. Um das Set von der Sonne zu schützen, sind auch UV-Stabilisatoren enthalten.

Bitte lesen Sie die Hinweise zum sicheren Arbeitsverfahren durch, um Verletzungen oder Schäden an dem Set zu vermeiden, bevor Sie es benutzen.

PRODUKTSPEZIFIKA

STÜHLE

ABMESSUNGEN: 53cm (B) x 53cm (L) x 90cm (H)
MATERIAL: Rattan, pulverbeschichteter Stahl
MAX. GEWICHT: 140kg
KISSENSTÄRKE: 5cm

TISCH

ABMESSUNGEN: 110cm (B) x 110cm (L) x 74cm (H)
MATERIAL: Rattan, pulverbeschichteter Stahl, 5 mm gehärtetes
MAX. GEWICHT: Glas 80 kg







HOCKER

ABMESSUNGEN: 53cm (B) x 53cm (L) x 40cm (H)
MATERIAL: Rattan, pulverbeschichteter Stahl
MAX. GEWICHT: 120kg
KISSENSTÄRKE: 5cm

Die Haftung von Monster Group UK Limited ist auf den Handelswert des Produkts beschränkt.

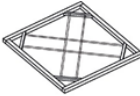
SPEZIFIKATION

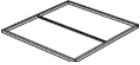

PRODUKTMERKMALE

Teil Ref.	Bild	Beschreibung	Menge
A		Stuhl - linkes Paneel	4
B		Stuhl - Rechtes Paneel	4
C		Stuhl - Rückwand	4
D		Stuhl - Bodenplatte	4
E		Chair Back Stuhl Rücklehne	4
F		Tisch - Deckplatte	1
G		Tisch - Beine	1

Die Haftung von Monster Group UK Limited ist auf den Handelswert des Produkts beschränkt.



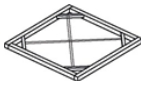
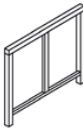
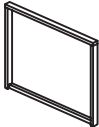
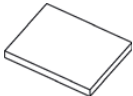
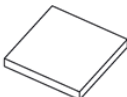



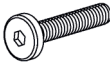

SPEZIFIKATION

PRODUKTMERKMALE

Teil Ref.	Bild	Beschreibung	Menge
H		Untere Platte des Tisches	2
I		Hocker - oben	4
J		Hocker - Beine	8
K		Hocker - Seitenteile	8
L		Sitzkissen	8
M		Hocker-Kissen	4
N		Glas - Tischplatte	1

SPEZIFIKATION

PRODUKTMERKMALE

Teil Ref.	Bild	Beschreibung	Menge
1		Beilagsscheibe	114
2		Schraube 6*40	18
3		Schraube 6*20	24
4		Schraube 6*30	68
5		Mutter	4
6		Kunststoff-Scheibe	8
7		Halterung	8
8		Schraubenschlüssel	1
9		Inbusschlüssel	2

SICHERHEITSHINWEIS

SICHERES ARBEITEN

Bitte lesen Sie sich die Hinweise zum sicheren Arbeitsverfahren durch, um Verletzungen oder Schäden an dem Set zu vermeiden.

- Verwenden Sie dieses Produkt nicht für andere als die vorgesehenen Zwecke.
- Vergewissern Sie sich, dass Sie die Gebrauchsanweisung und die Sicherheitshinweise gelesen und verstanden haben, bevor Sie dieses Produkt benutzen.
- Wir empfehlen, dass mindestens zwei Personen bei der Montage zusammenarbeiten.
- Belasten Sie dieses Produkt nicht mit Ihrem Körpergewicht, bevor es fertig installiert ist.
- Halten Sie Kleinteile von Kindern fern.
- Vergewissern Sie sich, dass dieses Produkt korrekt montiert ist.
- Verwenden Sie dieses Produkt nur auf einer ebenen Fläche.
- Setzen Sie dieses Produkt keinem Feuer aus.
- Achten Sie darauf, dass das Gerät nicht übermäßig heiß wird.
- Überschreiten Sie nicht die maximale Gewichtskapazität des Möbelstücks.

BENUTZERLEITFADEN

MONTAGEANLEITUNGEN

Um die Montage Ihrer Rattanmöbel zu erleichtern, empfehlen wir Ihnen, die Schrauben und Muttern beim ersten Zusammenbau nur halb anzuziehen.

Sobald Sie den kompletten Satz zusammengesetzt haben, können Sie alle Schrauben und Muttern fest anziehen.

1

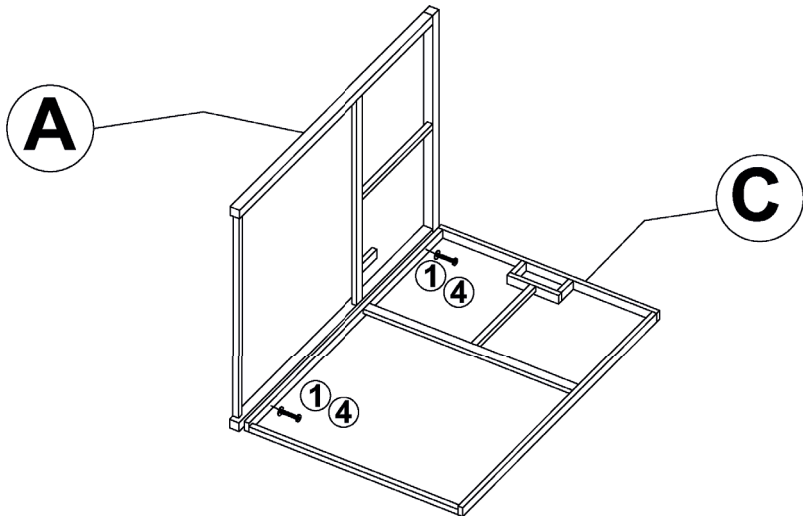

BENUTZERLEITFADEN

MONTAGEANLEITUNGEN

2

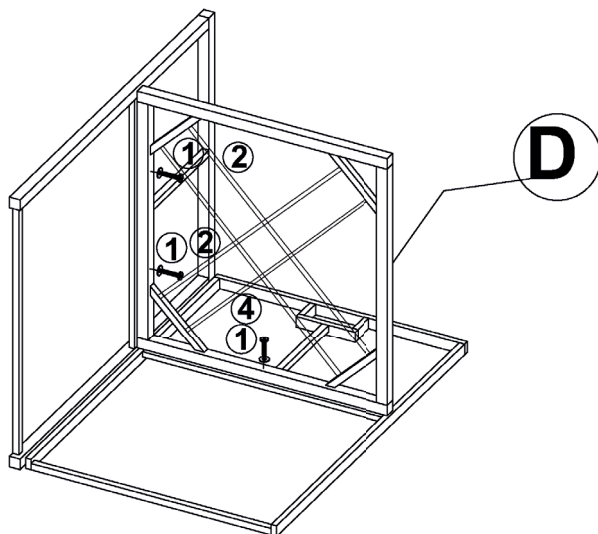

3

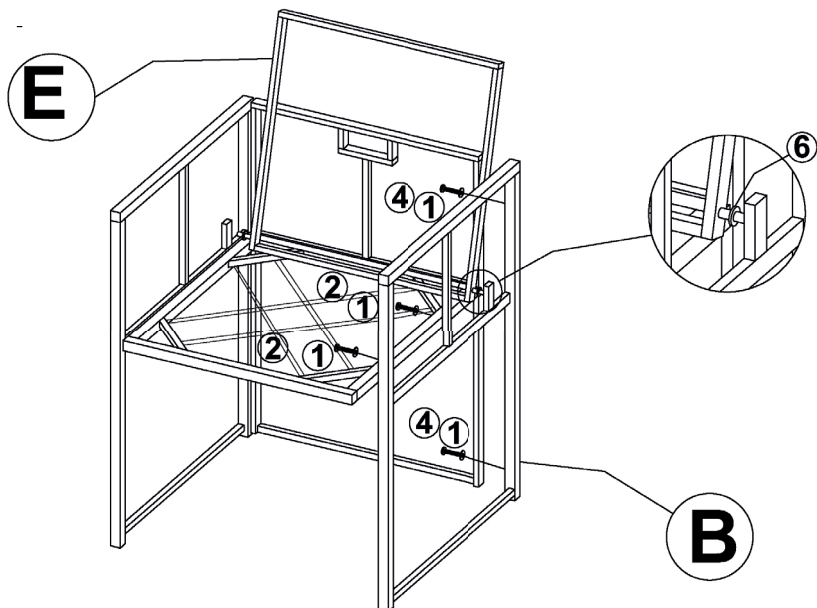

BENUTZERLEITFADEN

MONTAGEANLEITUNGEN

4

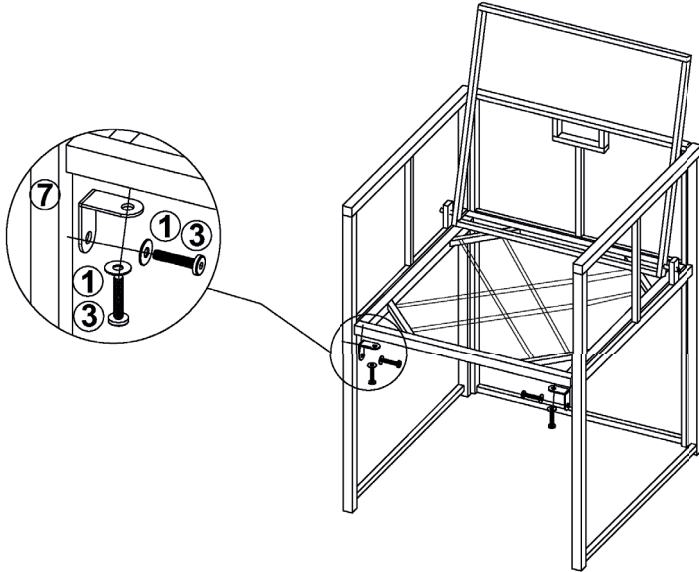

5

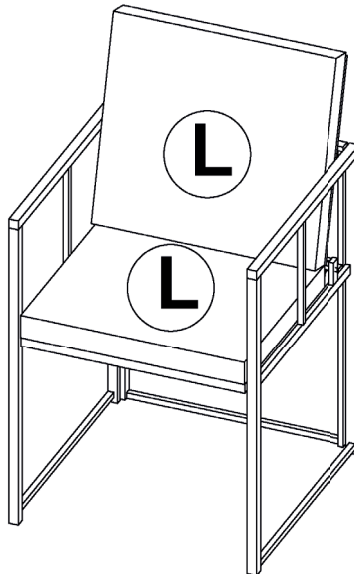

BENUTZERLEITFADEN

MONTAGEANLEITUNGEN

6

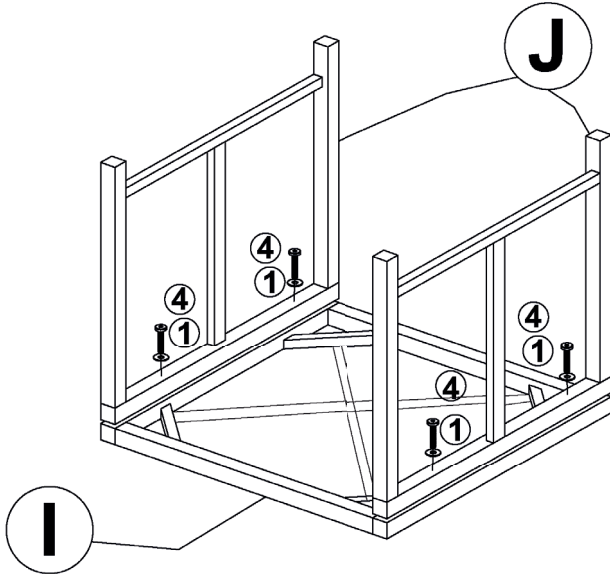

7

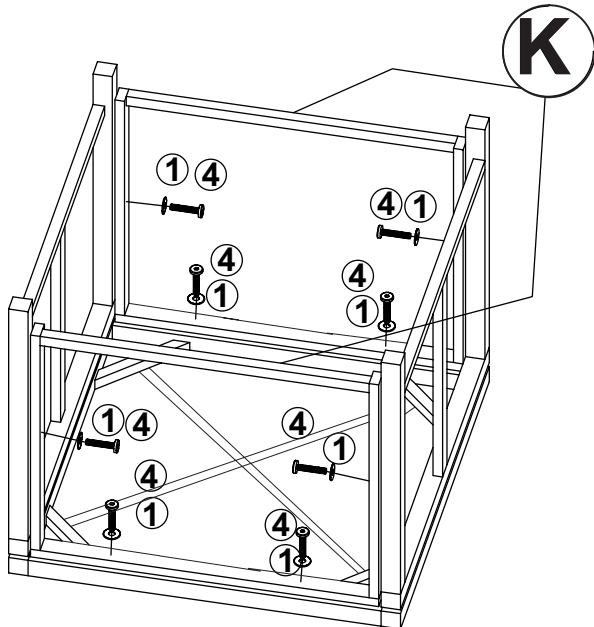

BENUTZERLEITFADEN

MONTAGEANLEITUNGEN

8

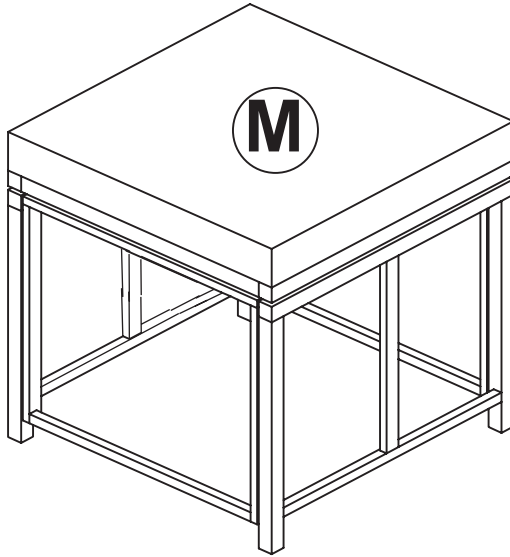

9

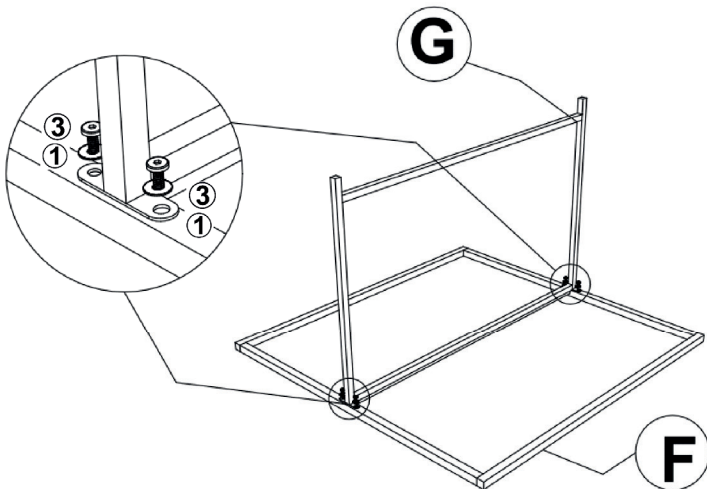

BENUTZERLEITFADEN

MONTAGEANLEITUNGEN

10

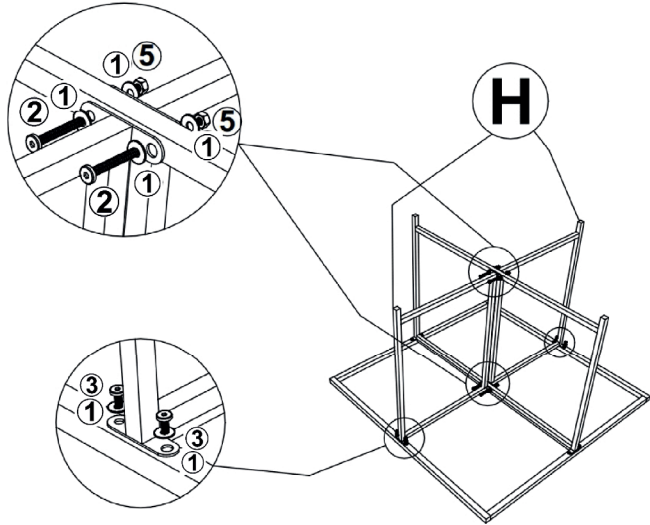

11

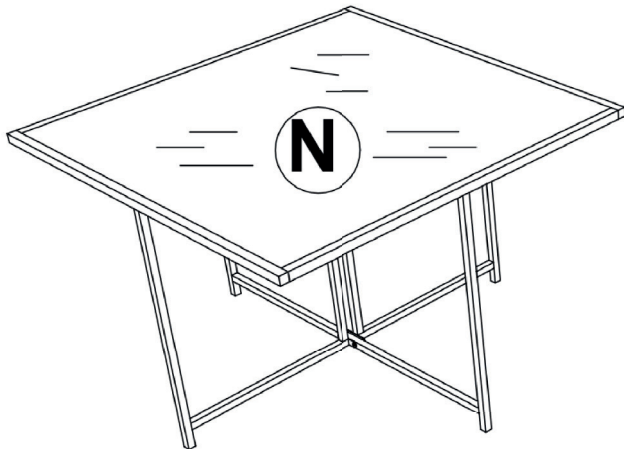

BENUTZERLEITFADEN

MONTAGEANLEITUNGEN

12

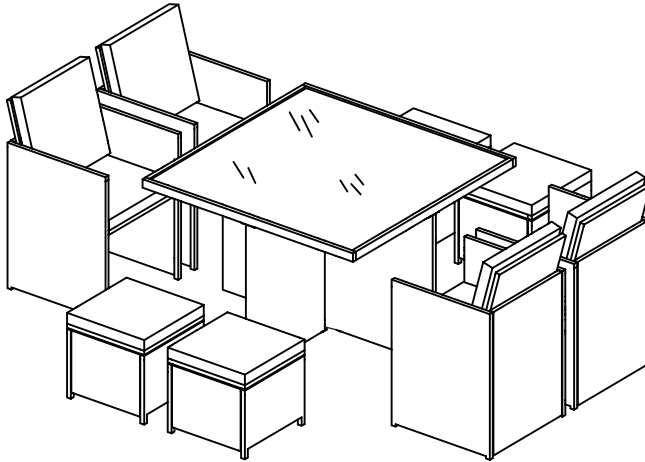

Vergewissern Sie sich, dass alle Schrauben und Muttern fest angezogen sind, bevor Sie das Möbelstück zum ersten Mal benutzen.

BENUTZERLEITFADEN

WARTUNG

- Verwenden Sie zur Reinigung des Rattan Cube Sets ein weiches Tuch, warmes Wasser und ein mildes Reinigungsmittel. Reinigen Sie die Kissen mit einem feuchten Tuch. Verwenden Sie bei hartnäckigen Flecken ein mildes Reinigungsmittel und ein weiches Tuch.
- Wenn das Set nicht in Gebrauch ist, können Sie es mit der mitgelieferten Regenhülle schützen. Stellen Sie sicher, dass das Set im Winter an einem kühlen, trockenen Ort verstaut wird, um Schimmel und Mehltau auf den Kissen zu vermeiden.
- Überprüfen Sie die Schrauben und Bolzen regelmäßig und ziehen Sie sie bei Bedarf nach.

FEHLERBEHEBUNG

LÖSUNGSGUIDE

WAS MACHE ICH, WENN BEI MEINER BESTELLUNG TEILE FEHLEN?

Falls bei Ihrer Bestellung ein Teil zu fehlen scheint, wenden Sie sich bitte innerhalb von 7 Tagen nach Erhalt der Ware an unser freundliches und hilfsbereites Kundenservice-Team.

WAS SOLL ICH TUN, WENN DIE MÖBEL ANFANGEN ZU WACKELN/ SCHWANKEN?

Die Schrauben und Bolzen müssen regelmäßig überprüft werden, um sicherzustellen, dass sie fest und sicher sitzen. Ziehen Sie alle lockeren Schrauben und Bolzen nach.

**FÜR ALLE ANDEREN FRAGEN WENDEN SIE SICH BITTE AN
UNSEREN KUNDENDIENST.**



ESPECIFICACIONES

DESCRIPCIÓN DEL PRODUCTO

Gracias por comprar este juego de cubos de ratán, el juego de muebles de jardín perfecto. Compuesto por 4 sillas y 4 taburetes, junto con la mesa con superficie de cristal, este conjunto de moda proporciona una amplia zona de asientos, ideal para reuniones y fiestas en el exterior.

Para mayor comodidad y para maximizar el ahorro de espacio, este conjunto cuenta con taburetes que encajan perfectamente bajo las sillas. Las sillas se pueden plegar fácilmente para deslizarse sin esfuerzo bajo la mesa, lo que significa que este conjunto es la solución ideal para mantener un espacio exterior ordenado.

Con una funda de lluvia gratuita, el conjunto de cubos de ratán estará protegido de lluvias ligeras, por lo que no es necesario trasladarlo al interior. El conjunto también cuenta con estabilizadores de rayos UV para protegerlo del sol.

Antes de comenzar, por favor consulte y lea las Prácticas de Trabajo Seguro para asegurar la prevención de lesiones o daños al Set de Cubos.

ESPECIFICACIONES DEL PRODUCTO

SILLAS

DIMENSIONES:	53cm (Ancho) x 53cm (Largo) x 90cm (Alto)
MATERIAL: CAPACIDAD	Ratán, Acero Recubierto de Polvo
DE PESO:	140kg
GROSOR DEL COJÍN:	5cm

MESA

DIMENSIONES:	110cm (Ancho) x 110cm (Largo) x 74cm (Alto)
MATERIAL: CAPACIDAD	Acero Recubierto de Polvo, Vidrio Templado de 5 mm
DE PESO:	80kgs







TABURETES

DIMENSIONES:	53cm (Ancho) x 53cm (Largo) x 40cm (Alto)
MATERIAL: CAPACIDAD	Ratán, Acero Recubierto de Polvo
DE PESO:	120kg
GROSOR DEL COJÍN:	5cm

La responsabilidad de Monster Group UK Limited se limitará únicamente al valor comercial del producto.

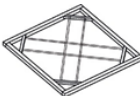
ESPECIFICACIONES

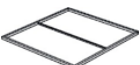



CARACTERÍSTICAS DEL PRODUCTO

Referencia de Parte	Foto	Descripción	Cantidad
A		Silla – Panel Izquierdo	4
B		Silla - Panel Derecho	4
C		Silla – Panel Trasero	4
D		Silla – Panel de la Base	4
E		Respaldo de la Silla	4
F		Mesa – Panel Superior	1
G		Mesa - Patas	1

La responsabilidad de Monster Group UK Limited estará limitada únicamente al valor comercial del producto.

ESPECIFICACIONES

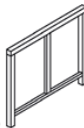
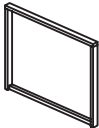
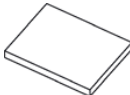
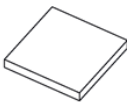
CARACTERÍSTICAS DEL PRODUCTO

Referencia de Parte	Foto	Descripción	Cantidad
H		Panel Inferior de la Mesa	2
I		Taburete – Parte Superior	4
J		Taburete - Patas	8
K		Taburete – Paneles Laterales	8
L		Cojín del Asiento	8
M		Cojín de Taburete	4
N		Vidrio - Superficie de Mesa	1

ESPECIFICACIONES

CARACTERÍSTICAS DEL PRODUCTO

Referencia de Parte	Foto	Descripción	Cantidad
1		Arandela	114
2		Perno 6*40	18
3		Perno 6*20	24
4		Perno 6*30	68
5		Tuerca de Cierre	4
6		Arandela de Plástico	8
7		Soporte	8
8		Llave Inglesa	1
9		Llave Allen	2

CONSEJOS DE SEGURIDAD

PRÁCTICAS DE TRABAJO SEGURAS

Por favor, lea las Prácticas Seguras de Trabajo para asegurar la prevención de lesiones o daños al dispositivo.

- No utilice este producto para fines distintos a los previstos.
- Asegúrese de haber leído y comprendido completamente el manual de instrucciones y los consejos de seguridad antes de utilizar este producto.
- Recomendamos que al menos dos personas trabajen juntas para el ensamblado.
- No aplique el peso de su cuerpo a este producto antes de instalarlo.
- Mantenga las piezas pequeñas fuera del alcance de los niños.
- Asegúrese de que este producto está correctamente montado.
- Utilice este producto en una superficie plana.
- No exponga este producto al fuego.
- No permita que este producto se caliente excesivamente.
- No supere la capacidad de peso máxima del mueble.

GUÍA DEL USUARIO

INSTRUCCIONES DE ENSAMBLAJE

Para facilitar el ensamblado de su mueble de ratán, le recomendamos que sólo apriete a medias los pernos y tornillos cuando monte el mueble por primera vez.

Una vez que haya ensamblado el conjunto completo, puede apretar por completo todos los tornillos y pernos.

1

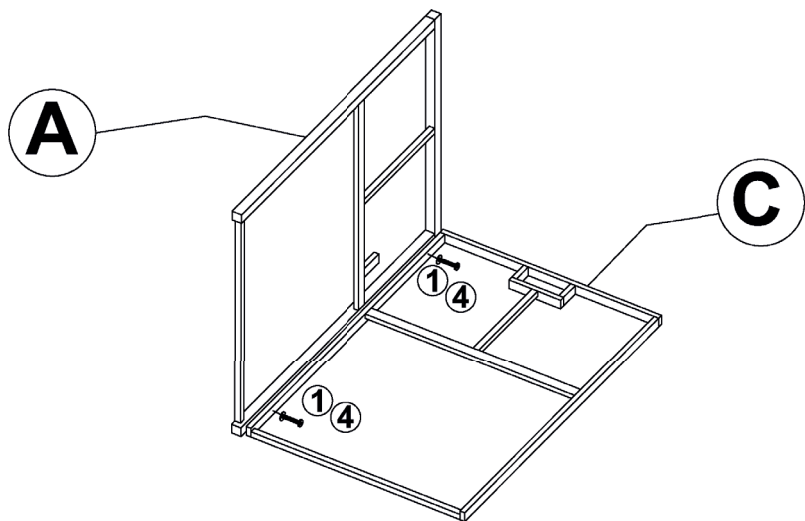

GUÍA DEL USUARIO

INSTRUCCIONES DE ENSAMBLAJE

2

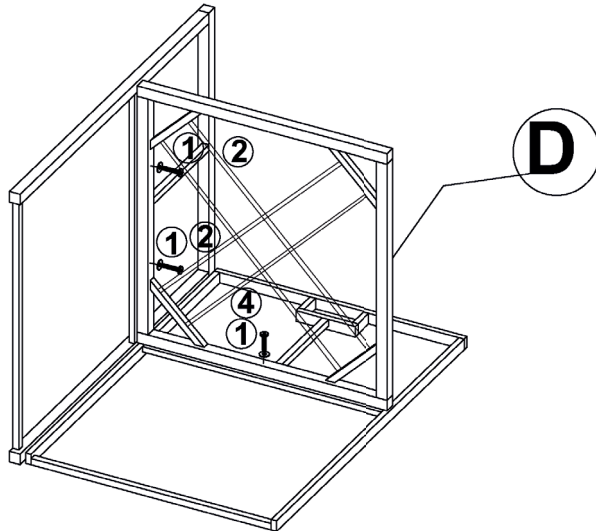

3

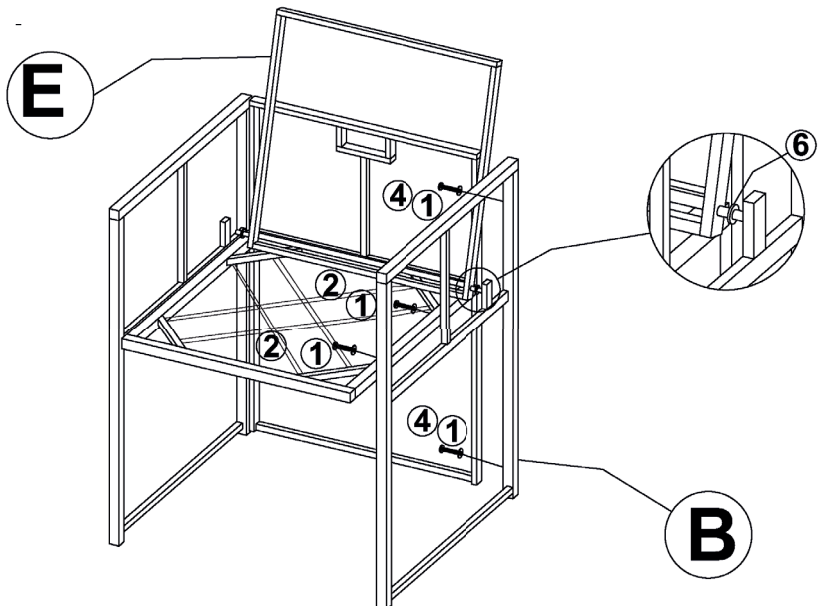

GUÍA DEL USUARIO

INSTRUCCIONES DE ENSAMBLAJE

4

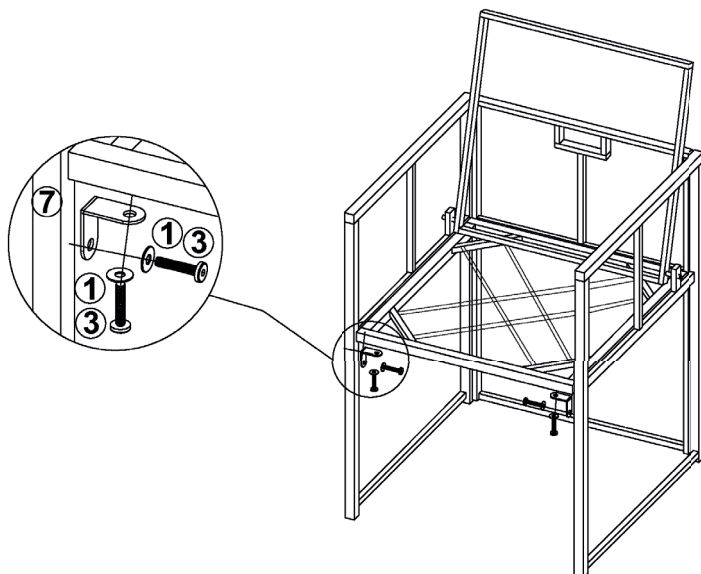

5

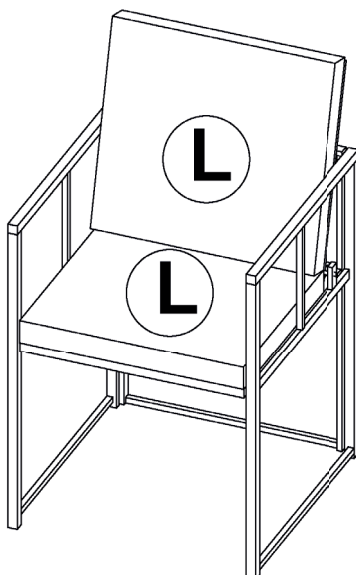

GUÍA DEL USUARIO

INSTRUCCIONES DE ENSAMBLAJE

6

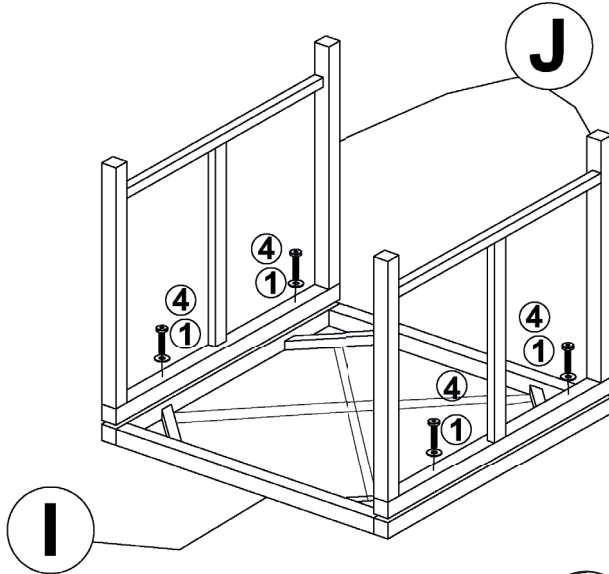

7

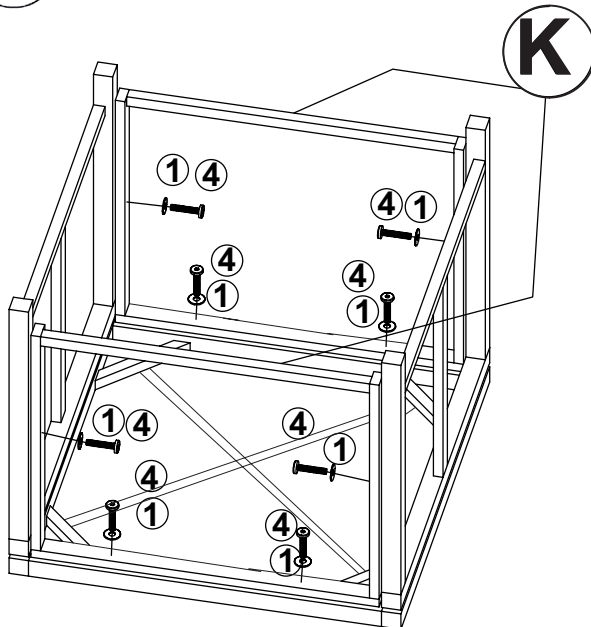

GUÍA DEL USUARIO

INSTRUCCIONES DE ENSAMBLAJE

8

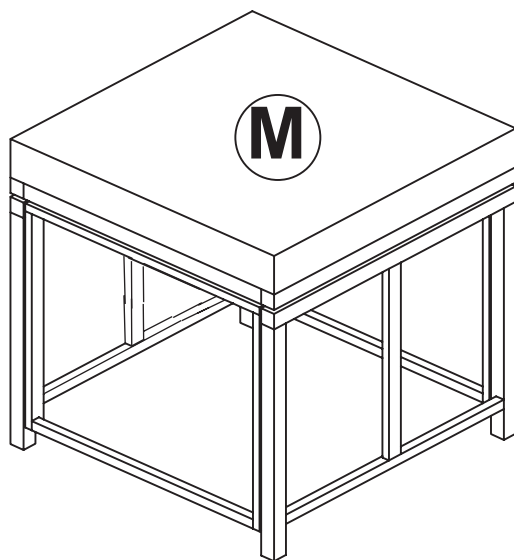

9

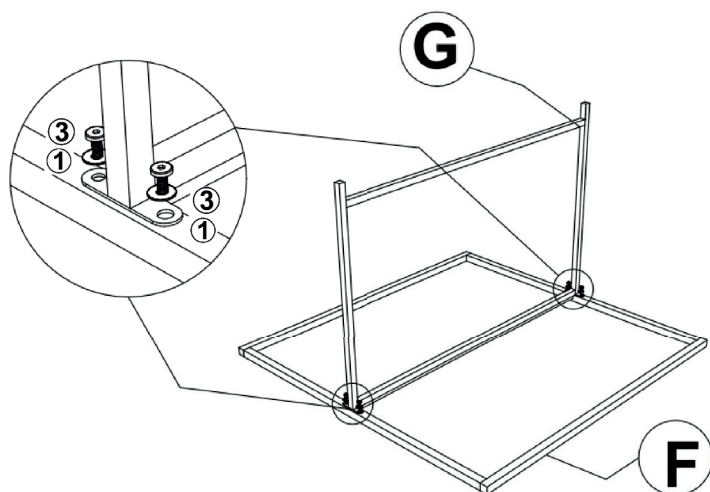

GUÍA DEL USUARIO

INSTRUCCIONES DE ENSAMBLAJE

10

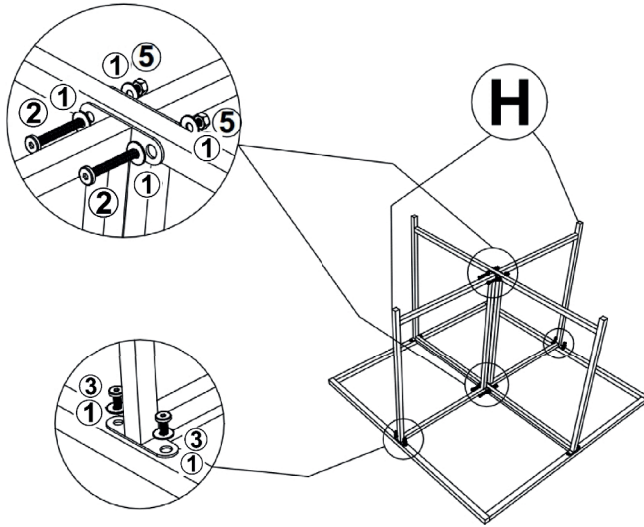

11

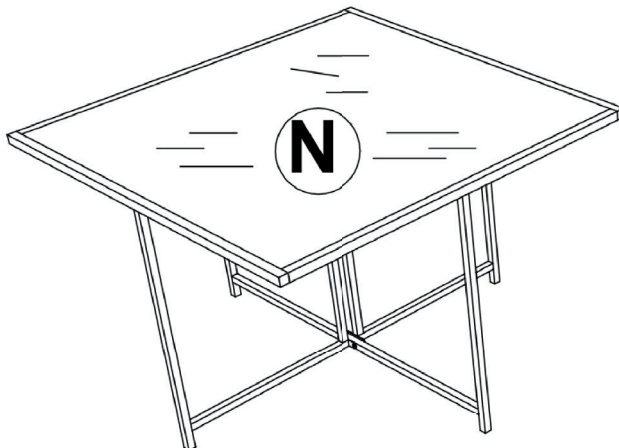

GUÍA DEL USUARIO

INSTRUCCIONES DE ENSAMBLAJE

12

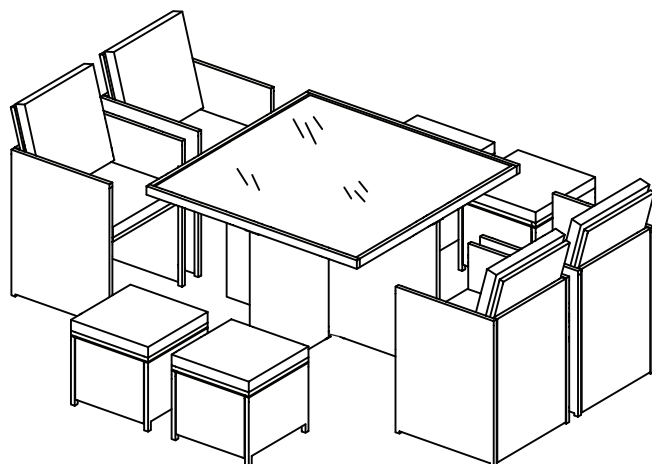

Asegúrese de que todas las tuercas y tornillos estén bien apretados antes de utilizar el mueble por primera vez.

GUÍA DEL USUARIO

MANTENIMIENTO

- Para limpiar el juego de cubos de ratán, utilice un paño suave, agua tibia y un detergente suave. Para limpiar los cojines, páselos un paño húmedo. Utilice un detergente y un paño suaves en caso de manchas persistentes.
- Utilice la funda de lluvia de regalo para proteger el juego de cubos de ratán cuando no lo utilice. Asegúrese de guardarlo en un lugar fresco y seco durante el invierno, para evitar la aparición de moho en los cojines.
- Revise los tornillos y pernos regularmente y apriételes si es necesario.

SOLUCIÓN DE PROBLEMAS

GUÍA DE RESOLUCIÓN

¿QUÉ HAGO SI FALTAN PIEZAS EN MI PEDIDO?

Si parece que falta alguna pieza en su pedido, póngase en contacto con nuestro amable y servicial equipo de atención al cliente en los siguientes 7 días siguientes a la entrega.

¿QUÉ HAGO SI EL MUEBLE EMPIEZA A TAMBALEARSE/MOVERSE?

Los tornillos y pernos deben ser revisados regularmente para asegurarse de que están apretados y seguros. Vuelva a apretar los tornillos o pernos que estén flojos.

CUALQUIER OTRO PROBLEMA, PÓNGASE EN CONTACTO CON NUESTRO EQUIPO DE ATENCIÓN AL CLIENTE.

SPECIFICHE

DESCRIZIONE DEL PRODOTTO

Grazie per aver acquistato questo set di mobili Rattan, il perfetto complemento d'arredo per il vostro giardino. Composto da 4 sedie e 4 sgabelli, insieme a un tavolo con ripiano in vetro, questo set all'ultima moda offre un abbondante numero di posti a sedere, ideale per riunioni e feste all'aperto. Per una maggiore praticità e per massimizzare gli spazi, gli sgabelli di questo set si inseriscono perfettamente sotto alle sedie. Le sedie sono state pensate per poter essere ripiegate facilmente e scivolare sotto il tavolo, motivi per cui questo set è la soluzione ideale per mantenere uno spazio esterno perfettamente ordinato.

Grazie alla copertura antipioggia in omaggio, il set di mobili Rattan rimarrà protetto da lievi acquazzoni, quindi non sarà necessario spostarlo al chiuso! Il set contiene inoltre stabilizzatori UV per proteggerlo dal sole.

Prima di iniziare, si prega di consultare e leggere la sezione 'avvertenze di sicurezza' per evitare lesioni o danni al set di mobili.

SPECIFICHE DEL PRODOTTO

SEDIE

DIMENSIONI:	53cm (La) x 53cm (Lu) x 90cm (A) Rattan, acciaio rivestito a
MATERIALE:	polvere
CAPACITÀ DI CARICO:	140kg
SPESSORE DEI CUSCINI:	5cm

TAVOLO

DIMENSIONI:	110cm (La) x 110cm (Lu) x 74cm (A)
MATERIALE:	Rattan, acciaio rivestito a polvere, vetro temperato da 5 mm
CAPACITÀ DI CARICO:	80kg







SGABELLI

DIMENSIONI:	53cm (La) x 53cm (Lu) x 40cm (A)
MATERIALE:	Rattan, acciaio rivestito a polvere
CAPACITÀ DI CARICO:	120kg
SPESSORE DEI CUSCINI:	5cm

N.B. Monster Group UK Limited limita la sua responsabilità al solo valore commerciale del prodotto.

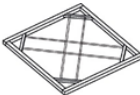



SPECIFICHE TECNICHE

LISTA COMPONENTI

Rif. parti	Immagine	Descrizione	Quantità
A		Sedia - Pannello sinistro	4
B		Sedia - Pannello destro	4
C		Sedia - Pannello posteriore	4
D		Sedia - Pannello di base	4
E		Schienale della sedia	4
F		Tavolo - Pannello superiore	1
G		Tavolo - Gambe	1

SPECIFICHE TECNICHE

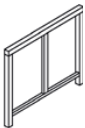
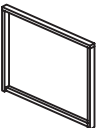
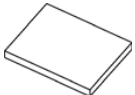
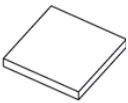





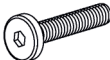

LISTA COMPONENTI

Rif. parti	Immagine	Descrizione	Quantità
H		Pannello inferiore del tavolo	2
I		Sgabello - Parte superiore	4
J		Sgabello - Gambe	8
K		Sgabello - Pannello laterale	8
L		Cuscini della sedia	8
M		Cuscini dello sgabello	4
N		Vetro - Piano del tavolo	1

La responsabilità di Monster Group UK Limited sarà limitata al solo valore commerciale del prodotto.

SPECIFICHE TECNICHE

LISTA COMPONENTI

Rif. parti	Immagine	Descrizione	Quantità
1		Rondelle	114
2		Bulloni 6*40	18
3		Bulloni 6*20	24
4		Bulloni 6*30	68
5		Dadi	4
6		Rondelle in plastica	8
7		Staffe	8
8		Chiave inglese	1
9		Brugole	2

CONSIGLI PER LA SICUREZZA

PRATICHE DI LAVORO SICURO

Si prega di leggere le seguenti istruzioni per prevenire infortuni o danni agli oggetti.

- Non utilizzare questo prodotto per scopi diversi da quelli previsti.
- Verificare di aver letto e compreso appieno il manuale di istruzioni e i consigli sulla sicurezza prima di utilizzare il prodotto.
- Si consiglia la collaborazione di almeno due persone per il montaggio.
- Non applicare il peso corporeo al prodotto prima di aver completato l'installazione.
- Mantenere le parti più piccole lontano dalla portata dei bambini.
- Assicurarsi di montare correttamente il prodotto.
- Installare il prodotto su una superficie piana.
- Non esporre il prodotto al fuoco.
- Non lasciar riscaldare eccessivamente il prodotto.
- Non superare la capacità di carico massima dei mobili.

GUIDA UTENTE

ISTRUZIONI PER IL MONTAGGIO

Per facilitare l'assemblaggio dei vostri mobili Rattan, si consiglia di stringere solo a metà i dadi e i bulloni quando si assembleranno i pezzi.

Una volta completato il set, potrete stringere completamente tutti i dadi e i bulloni.

1

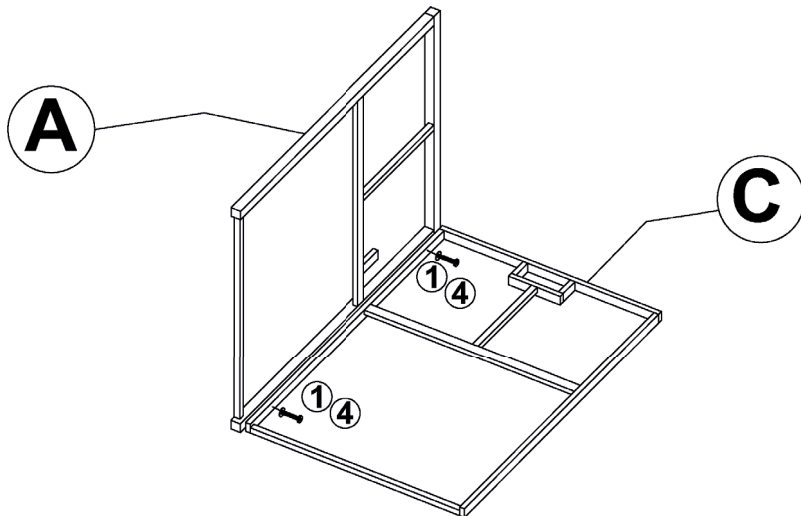

GUIDA UTENTE

ISTRUZIONI PER IL MONTAGGIO

2

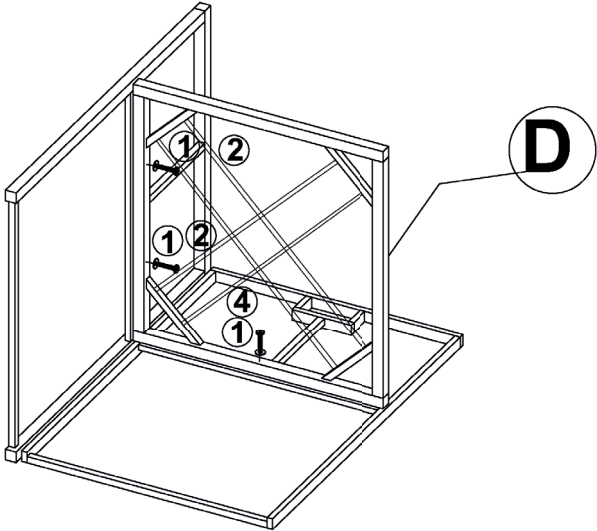

3

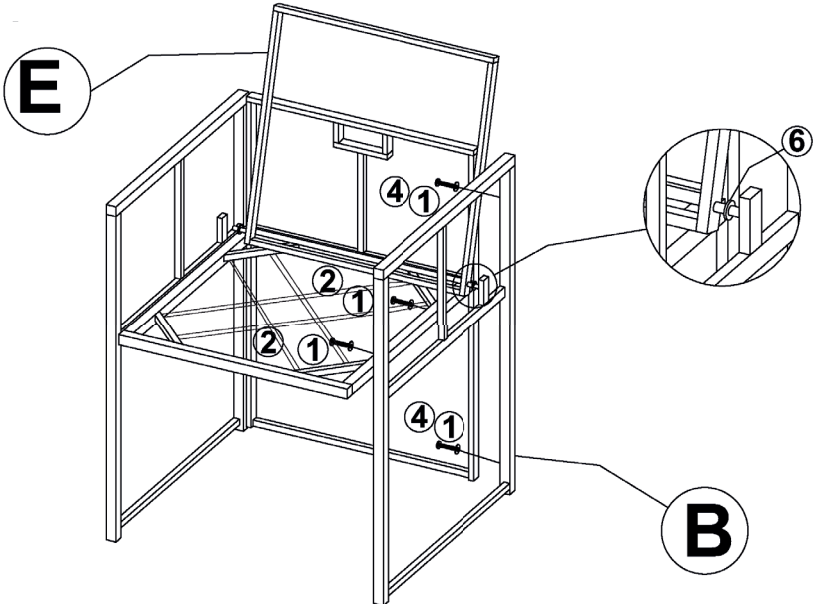

GUIDA UTENTE

ISTRUZIONI PER IL MONTAGGIO

4

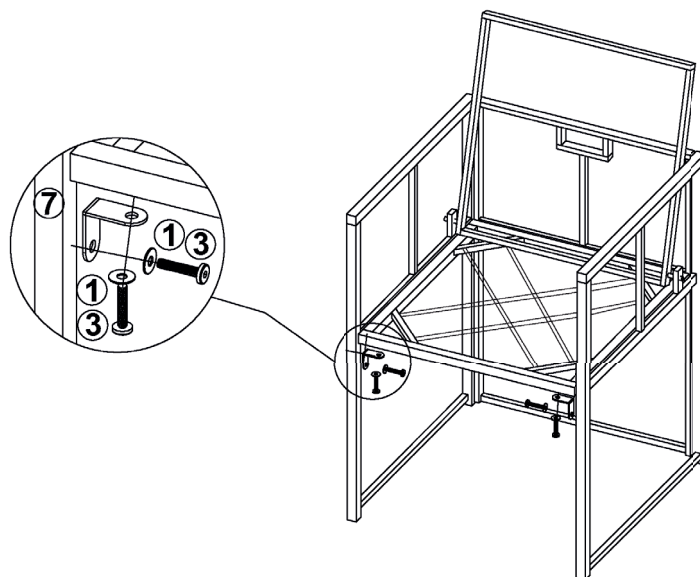

5

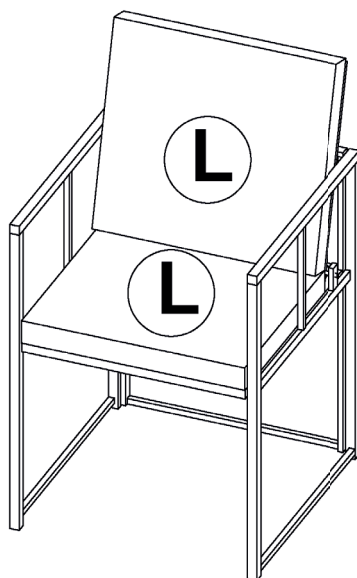

GUIDA UTENTE

ISTRUZIONI PER IL MONTAGGIO

6

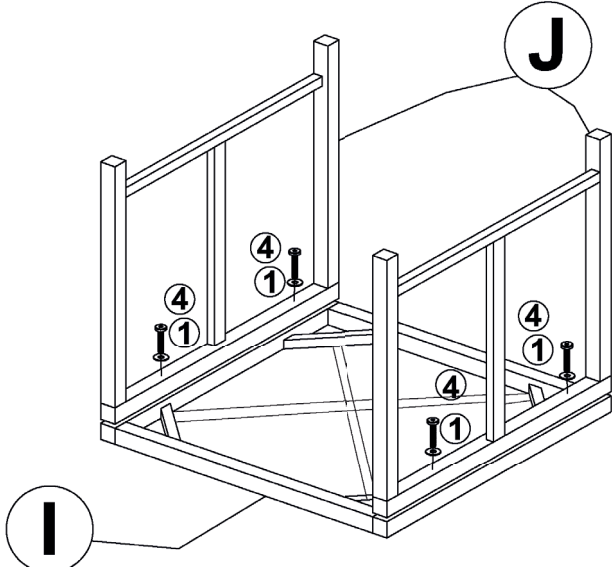

7

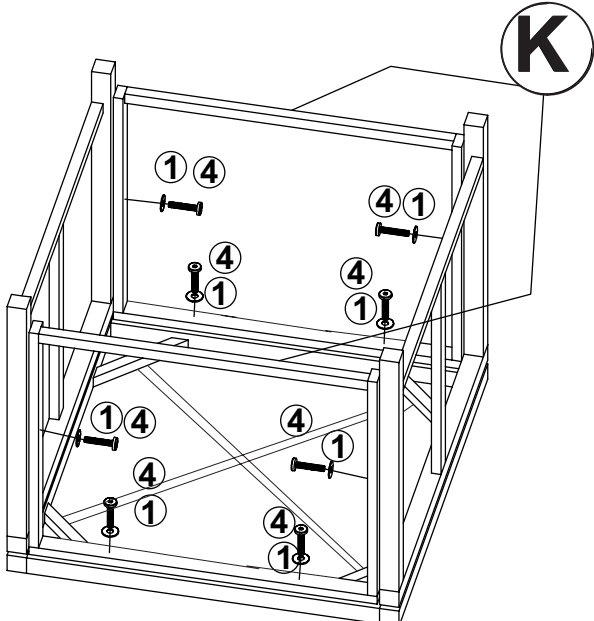

GUIDA UTENTE

ISTRUZIONI PER IL MONTAGGIO

8

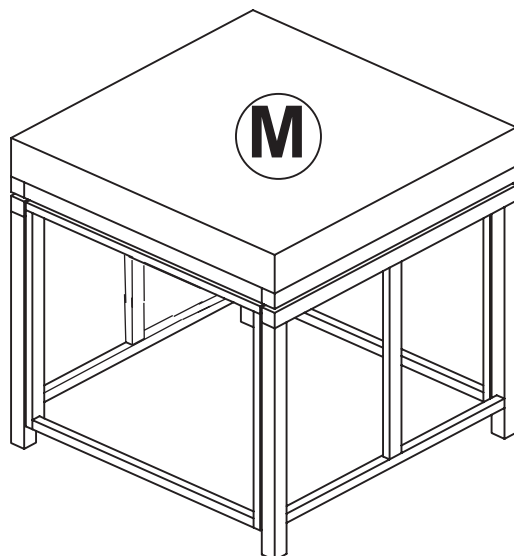

9

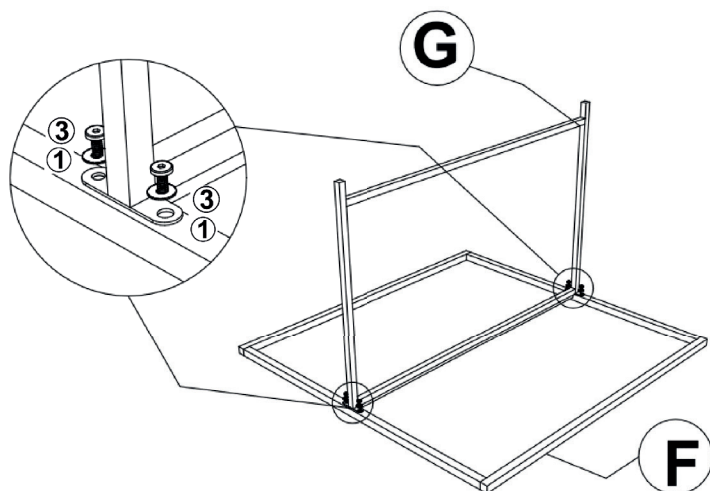

GUIDA UTENTE

ISTRUZIONI PER IL MONTAGGIO

10

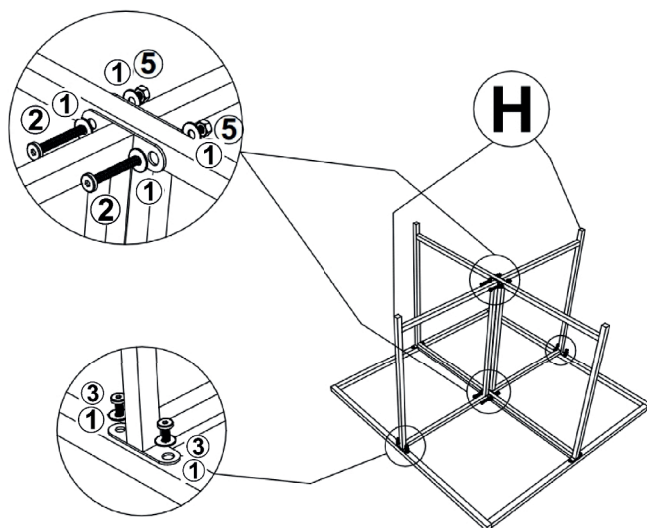

11

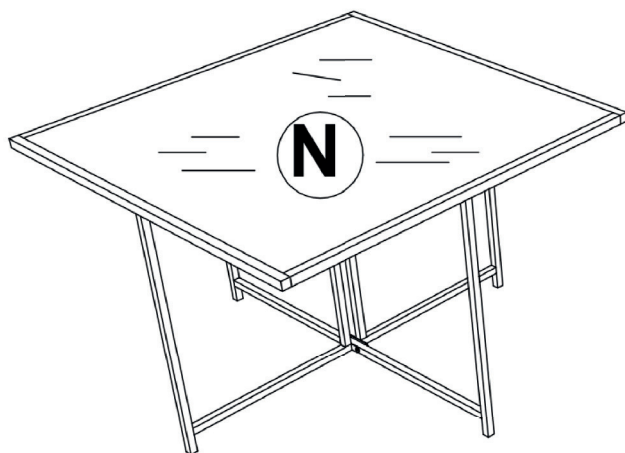

GUIDA UTENTE

ISTRUZIONI PER IL MONTAGGIO

12

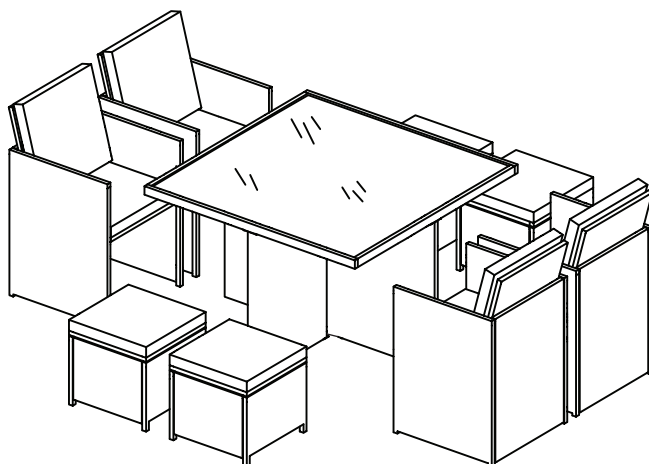

Assicurarsi di serrare perfettamente i dadi e i bulloni prima di utilizzare i mobili per la prima volta.

GUÍA DEL USUARIO

MANTENIMIENTO

- Per pulire il set di mobili Rattan, utilizzare un panno morbido, acqua calda e un detergente delicato. Per pulire i cuscini, strofinarli con un panno umido. In caso di macchie ostinate, utilizzare un detergente delicato insieme a un panno morbido.
- Utilizzare la copertura anti-pioggia in dotazione per proteggere il set di mobili Rattan quando non viene adoperato. Assicurarsi di conservare il set al chiuso durante l'inverno, in un luogo fresco e asciutto, per evitare la formazione di muffa e funghi sui cuscini.
- Controllare regolarmente le viti e i bulloni, e stringerli se necessario.

RISOLUZIONE DEI PROBLEMI

GUIDA ALLA RISOLUZIONE DEI PROBLEMI

COSA DEVO FARE SE MANCANO DEI PEZZI AL MIO ORDINE?

Se avete l'impressione che manchi qualche oggetto all'interno del vostro ordine, contattate il nostro amichevole e disponibile servizio di assistenza clienti entro 7 giorni dalla consegna del prodotto.

COME DEVO COMPORTARMI SE I MOBILI INIZIANO A TRABALLARE O A MUOVERSI?

Le viti e i bulloni devono essere controllati regolarmente per verificare la tenuta e la sicurezza dei mobili. Serrare sempre le viti o i bulloni allentati.

**PER QUALSIASI ALTRA PROBLEMATICHE, SI PREGA DI
CONTATTARE
IL NOSTRO SERVIZIO DI ASSISTENZA CLIENTI.**

OMSCHRIJVING

PRODUCT OMSCHRIJVING

Bedankt voor de aankoop van deze Rotan Kubusset, de perfecte tuinmeubelset. Bestaande uit 4 stoelen en 4 krukken, samen met de glazen tafel, biedt deze modieuze set een ruime zithoek, ideaal voor buitenbijeenkomsten en feestjes.

Voor extra gemak en om zoveel mogelijk ruimte te besparen is deze set voorzien van krukjes die perfect onder de stoelen passen. De stoelen kunnen gemakkelijk worden ingeklapt en onder de tafel worden geschoven, waardoor deze set de ideale oplossing is om een opgeruimde buitenruimte te houden.

Met een gratis regenhoes is de Rotan Kubusset beschermd tegen lichte regenbuien, zodat u hem niet naar binnen hoeft te verplaatsen! De set bevat ook UV-stabilisatoren om hem te beschermen tegen de zon.

Raadpleeg en lees de veilige werkmethoden om letsel of schade aan de kubusset te voorkomen voordat u begint.

PRODUCTSPECIFICATIES

STOELEN

AFMETINGEN: MATERIAAL:	53cm (W) x 53cm (L) x 90cm (H)
DRAAGVERMOGEN:	Rotan, Gepoedercoat Staal 140kg
KUSSEN DIKTE:	5cm

TAFEL

AFMETINGEN:	110cm (W) x 110cm (L) x 74cm (H)
MATERIAAL:	Rotan, Gepoedercoat Staal, 5mm Gehard Glas
DRAAGVERMOGEN:	80kgs







KRUKKEN

AFMETINGEN:	53cm (W) x 53cm (L) x 40cm (H)
MATERIAAL:	Rotan, Gepoedercoat Staal
DRAAGVERMOGEN:	120kg
KUSSEN DIKTE:	5cm

De aansprakelijkheid van Monster Group UK Limited is beperkt tot de commerciële waarde van het product.

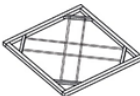
SPECIFICATIE

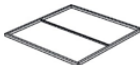
ITEM INHOUD

Part Ref.	Afbeelding	Omschrijving	Aantal
A		Stoel - Linker Paneel	4
B		Stoel - Rechter Paneel	4
C		Stoel - Achter Paneel	4
D		Stoel - Basis Paneel	4
E		Stoel Rug	4
F		Tafel - Bovenblad	1
G		Tafel - Poten	1

De aansprakelijkheid van Monster Group UK Limited is beperkt tot de commerciële waarde van het product.





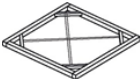
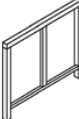
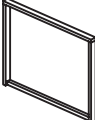
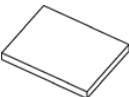
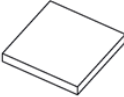
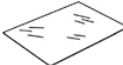

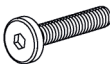

SPECIFICATIE

ITEM INHOUD

Part Ref.	Afbeelding	Omschrijving	Aantal
H		Tafel Bodempaneel	2
I		Kruk - Bovenkant	4
J		Kruk - Poten	8
K		Kruk - Zij Panelen	8
L		Zitkussen	8
M		Krukkussen	4
N		Glass - Table Top	1

SPECIFICATIE

ITEM INHOUD

Part Ref.	Afbeelding	Omschrijving	Aantal
1		Ring	114
2		Bout 6*40	18
3		Bout 6*20	24
4		Bout 6*30	68
5		Dopmoer	4
6		Plastic Ring	8
7		Beugel	8
8		Moersleutel	1
9		Inbussleutel	2

VEILIGHEIDSADVIJES



VEILIGE WERKMETHODEN

Lees de veilige werkmethoden door om letsel of schade aan het apparaat te voorkomen.

- Gebruik dit product niet voor andere doeleinden dan waarvoor het bestemd is.
- Zorg ervoor dat u de instructiehandleiding en het veiligheidsadvies hebt gelezen en volledig begrijpt voordat u dit product gebruikt.
- Wij raden aan dat ten minste twee personen samenwerken voor de montage.
- Breng geen lichaamsgewicht aan op dit product voordat het is geïnstalleerd.
- Houd kleine onderdelen uit de buurt van kinderen.
- Zorg ervoor dat dit product correct is gemonteerd.
- Gebruik dit product op een vlakke ondergrond.
- Stel dit product niet bloot aan vuur.
- Laat dit product niet overmatig heet worden.
- Overschrijd het maximale gewicht van het meubilair niet.

GEBRUIKERSGIDS

MONTAGEHANDLEIDING

Om de montage van uw Rotan meubelen te vergemakkelijken, raden wij u aan de bouten en moeren slechts half aan te draaien wanneer u de meubelen voor het eerst monteert. Zodra u de complete set hebt gemonteerd, kunt u alle bouten en moeren volledig aandraaien.

1

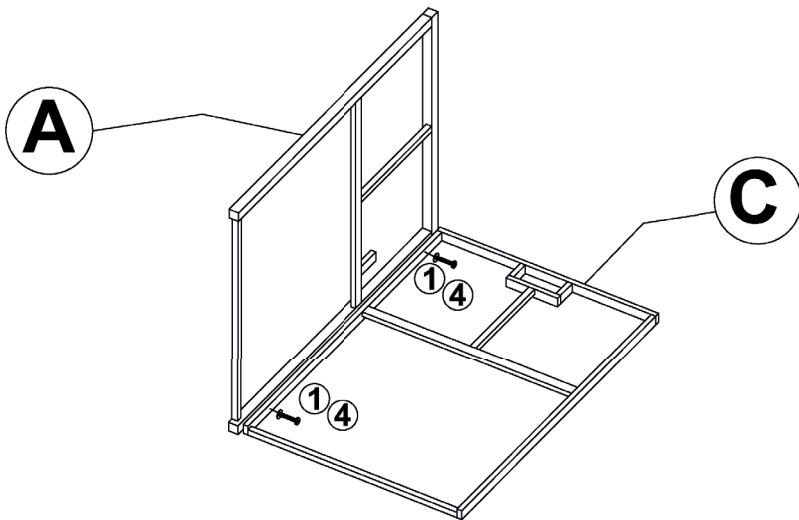

GEBRUIKERSGIDS

MONTAGEHANDLEIDING

2

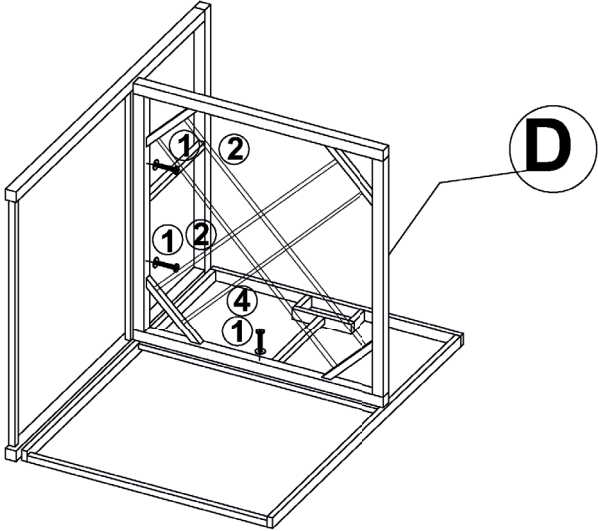

3

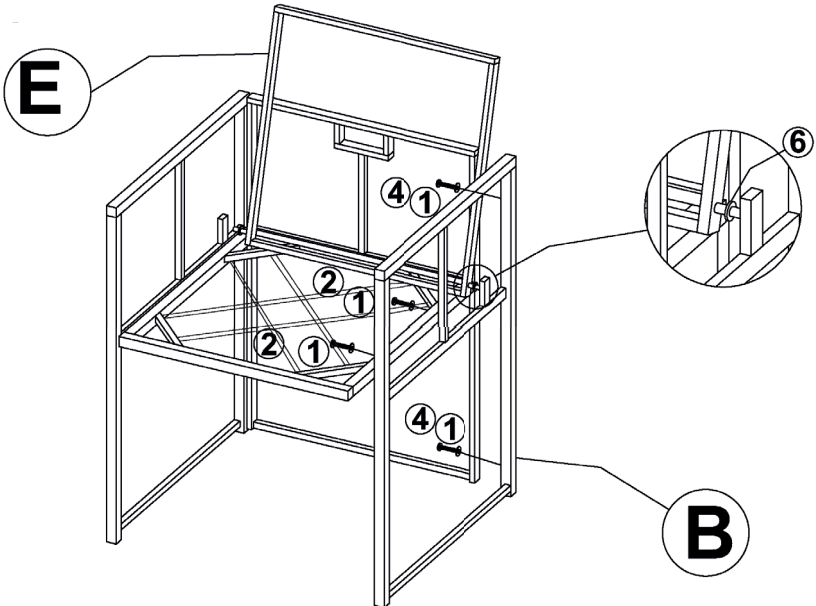

GEBRUIKERSGIDS

MONTAGEHANDLEIDING

4

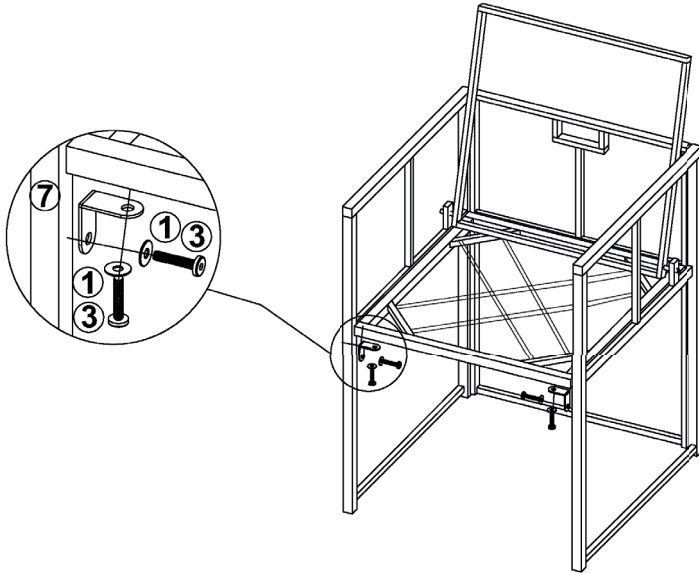

5

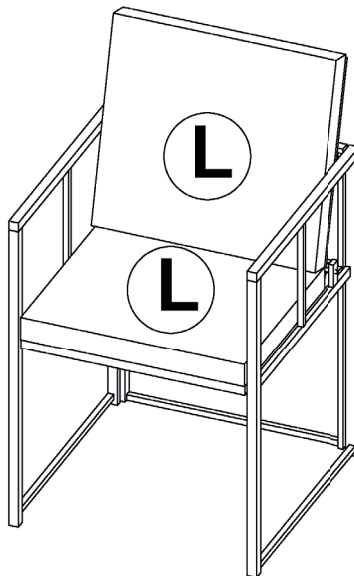

GEBRUIKERSGIDS

MONTAGEHANDLEIDING

6

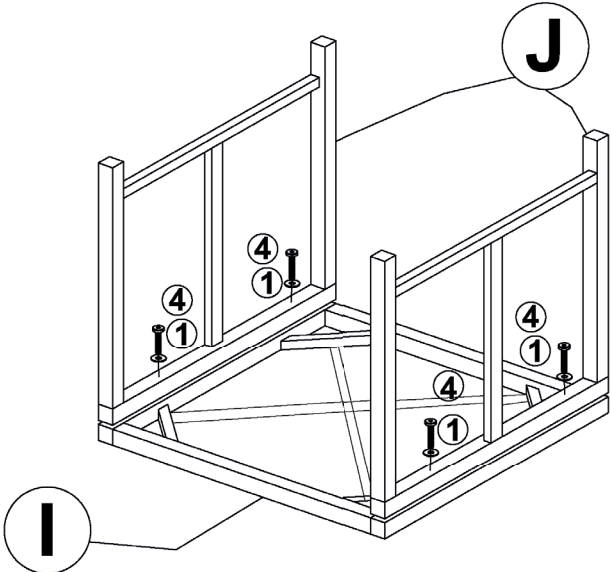

7

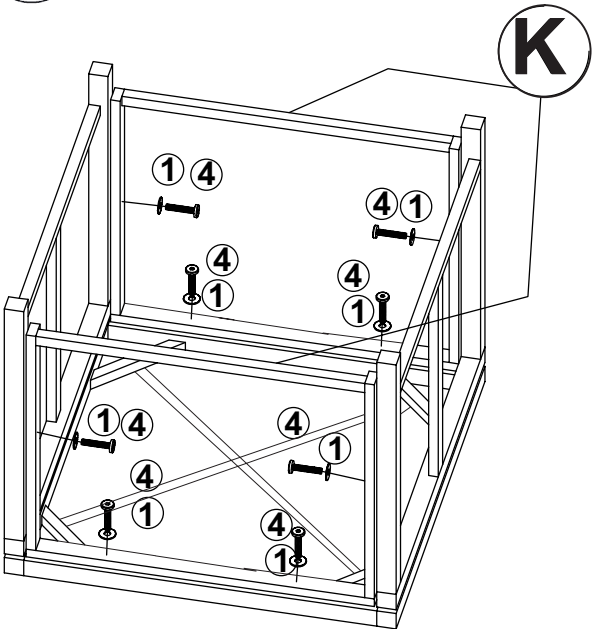

GEBRUIKERSGIDS

MONTAGEHANDLEIDING

8

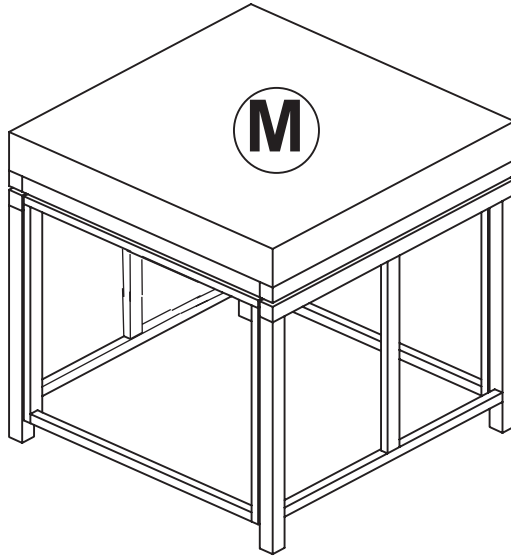

9

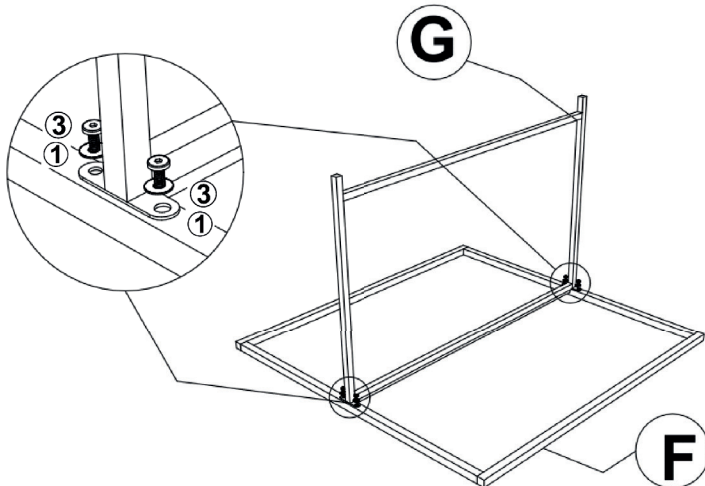

GEBRUIKERSGIDS

MONTAGEHANDLEIDING

10

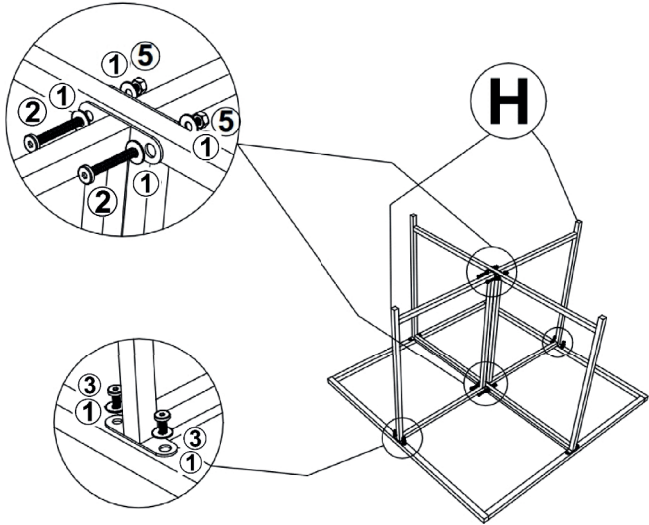

11

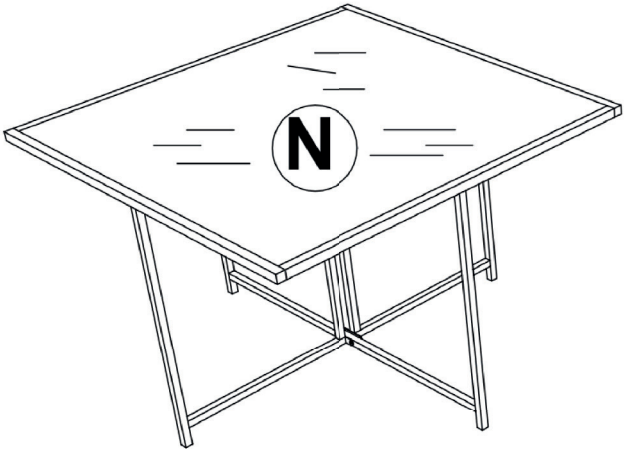

GEBRUIKERSGIDS

MONTAGEHANDLEIDING

12

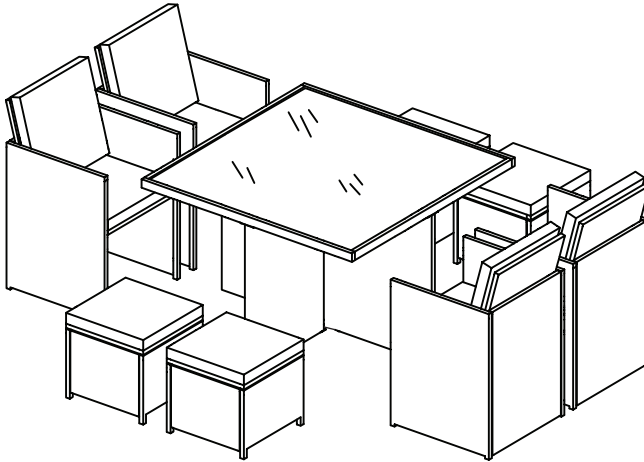

Zorg ervoor dat alle bouten en moeren goed vastzitten voordat u het meubel voor het eerst gebruikt.

GEBRUIKERSGIDS

ONDERHOUD

- Gebruik een zachte doek, warm water en een mild schoonmaakmiddel om de Rotan Kubusset schoon te maken. Om de kussens schoon te maken, neemt u ze af met een vochtige doek. Gebruik een mild schoonmaakmiddel en een zachte doek in geval van hardnekkige vlekken.
- Gebruik de gratis regenhoes om de Rotan Kubusset te beschermen wanneer de set niet in gebruik is. Zorg ervoor dat de set tijdens de winter binnen op een koele, droge plaats wordt opgeslagen, om schimmelvorming op de kussens te voorkomen.
- De schroeven en bouten regelmatig controleren en zo nodig aandraaien.

TROUBLESHOOTING

OPLOSSINGSGIDS

WAT MOET IK DOEN ALS ER ONDERDELEN VAN MIJN BESTELLING ONTBREKEN?

Als er een onderdeel van uw bestelling ontbreekt, neem dan binnen 7 dagen na ontvangst contact op met onze vriendelijke en behulpzame klantenservice.

WAT MOET IK DOEN ALS DE MEUBELS BEGINNEN TE WIEBELEN / BEWEGEN?

De schroeven en bouten moeten regelmatig worden gecontroleerd om er zeker van te zijn dat ze goed vastzitten. Draai alle schroeven of bouten die los zitten weer aan.

VOOR ALLE ANDERE PROBLEMEN KUNT U CONTACT OPNEMEN MET ONZE KLANTENSERVICE.



SPECIFIKATION

PRODUKT BESKRIVNING

Tack för att du köpte detta rottingkubset, det perfekta trädgårdsmöbelsetet. Bestående av 4 stolar och 4 pallar, tillsammans med det glasklädda bordet, ger denna fashionabla uppsättning en rejäl sittgrupp, perfekt för utomhusträffar och fester.

För extra bekvämlighet och för att maximera platsbesparingen har denna uppsättning pallar som passar perfekt under stolarna. Stolarna är byggda för att enkelt kunna fällas ihop och glida under bordet, vilket innebär att detta set är den perfekta lösningen för att hålla ett städat utomhusutrymme.

Med det medföljande regnskyddet är rottingkubsetet skyddat från lätta skurar, därför behöver du inte flytta in det! Setet innehåller också UV-stabilisatorer för att skydda det från solen.

Se och läs Säker arbetspraxis för att säkerställa förebyggande av personskador eller skador på kubuppsättningen innan du börjar.

PRODUKTSPECIFIKATION

STOLAR

MÅTT:	53cm (B) x 53cm (L) x 90cm (H)
MATERIAL:	Rotting, pulverlackerat stål
VIKT KAPACITET:	140kg
KUDDENS TJOCKLEK:	5cm

BORD

MÅTT:	110cm (B) x 110cm (B) x 74cm (H)
MATERIAL:	Rotting, pulverlackerat stål, 5 mm härdat glas
VIKT KAPACITET:	80 kg







AVFÖRING

MÅTT:	53cm (B) x 53cm (L) x 40cm (H)
MATERIAL: VIKT	Rotting, pulverlackerat stål
KAPACITET:	120kg
KUDDENS TJOCKLEK:	5cm

Monster Group UK Limiteds ansvar kommer endast att begränsas till produktens kommersiella värde.

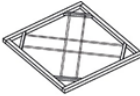
SPECIFIKATION

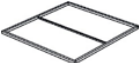

INNEHÅLL

Av Ref.	Bild	Beskrivning:	Kvantitet
A		Stol - Vänster panel	4
B		Stol - Höger panel	4
C		Stol - Bakpanel	4
D		Stol - Baspanel	4
E		Stol rygg	4
F		Bord - övre panelen	1
G		Bord - Ben	1

Monster Group UK Limiteds ansvar begränsas endast till produktens kommersiella värde.

SPECIFIKATION

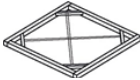
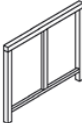
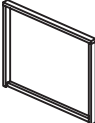
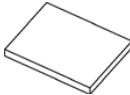
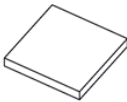
INNEHÅLL

Av Ref.	Bild	Beskrivning	Kvantitet
H		Nedre panelen	2
I		Pall - Topp	4
J		Pall - Ben	8
K		Pall - Sidopaneler	8
L		Sittdyna	8
M		Pall kudde	4
N		Glas - bordsskiva	1

SPECIFIKATION

INNEHÅLL

Av Ref.	Bild	Beskrivning	Kvantitet
1		Bricka	114
2		Bult 6*40	18
3		Bult 6*20	24
4		Bult 6*30	68
5		Mutter	4
6		Plastbricka	8
7		Vinkeljärn	8
8		Skruvnyckel	1
9		Insexnyckel	2

SKYDDSRÅD

SÄKER ARBETSPRAXIS

Läs igenom Säker arbetspraxis för att säkerställa att du förhindrar personskador eller skador på enheten.

- Använd inte denna produkt för något annat än dess avsedda ändamål.
- Se till att du har läst och förstått bruksanvisningen och säkerhetsanvisningarna innan du använder den här produkten.
- Vi rekommenderar att minst två personer arbetar med monteringen tillsammans.
- Lägg inte kroppsvikt på denna produkt innan den installeras .
- Håll små delar borta från barn.
- Se till att denna produkt är korrekt monterad.
- Använd den här produkten på en plan yta.
- Utsätt inte denna produkt för eld.
- Låt inte denna produkt bli alltför varm.
- Överskrid inte möblernas maximala viktkapacitet.

ANVÄNDARE GUIDE

MONTERINGSANVISNINGAR

För att underlätta monteringen av dina rottingmöbler rekommenderar vi att du först bara drar åt muttrarna och bultarna till hälften när du monterar möblerna.

När du har monterat hela uppsättningen kan du sedan dra åt alla muttrar och bultar helt.

1

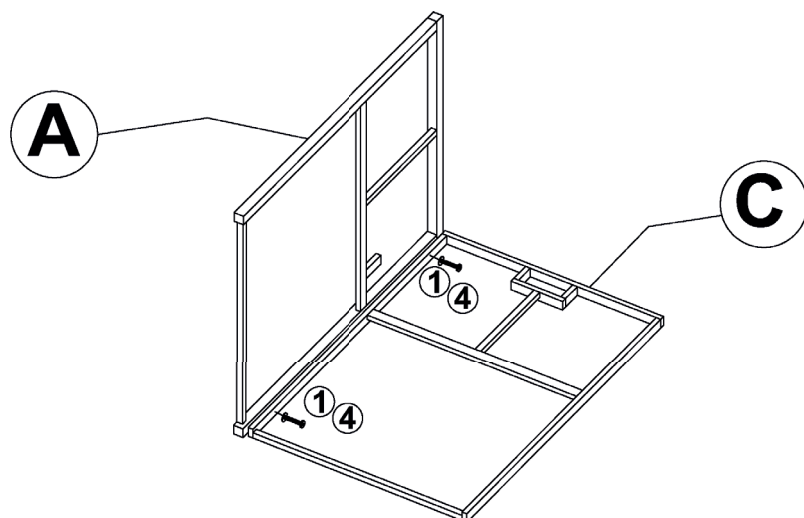

ANVÄNDARE GUIDE

MONTERINGSANVISNINGAR

2

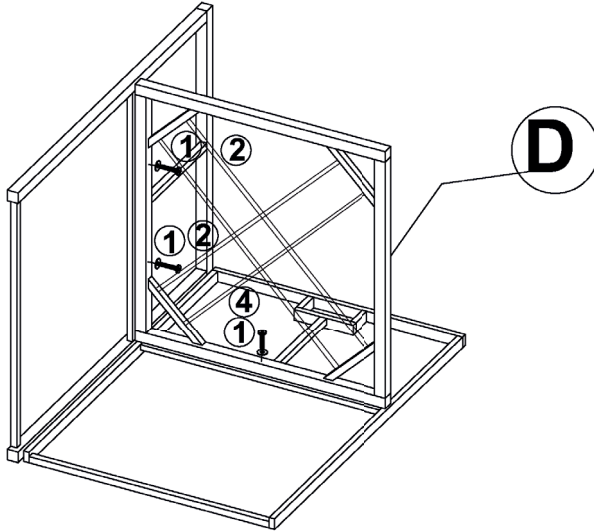

3

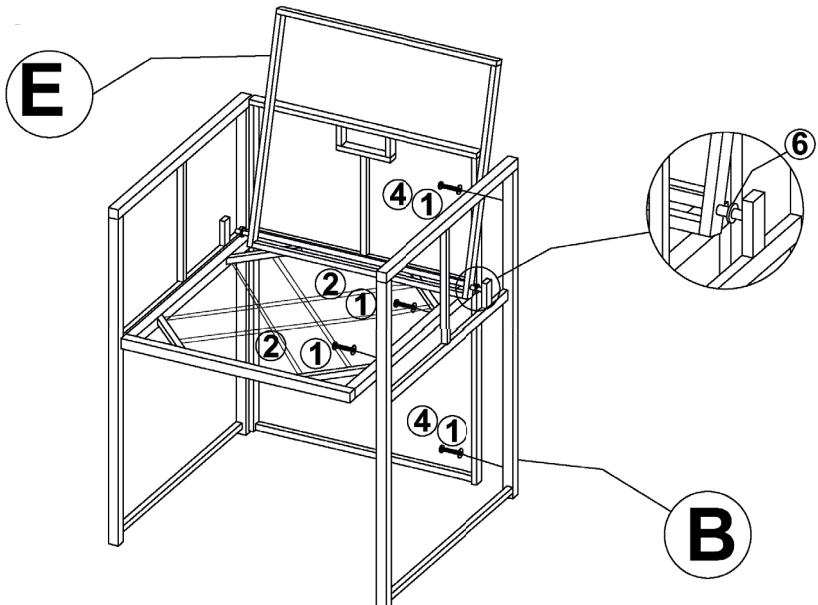

ANVÄNDARE GUIDE

MONTERINGSANVISNINGAR

4

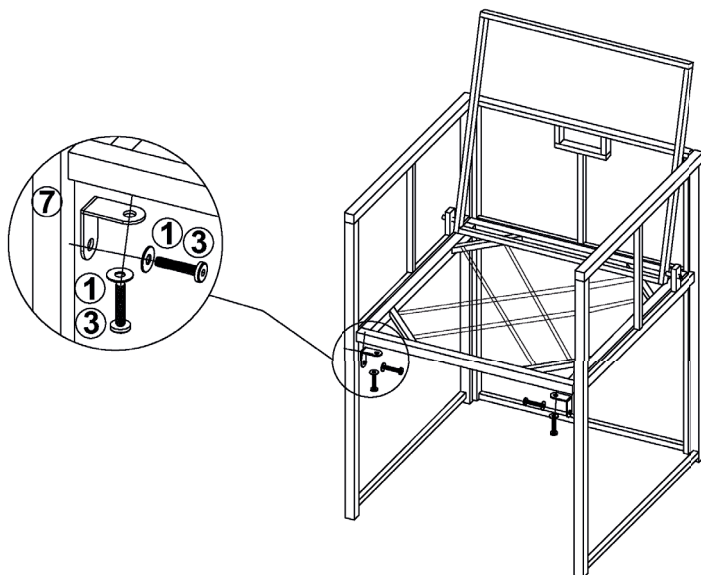

5

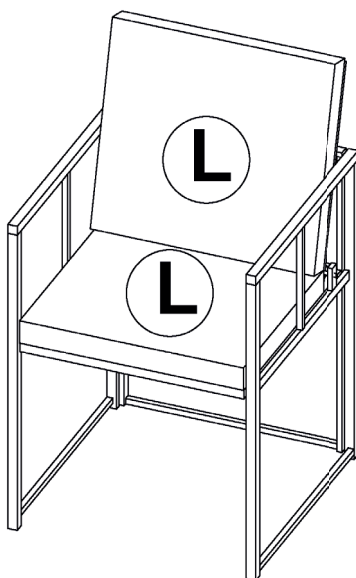

ANVÄNDARE GUIDE

MONTERINGSANVISNINGAR

6

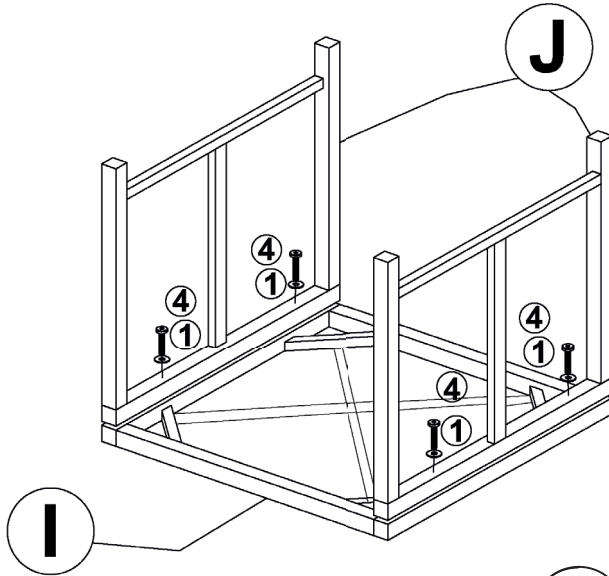

7

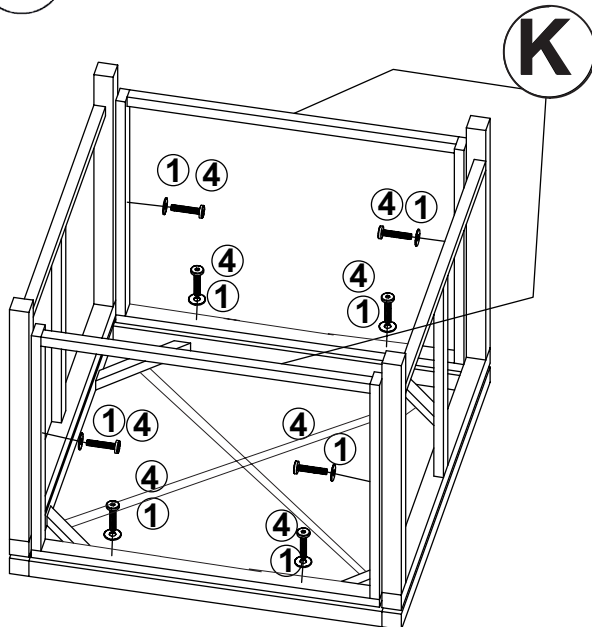

ANVÄNDARE GUIDE

MONTERINGSANVISNINGAR

8

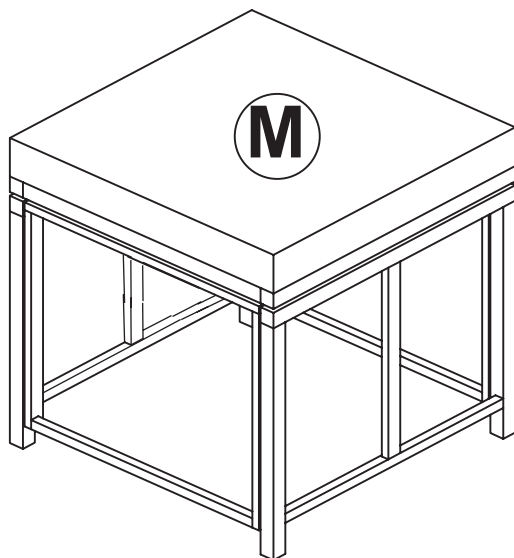

9

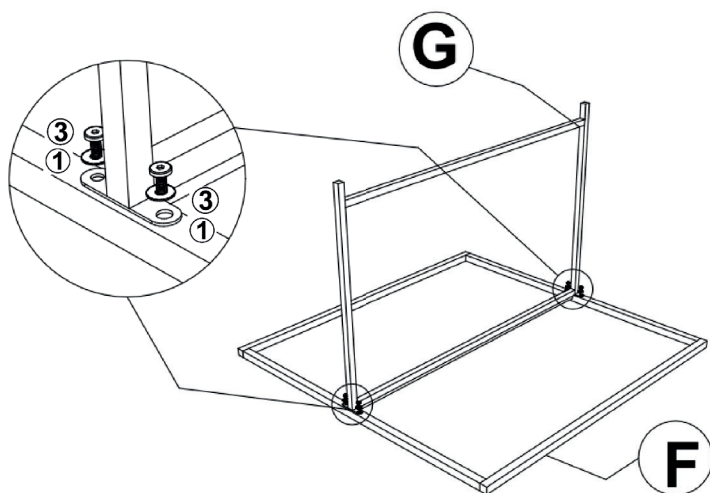

ANVÄNDARE GUIDE

MONTERINGSANVISNINGAR

10

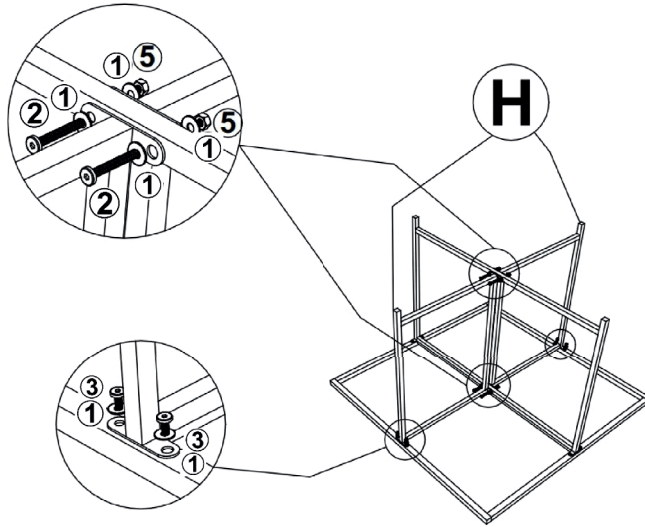

11

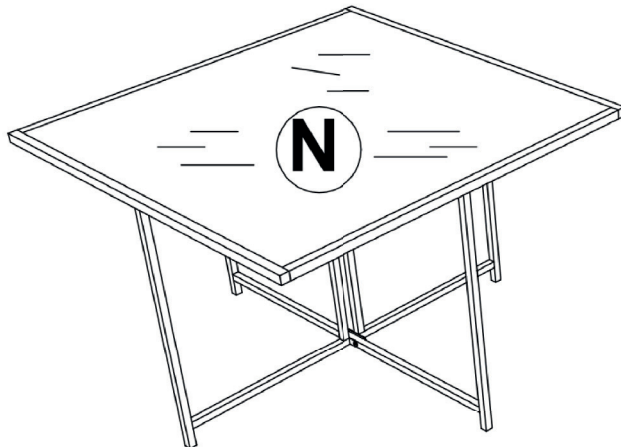

ANVÄNDARE GUIDE

MONTERINGSANVISNINGAR

12

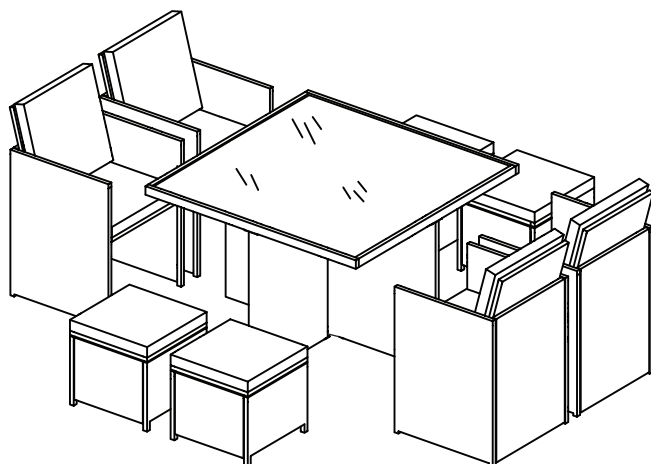

Se till att alla muttrar och bultar är helt åtdragna innan du använder möblerna första gången.e.

ANVÄNDARHANDBOK

UNDERHÅLL

- Använd en mjuk trasa, varmt vatten och mildt tvättmedel för att torka av när du rengör rottingmöblerna. För att rengöra kuddarna: torka av dem med en fuktig trasa. Använd mildt tvättmedel och en mjuk trasa vid envisa fläckar.
- Använd det medföljande regnskyddet för att skydda rottingkuben när setet inte används. Se till att setet förvaras inomhus på en sval, torr plats under vintern för att förhindra mögel och mögeltillväxt på kuddarna.
- Kontrollera skruvarna och bultarna regelbundet och dra åt dem vid behov.

FELSÖKNING

GUIDE FÖR PROBLEMLÖSNING

VAD GÖR JAG OM DET SAKNAS DELAR I MIN BESTÄLLNING?

Om det verkar saknas någon del i din beställning, kontakta vårt vänliga och hjälpsamma kundsupportteam inom 7 dagar efter mottagandet.

VAD GÖR JAG OM MÖBLERNA BÖRJAR VINGLA/RÖRA SIG?

Skruvarna och bultarna måste kontrolleras regelbundet för att säkerställa att de är täta och säkra. Dra åt alla skruvar eller bultar som är lösa.

**FÖR ALLA ANDRA FRÅGOR, VÄNLIGEN KONTAKTA VÅRT
KUNDSUPPORTTEAM.**

Monster Group (UK) is one of the UK's fastest growing online retailers. We supply a diverse range of products which offer exceptional value for money. We strive to provide the best possible customer experience with free UK delivery across all our products and a Monster Guarantee for 100% satisfaction.

For information regarding this device or other products from our Monster divisions please contact Sales.

SALES

TEL: 01347 878 888

EMAIL: hello@monstershop.co.uk

For queries about this device, warranty, returns or reporting faults please contact Support.

SUPPORT

TEL: 01347 878 887

EMAIL: help@monstershop.co.uk

Pour plus d'informations concernant cet appareil ou d'autres produits de nos divisions de Monster veuillez utiliser les détails suivants ci-dessous.

DÉPARTEMENT COMMERCIAL

TEL: 01347 878 888

EMAIL: bonjour@monstershop.eu

Pour les interrogations concernant cet appareil, la garantie, les retours ou les défauts de déclaration veuillez utiliser les détails suivants ci-dessous.

DÉPARTEMENT DE SOUTIEN

TEL: 01347 878 887

EMAIL: help@monstershop.co.uk

Para información sobre este dispositivo u otros productos de nuestras divisiones de Monster por favor use los siguientes detalles.

DEPARTAMENTO DE VENTAS

TEL: 01347 878 888

EMAIL: hola@monstershop.eu

Para consultas sobre este dispositivo, la garantía, devoluciones o denuncias de fallos por favor use los siguientes detalles.

DEPARTAMENTO DE SOPORTE

TEL: 01347 878 887

EMAIL: help@monstershop.co.uk

Für Informationen bezüglich dieses Geräts oder anderer Produkte aus unserer Monster-Abteilung, benutzen sie die folgenden unten aufgeführten Angaben.

VERKAUFABTEILUNG

TEL: 01347 878 888

EMAIL: hallo@monstershop.eu

Für Fragen über dieses Gerät, die Garantie, Rückgaben oder bei Störungen, benutzen sie die folgenden unten aufgeführten Angaben.

SUPPORT-ABTEILUNG

TEL: 01347 878 887

EMAIL: help@monstershop.co.uk

Per informazioni riguardanti questo dispositivo o altri prodotti dalle categorie Monster utilizzare i dettagli sotto riportati.

DIPARTIMENTO VENDITE

TEL: 01347 878 888

EMAIL: ciao@monstershop.eu

Per domande riguardo dispositivo, garanzia, reso o per riferire di guasti, utilizzare i dettagli sotto riportati.

DIPARTIMENTO SUPPORTO

TEL: 01347 878 887

EMAIL: help@monstershop.co.uk

Monster House, Alan Farnaby Way,
Sheriff Hutton Industrial Estate,
Sheriff Hutton, York, YO60 6PG
www.monstershop.co.uk



 Try **Monster**. Buy **Monster**. Be **Monster**. 