

BBQ Smoker Grill XXL

29205

INSTRUCTION MANUAL

www.monstershop.co.uk

SPECIFICATION

PRODUCT DESCRIPTION

This Jardí BBQ Smoker Grill is an ideal addition to any garden – whether you're an occasional BBQ enthusiast or a real grilling master – this is the ultimate tool to add to your cooking entourage. With the 6 height adjustable coal tray, you can be rest assured that you'll be able to satisfy anyone's taste buds.

PRODUCT SPECIFICS



MATERIAL:	Steel
DIMENSIONS:	111cm (H) x 142cm (W) x 62cm (D)
GRILL SIZE:	77cm x 43.5cm
WEIGHT:	34.5KG

PRODUCT FEATURES

- 6 height adjustable coal tray with handle
- 2 x Foldable shelves
- Temperature gauge
- Wire Brush
- Waterproof Cover



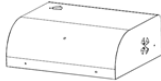









PARTS LIST

When first unpacking your BBQ smoker grill, check each part against this list to ensure that they are all present. If any are missing contact us before attempting to assemble.

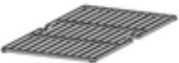
Part No.	Description	Illustration	Quantity
1	Grill Lid		X 1
2	Chimney		X 1

SPECIFICATION

PARTS LIST

3	Vent Handles		X 2
4	Temperature Gauge		X 1
5	Lid Vents		X 2
6	Bottle Opener		X 1
7	Lid Handle		X 1
8	Warming Rack		X 1
9	Cast Iron Cooking Grids		X 3
10	Lift Rack		X 1
11	Hooks		X 4
12	Right Side Shelf		X 1
13	Left Side Shelf		X 1
14	Side Panel Support Bar		X 2

Monster Group UK Limited's liability will be limited to the commercial value of the product only.

















PARTS LIST

15	Air Vents		X2
16	Charcoal Tray		X1
17	Ash Pan		X 1
18	Ash Pan Handle		X 1
19	Upper Hinges		X 2
20	Lower Hinges		X 2
21	Left Upper Bracket		X 1
22	Right Upper Bracket		X 1
23	Crank		X 1
24	Lower Brackets		X 2
25	Lower Arms		X 2
26	Left Side Panel		X 1
27	Rear Panel		X 1
28	Front Panel		X 1

PARTS LIST

29	Right Side Panel		X 1
30	Cast Iron Door		X 1
31	Wheels		X 2
32	Axle		X 1
33	Front Wheel Leg		X 1
34	Rear Wheel Leg		X 1
35	Front Stationery Leg		X 1
36	Rear Stationery Leg		X 1
37	Bottom Panel		X 1
38	Frame Rear Beam		X 1
39	Frame Side Beams		X 2
40	Fire Damper		X 1
41	Height Adjusting Plate		X 1
42	Lever Support Bracket		X 2
A	M6 12mm Screw		X 59

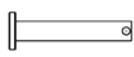
PARTS LIST

B	M6 20mm Screw		X 4
C	M6 35mm Screw		X 8
D	M6 18mm Screw		X 8
E	M5 12mm Screw		X 20
F	M4 10mm Screw		X 4
G	M6 Flange Nut		X 27
H	M5 Flange Nut		X 10
I	M8 Lock Nut		X 2
J	M4 Flat Gasket		X 2
K	M6 Flat Gasket		X 5
L	M8 Flat Gasket		X 2
M	Cotter Pin		X 16
N	M5 8mm Hinge Pin		X 7
O	M5 25mm Hinge Pin		X 3
P	M5 35mm Hinge Pin		X 2
Q	M5 45mm Hinge Pin		X 2

SAFETY ADVICE

SAFE WORKING PRACTICE

Please read through the Safe Working Practice to ensure prevention of injury or damage to the device.

- Ensure you have read and fully understood the instruction manual and safety advice before assembling this product.
- Ensure that the grill is handled and assembled according to these instructions.
- Do not use this product for anything other than its intended purposes.

GRILL PLACEMENT SAFETY

- Always use the grill outdoors.
- NEVER use the grill in an enclosed space or under a covered area. Charcoal creates carbon monoxide and therefore should always be burned in a well-ventilated area.
- DO NOT use this grill within 10'(3m) of any combustible material, including, but not limited to shrubbery, trees, wood or treated wood decks, fences, patios, porches, walls, vehicles, gasoline, lighter fluid, or any other flammable liquid.
- ONLY use this grill on a hard, level, non-combustible, stable surface, such as concrete that can support the weight of the grill. NEVER use on wood or other combustible surfaces.
- NEVER use this grill where children or pets could come into contact with the grill.

GRILL PREPARATION SAFETY

- We recommend using charcoal as this will not exceed the maximum combustible temperature for the grill. We recommend only using wood chips for flavouring; please be aware that it can be difficult to control the temperature and damage may occur to the grill.
- We recommend that you use 2-4kg. of charcoal at a time, as this will help to ensure you can control the temperature.
- The optimal grilling time is 4 - 6 hours.
- Do NOT use the grill without the ash tray in place.
- Do NOT use this grill unless fully assembled and all parts are in working order.

SAFETY ADVICE

SAFE WORKING PRACTICE

CHARCOAL LIGHTING SAFETY

- We recommend a charcoal chimney starter to avoid the dangers of charcoal starter fluid. ALWAYS read and follow the chimney starter manufacturer's instructions and warnings. Failure to do so could result in serious injury.
- If you use charcoal starter fluid, ONLY use starter fluid approved for lighting charcoal
- NEVER use gasoline, alcohol, kerosene, or any other highly flammable liquid. Use of any of these or similar products could cause an explosion, possibly leading to severe bodily injury.
- ALWAYS clean up any starter fluid spills before lighting charcoal.
- ALWAYS allow charcoal starter fluid to completely burn off prior to closing the grill lid. Failure to do so could trap fumes in the grill and might result in flash fire or explosion when the lid is opened.
- NEVER add charcoal starter fluid to hot or warm coals. Flare-ups could occur and cause burns.
- ALWAYS store charcoal starter fluid safely away from grill. DO NOT store starter fluid or other flammable liquids or materials under the grill.
- DO NOT use the grill in windy conditions.

GRILL USE SAFETY

- NEVER leave a hot grill unattended.
- Grill is hot when in use. To avoid burns:
 - DO NOT attempt to move the grill while lit or still hot.
 - ALWAYS wear protective gloves or oven mitts.
 - DO NOT TOUCH any hot grill surfaces.
- DO NOT wear loose clothing or allow hair to come into contact with grill.
- NEVER add pre-soaked charcoal to hot or warm coals or ashes. Dangerous or explosive flare-ups could occur and result in bodily harm.
- USE EXTREME CAUTION when adding charcoal and/or wood to the grill while cooking, as charcoal is still hot and can cause burns.

SAFETY ADVICE

SAFE WORKING PRACTICE

- ALWAYS open lid completely and secure to prevent unexpected closing.
- NEVER place more than 8 lb (3.6kg) on any of the shelves. DO NOT lean on any shelf.
- NEVER add water when smoking as hot water may splash onto the coals creating a burst of steam and hot ash.
- When grilling, grease from food may drip onto the charcoal and cause a grease fire. If this happens close the lid and air vents to suffocate the flame. NEVER use water to extinguish a grease fire.
- Keep hands, face, and body a safe distance from the grill when opening the lid. Flare-ups may occur when flames or hot coals encounter increased airflow.
- NEVER try to remove the ash tray while coals are hot. Doing so could cause burns.
- ALWAYS allow grill and components to cool completely before handling.

AFTER USE SAFETY

- Ensure the grill has fully cooled before covering with the cover provided.
- DO NOT remove ashes or used coals from the grill until they are fully extinguished.
- To extinguish charcoal, close all vents and close the grill lid for as long as possible. When they must be removed, carefully place in a non-combustible metal container. Saturate coals and ash with water and allow them to remain in the metal container for 24 hours before disposing.
- Keep extinguished coals and ash safely away from combustible structures and materials.
- Spray or douse the surfaces under and around the grill with water until completely wet to extinguish any ashes, coals, or embers that may have fallen during grilling or cleaning.
- Store the grill in a dry location out of reach of children and pets when not in use.

USER GUIDE

ASSEMBLY INSTRUCTIONS

1. Check you have each part that is needed to assemble the BBQ smoker grill.
2. Start by attaching the front stationary leg (35), rear stationary leg (36) and wheel legs (33) (34) to the bottom panel (37) using 8x M6 12mm screws (A). Now insert the axle (31) through the holes on the wheel legs (33) (34). Next, place the wheels (31) on the end of each axle and secure with the M8 flat gasket (L) and M8 lock nuts (I).

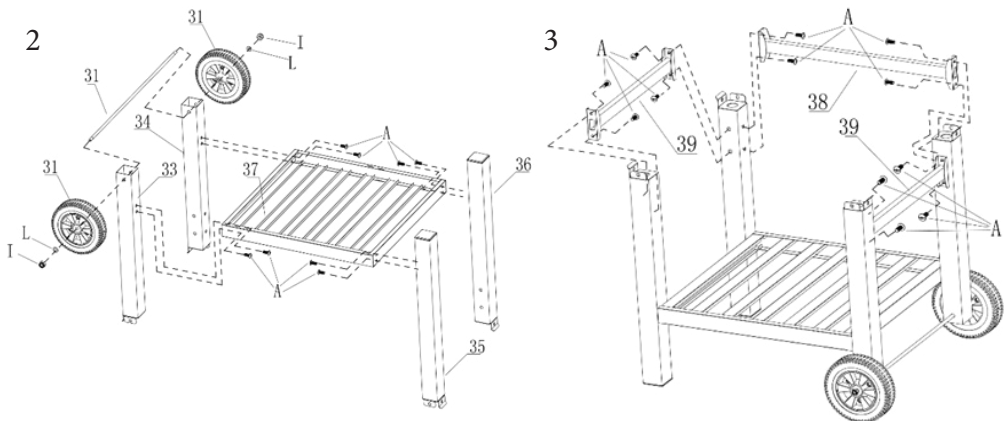

3. Now turn the frame around so the wheels and feet are on the ground. Next attach the frame side beams (39) and frame rear beam (38) to the inside of the legs using 12x M6 12mm screws (A).
4. Now connect the left side panel (26), rear panel (27), front panel (28) and right side panel (29) together using 12x M6 12mm screws (A).

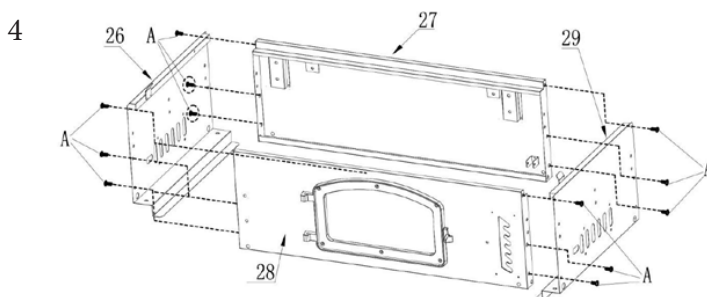

USER GUIDE

ASSEMBLY INSTRUCTIONS

5. Next attach the furnace body you have just assembled to the legs of the base assembled in step 3 using 8x M6 12mm screws (A).

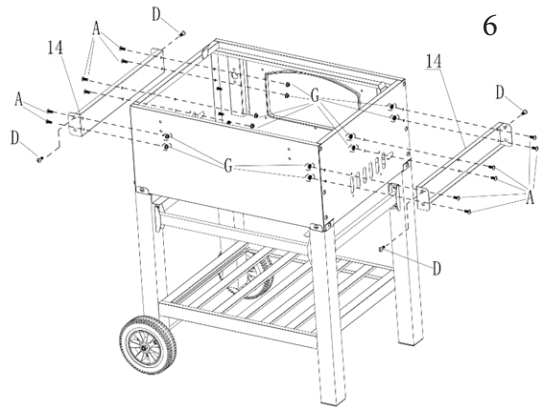
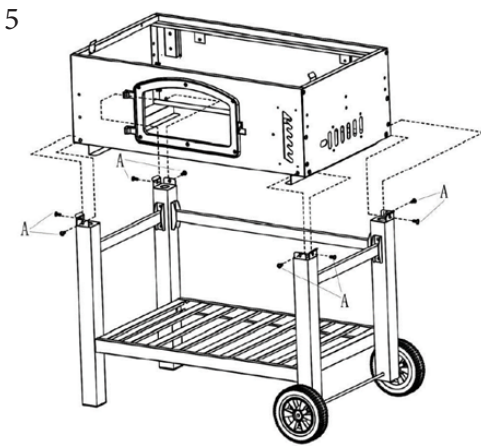

6. Take the two side panel support bars (14) to the two side panels and attach using 12x M6 12mm screws (A), then secure them with 12x M6 flange nuts (G). Pre-install the 4x M6 18mm screws (D) to the side panel support bars (14).

7. Now attach the air vents (15) to the two side panels using 8x M5 12mm screws (E) and secure with 8x M5 flange nuts (H). Secure the vent handles (3) to the air vents (15) with the M4 flat gaskets (J) and M4X10 screw (F).

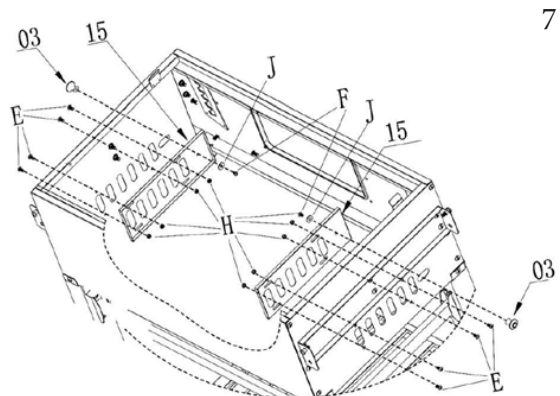

USER GUIDE

ASSEMBLY INSTRUCTIONS

8. Attach the lower brackets (24) to the charcoal tray (15) with 4x M6 12mm screws (A) and secure them with 4x M6 flange nuts (G).

9. Connect the right upper bracket (22) and left upper bracket (21) to the inside of the lower arms (25) using 2x M5 8mm hinge pins (N) and secure both of them with a cotter pin (M).

10. Next attach both lower arms to the outside of the lower brackets (24) using 2x M5 8mm hinge pins (N) and secure each of them with a cotter pin (M).

11. Secure the lift rack (10) to the lower brackets (24) using 2x M5 8mm hinge pin (N) and secure them both with a cotter pin (M).

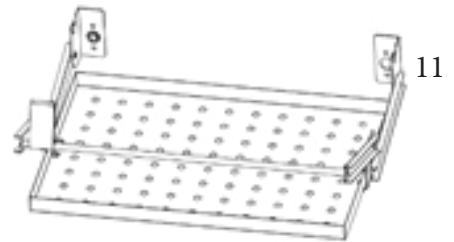
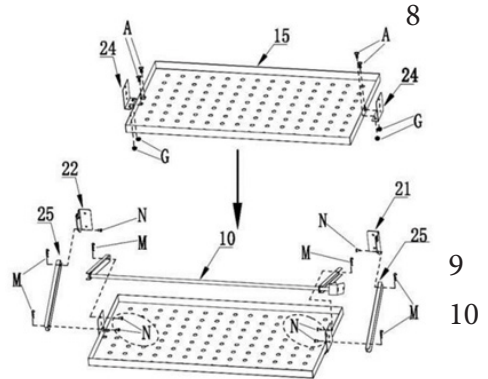

12. Insert the lever (23) through the front panel on the right hand side, and then pass it through both the fire damper (40) and the high adjusting plate (41). Then secure it to the rear panel with a M5 x 25mm hinge pin (P) and cotter pin (M). Now secure the high adjusting plate (41) to the lever with a M5 25mm hinge pin (P) and cotter pin (M). Finally, attach the M5 8mm hinge pin (N) to the fire damper slice and M6 flat gasket, and secure them with a cotter pin (M).

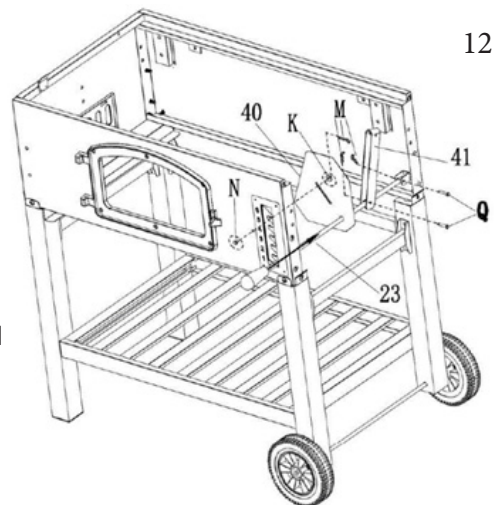

USER GUIDE

ASSEMBLY INSTRUCTIONS

13. Secure the right and left upper bracket to the front panel using 4x M5 12mm screws (E). Then drop the lift rack (10) into the grooves of the left and right upper brackets (21,22)

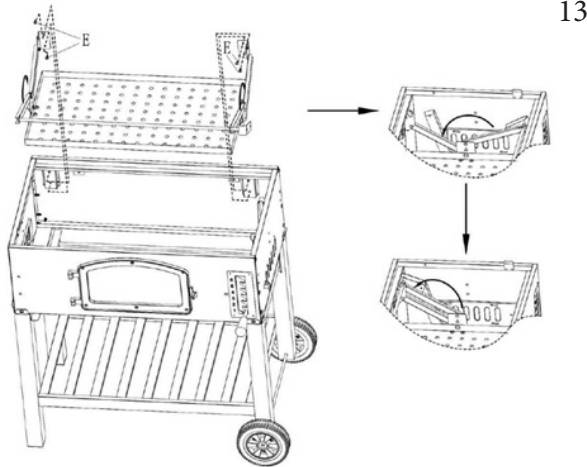

14. Secure the lever support bracket (42) to the left and right upper brackets with 2x M4 10mm screws (F). Now secure the high adjusting plate (10) to the lift rack with M5 25mm hinge pin (P) and a cotter pin (M).

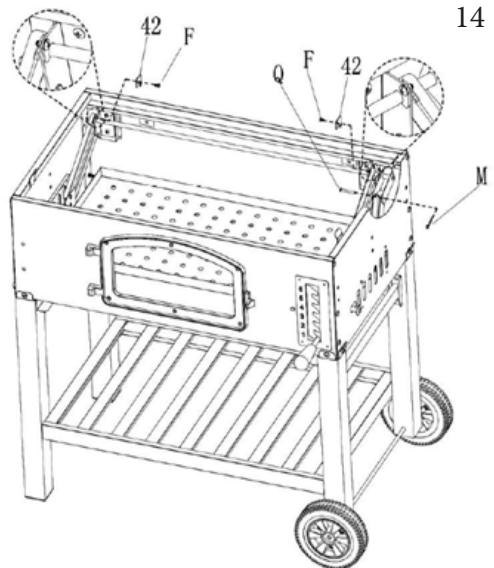

15. Now attach the bottle opener (6) to the front panel using 2x M5 12mm screws (E).

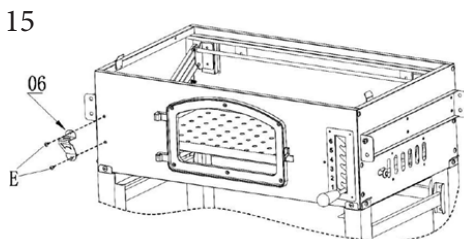

USER GUIDE

ASSEMBLY INSTRUCTIONS

16. Attach the cast iron door (30) to the front panel by 2x M5 45mm hinge pins (O) and secure them with cotter pins (M). secure them with 4x M6 flange nuts (G).

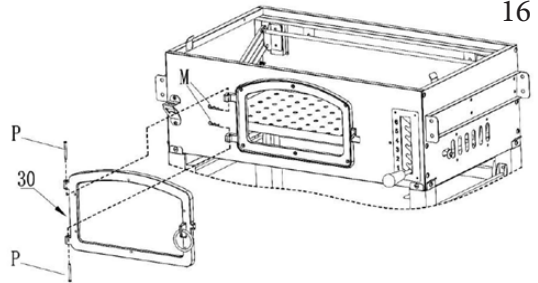

17. Now drop the left side shelf (12) and right side shelf (13) onto the pre-installed screws (D) from step 6. Secure both side shelves to the side panels with 4x M6 18mm screws (D). Attach the lower hinges (20) to the rear panel using 4x M6 35mm screws (C) and secure them with 4x M6 flange nuts (G).

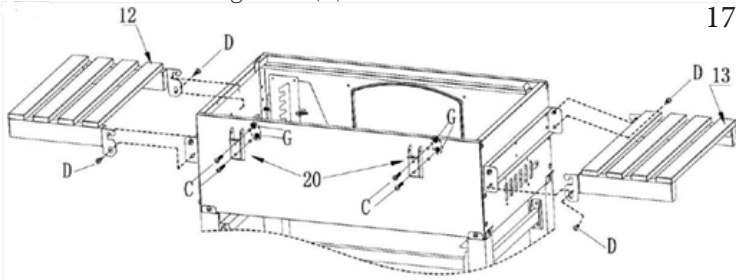

18. Attach the ash handle (18) and the ash handle flange to the ash pan (17) by using 2x M6 flat gaskets (K) and 2x M6 20mm screws (B). shelf with 4x M5 12mm screws (E).

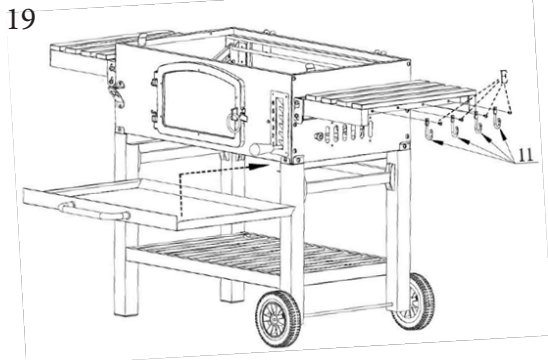
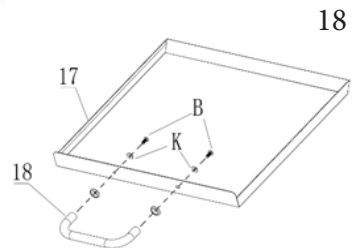

19. Slide the ash pan into the front of the grill, directly under the front panel. Then secure the side hooks (11) to right side shelf with 4x M5 12mm screws (E).

USER GUIDE

ASSEMBLY INSTRUCTIONS

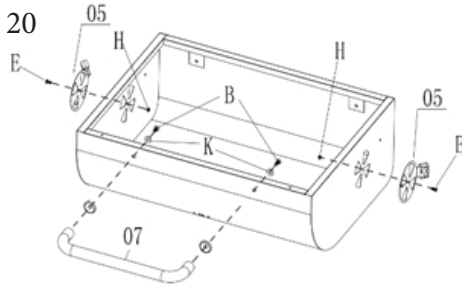

20. To assemble the lid, attach the lid handle (7) and the lid handle flange to the grill lid (1) by using 2x M6 flat gaskets (K) and 2x M6 20mm screws (B). Secure the lid vents (5) to either side of the lid with 2x M5 12mm screws (E) and 2x M5 flange nuts (H).

21. Secure the upper hinges (19) to the grill lid using 4x M6 35mm screws (C) and 4x M6 flange nuts (G).

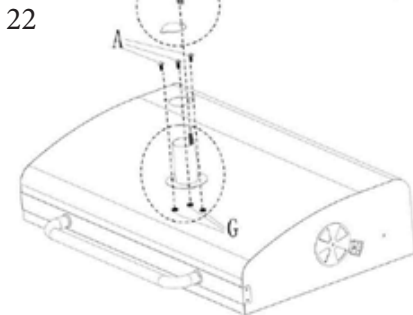
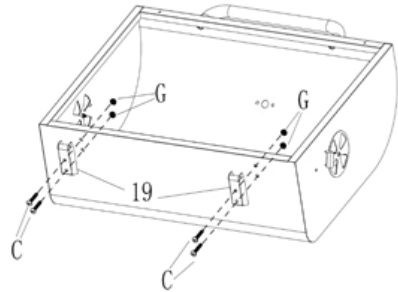

22. Now you will attach the chimney to the lid. First take the chimney lid away, then slide the chimney (2) into the grill lid from the inside. Now secure them with 3x M6 12mm screws (A) and 3x M6 flange nuts (G). Secure the chimney lid back onto the chimney with the provided spring and chimney nut.

23. Next place the temperature gauge (4) through the hole on the grill lid and secure with the provided hardware.

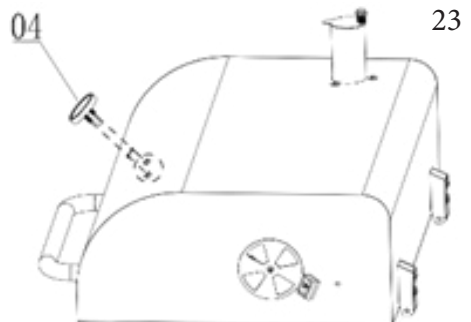

24. Place the grill lid on top of the body of the grill, the upper hinges should fit inside of the lower hinges. Connect the hinges together using 2x M5 35mm hinge pins (Q) and cotter pins (M).

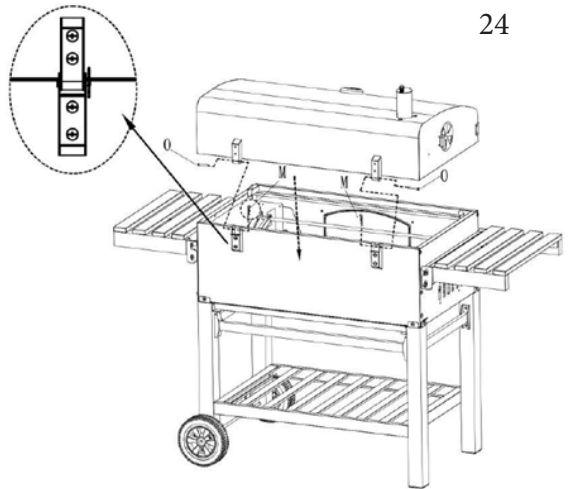

24

25. Snap the left and right sides of the warming rack (8) into the rack holders inside the grill lid and secure it with cotter pins (M). Place the cast iron cooking grids (9) onto the top ledge of the grill body. You should now have your fully assembled BBQ Smoker Grill!

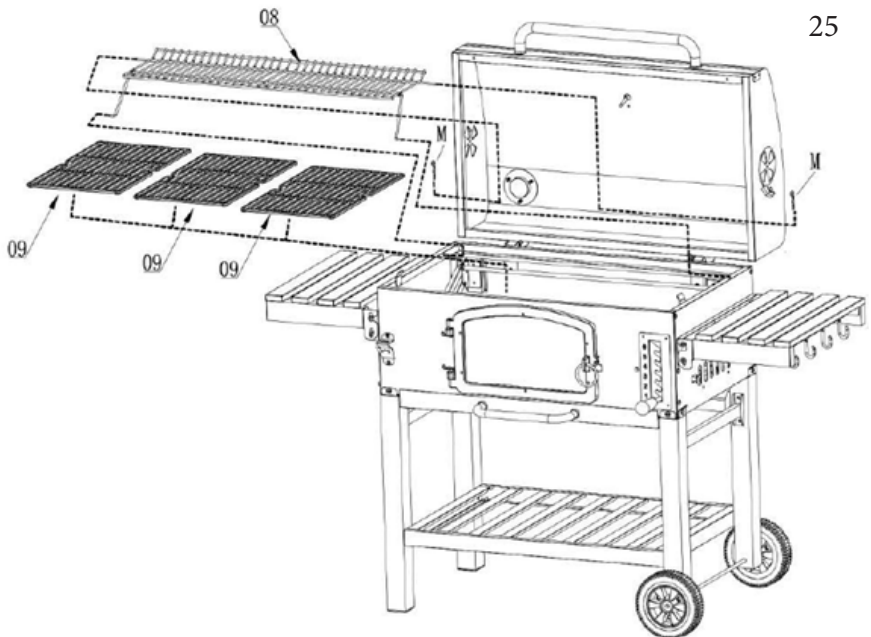

25

TROUBLESHOOTING

RESOLUTION GUIDE

WHAT DO I DO IF THERE ARE MISSING PARTS FROM MY ORDER?

If there appears to be any part missing from your order, contact our friendly and helpful Customer Support Team within 7 days of receipt.

HOW DO I CLEAN MY BBQ SMOKER GRILL?

We recommend that you clean the inside of your grill as soon as it is safe to do so with a combination of hot soapy water and your complimentary wire brush. For the frame, use only a soft cloth and hot soapy water. Make sure to dry it off thoroughly before covering with the cover provided.

WHY IS THE GRILL SURFACE PEELING?

The maximum combustible temperature of the grill is 350°C. If this temperature is exceeded than damage may occur to the grill. We recommend the use of charcoal as fuel because charcoal will only burn to a maximum temperature of 300°C.

**FOR ALL OTHER ISSUES, PLEASE CONTACT OUR
CUSTOMER SUPPORT TEAM.**

SPÉCIFICATIONS

DESCRIPTION DU PRODUIT

Ce barbecue fumoir grilloir Jardi sera parfait pour votre jardin - que vous soyez un amateur du barbecue ou un vrai maître du grill – il est l'élément indispensable à votre équipement de cuisine. Grâce à son bac à charbon à 4 hauteurs réglables, vous serez en mesure de satisfaire les papilles gustatives de tous.

CARACTÉRISTIQUES DU PRODUIT



MATÉRIEL :	Acier
DIMENSIONS :	113.5cm (H) x 124cm (l) x 66cm (P)
TAILLE DU GRILLOIR :	59cm x 43.5cm
POIDS :	29KG

DÉTAILS DU PRODUIT

- Bac à charbon à 4 hauteurs réglables avec poignée
- 2 x étagères pliables
- Jauge de température
- Brosse métallique
- Housse imperméable



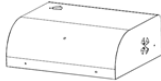







LISTE DES PIÈCES

Lors du déballage de votre barbecue fumoir grilloir, veuillez vérifier chaque pièce par rapport à cette liste afin de vous assurer qu'elles soient toutes présentes. Si des pièces sont manquantes, veuillez nous contacter avant d'essayer assembler le barbecue.

Part No.	Description	Illustration	Quantité
1	Couvercle du grilloir		X 1
2	Cheminée		X 1

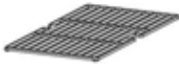



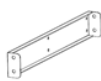

SPÉCIFICATIONS

CARACTÉRISTIQUES DU PRODUIT

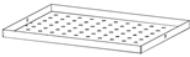





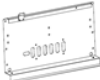
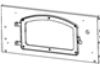







3	Poignée pour évent		X 2
4	Jauge de température		X 1
5	Couvercle pour Évén		X 2
6	Décapsuleur		X 1
7	Poignée du couvercle		X 1
8	Grille de réchaud		X 1
9	Grille de cuisson en fonte		X 3
10	Crémaillère		X 1
11	Crochet		X 4
12	Tablette latérale droite		X 1
13	Tablette latérale gauche		X 1
14	Barre de support de panneau latérale		X 2

La responsabilité de Monster Group UK Limited sera limitée à la valeur commerciale du produit.

LISTE DES PIÈCES

15	Évent		X2
16	Bac à charbons		X1
17	Bac à cendres		X 1
18	Poignée du bac à cendres		X 1
19	Charnières supérieures		X 2
20	Charnières inférieures		X 2
21	Support supérieur gauche		X 1
22	Support supérieur droit		X 1
23	Levier		X 1
24	Support inférieur		X 2
25	Bras inférieur		X 2
26	Panneau latéral gauche		X 1
27	Panneau arrière		X 1
28	Panneau avant		X 1

LISTE DES PIÈCES

29	Panneau latéral droit		X 1
30	Porte en fonte		X 1
31	Roues		X 2
32	Essieu		X 1
33	Support de roue avant		X 1
34	Support de roue arrière		X 1
35	Support fixe avant		X 1
36	Support fixe arrière		X 1
37	Panneau inférieur		X 1
38	Support cadre arrière		X 1
39	Support cadre latéral		X 2
40	Clapet coupe-feu		X 1
41	Plaque de réglage de la hauteur		X 1
42	Support de levier		X 2
A	Vis M6 12mm		X 59

LISTE DES PIÈCES

B	Vis M6 20mm		X 4
C	Vis M6 35mm		X 8
D	Vis M6 18mm		X 8
E	Vis M5 12mm		X 20
F	Vis M4 10mm		X 4
G	Écrou à bride M6		X 27
H	Écrou à bride M5		X 10
I	Contre-écrou M8		X 2
J	Joint plat M4		X 2
K	Joint plat M6		X 5
L	Joint plat M8		X 2
M	Goupille		X 16
N	Axe de charnière M5 8mm		X 7
O	Axe de charnière M5 25mm		X 3
P	Axe de charnière M5 35mm		X 2
Q	Axe de charnière M5 45mm		X 2

CONSEILS DE SÉCURITÉ

PRATIQUE DE TRAVAIL SÉCURITAIRE

Veuillez lire les pratiques de travail sécuritaire afin d'éviter toutes blessures ou dommages sur le barbecue.

- Assurez-vous d'avoir bien lu et compris le manuel d'utilisation et les conseils de sécurité avant d'assembler ce produit.
- Assurez-vous que le grilloir soit manipulé et assemblé conformément à ces instructions.
- N'utilisez pas ce produit à d'autres fins que celles auxquelles il est destiné.

PRÉCAUTIONS D'INSTALLATION DU GRILLOIR

- Utilisez toujours le grilloir à l'extérieur.
- N'utilisez JAMAIS le grilloir dans un espace clos ou dans un endroit couvert. Le charbon de bois dégage du monoxyde de carbone et doit donc toujours être exposé dans un endroit bien ventilé.
- N'utilisez PAS ce grilloir à moins de 3 m (10 pi) de tout matériau combustible, y compris, mais sans s'y limiter, les arbustes, les arbres, les terrasses en bois ou en bois traité, les clôtures, les patios, les porches, les murs, les véhicules, l'essence, l'essence à briquet ou tout autre liquide inflammable.
- Utilisez UNIQUEMENT ce grilloir sur une surface dure, plane, non combustible et stable, telle que du béton pouvant supporter le poids du grilloir. NE JAMAIS utiliser sur du bois ou d'autres surfaces combustibles.
- N'utilisez JAMAIS ce grilloir là où des enfants ou des animaux pourraient entrer en contact avec celui-ci.

PRÉCAUTIONS DE PRÉPARATION DU GRILLOIR

- N'utilisez PAS le grilloir sans le bac à cendres.
- N'utilisez PAS ce grilloir non assemblé entièrement et assurez-vous que toutes les pièces soient en bon état de fonctionnement.

CONSEILS DE SÉCURITÉ

PRATIQUE DE TRAVAIL SÉCURITAIRE

COMMENT ALLUMER LE CHARBON

- Nous vous recommandons d'utiliser une cheminée d'allumage afin d'éviter les dangers liés au liquide d'allumage du charbon. Veuillez TOUJOURS lire les instructions et les conseils de sécurité du fabricant de la cheminée d'allumage. Le non-respect de ces consignes risque d'entraîner des blessures graves.
- Si vous utilisez de l'allume-feu liquide pour charbon de bois, utilisez UNIQUEMENT un liquide approuvé pour charbon de bois
- N'utilisez JAMAIS d'essence, d'alcool, de kérosène ou tout autre liquide hautement inflammable. L'utilisation de l'un de ces produits ou de produits similaires pourrait provoquer une explosion pouvant entraîner des blessures graves.
- Veillez à TOUJOURS nettoyer tout déversement d'allume-feu liquide avant d'allumer le charbon de bois.
- Veillez à TOUJOURS laisser l'allume-feu brûler complètement avant de refermer le couvercle du grilloir. Le non-respect de cette consigne pourrait emprisonner les vapeurs dans le grilloir et provoquer un incendie instantané ou une explosion lorsque le couvercle sera ouvert.
- N'ajoutez JAMAIS d'allume-feu à des charbons ardents ou tièdes. Des flambées pourraient se produire et provoquer des brûlures.
- Veuillez TOUJOURS conserver l'allume-feu à l'écart du grilloir. Veuillez NE PAS stocker d'allume-feu ou d'autres liquides ou matériaux inflammables sous le grilloir.

PRÉCAUTIONS D'UTILISATION DU GRILLOIR

- N'utilisez PAS le grilloir par temps venteux.
- NE JAMAIS laisser un grilloir chaud sans surveillance.
- Le grilloir sera chaud lors de son utilisation. Pour éviter les brûlures :
 - N'essayez PAS de déplacer le grilloir lorsqu'il est allumé ou encore chaud.
 - Veuillez TOUJOURS porter des gants de protection ou des gants de cuisine.
 - NE TOUCHEZ PAS aux surfaces chaudes du grilloir.
- NE portez PAS de vêtements amples et ne laissez pas vos cheveux entrer en contact avec le grilloir.

CONSEILS DE SÉCURITÉ

PRATIQUE DE TRAVAIL SÉCURITAIRE

- N'ajoutez JAMAIS de charbon de bois pré-trempé à des charbons ou des cendres chauds ou tièdes. Des flambées dangereuses ou explosives pourraient se produire et entraîner des blessures.
- SOYEZ EXTRÊMEMENT PRUDENT lorsque vous ajoutez du charbon de bois et/ou du bois sous le grilloir pendant la cuisson, car le charbon de bois sera encore chaud et pourrait causer des brûlures.
- Veuillez TOUJOURS ouvrir le couvercle entièrement et le sécuriser pour éviter une fermeture inattendue.
- NE placez JAMAIS plus de 8 lb (3,6 kg) sur l'une des étagères. NE vous appuyez pas les étagères.
- N'ajoutez JAMAIS d'eau lors du fumage car de l'eau chaude pourrait éclabousser les charbons et créer un jet de vapeur et de cendres chaudes.
- Lors de la cuisson, la graisse des aliments peut s'égoutter sur le charbon de bois et provoquer un feu de graisse. Si cela se produit, fermez le couvercle et les événements d'aération pour étouffer la flamme. N'utilisez JAMAIS d'eau pour éteindre un feu de graisse.
- Gardez les mains, le visage et le corps à une distance sécuritaire du grilloir lors de l'ouverture du couvercle. Des flambées peuvent se produire lorsque des flammes ou des charbons ardents entrent en contact avec un débit d'air accru.
- N'essayez JAMAIS de retirer le bac lorsque les charbons sont chauds. Ceci pourrait entraîner des brûlures.

PROCÉDURES DE SÉCURITÉ APRÈS UTILISATION

- Veuillez TOUJOURS laisser le grilloir et ses composants refroidir complètement avant de les manipuler.
- Assurez-vous que le grilloir soit complètement refroidi avant de le couvrir avec la housse fournie.
- NE retirez PAS les cendres ou les débris de charbons du grilloir avant qu'ils ne soient complètement éteints.

CONSEILS DE SÉCURITÉ

PRATIQUE DE TRAVAIL SÉCURITAIRE

PROCÉDURES DE SÉCURITÉ APRÈS UTILISATION

- Pour éteindre le charbon de bois, fermez tous les événements et laissez le couvercle du grilloir fermé aussi longtemps que possible. Lors du retrait, placez-les soigneusement dans un récipient en métal incombustible. Saturer les charbons et les cendres avec de l'eau et laissez-les dans le récipient en métal pendant 24 heures avant de les jeter.
- Gardez les charbons éteints et les cendres loin des structures et des matériaux combustibles.
- Vaporisez ou arrosez les surfaces sous et autour du gril avec de l'eau jusqu'à ce qu'elles soient complètement humides, et ce afin d'éteindre les cendres, charbons ou braises qui pourraient être tombés pendant la cuisson ou le nettoyage.
- Rangez le gril dans un endroit sec, hors de portée des enfants et des animaux.

DÉPANNAGE

GUIDE DE RÉOLUTION

QUE FAIRE S'IL MANQUE DES PIÈCES À MA COMMANDE ?

S'il semble manquer des pièces à votre commande, contactez notre équipe du service client dans les 7 jours suivant la réception.

COMMENT NETTOYER LE BARBECUE FUMOIR GRILLOIR ?

Nous vous recommandons de nettoyer l'intérieur de votre grilloir lorsque l'élément sera entièrement refroidi. Veuillez utiliser de l'eau chaude savonneuse et la brosse métallique fournie. Pour le cadre, utilisez uniquement un chiffon doux et de l'eau chaude savonneuse. Assurez-vous de bien sécher le tout avant de le recouvrir avec la housse fournie.

**POUR TOUT AUTRE PROBLÈME, VEUILLEZ
CONTACTER NOTRE ÉQUIPE DU SERVICE CLIENT.**

MODE D'EMPLOI

INSTRUCTIONS DE MONTAGE

1. Vérifiez que vous disposez de toutes les pièces nécessaires pour assembler le barbecue.
2. Commencez par fixer le support fixe avant (35), le support fixe arrière (36) et les supports de roue (33) (34) au panneau inférieur (37) à l'aide de 8 vis M6 de 12 mm (A). Insérez maintenant l'essieu (32) à travers les trous sur les supports de roue (33) (34). Ensuite, placez les roues (31) à l'extrémité de chaque essieu et fixez-les avec le joint plat M8 (L) et les contre-écrous M8 (I).

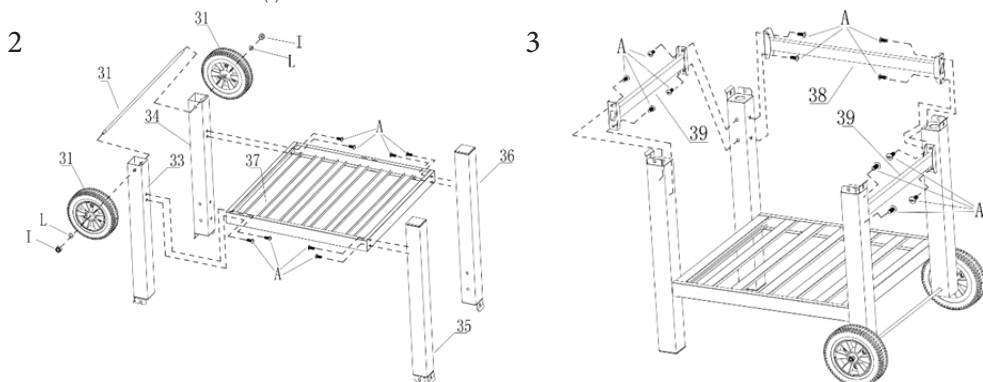

3. Maintenant, retournez le cadre de manière à ce que les roues et les pieds reposent sur le sol. Fixez ensuite les supports du cadre latéral (39) et le support du cadre arrière (38) à l'intérieur des pieds à l'aide de 12 vis M6 de 12 mm (A).

4. Connectez maintenant le panneau latéral gauche (26), le panneau arrière (27), le panneau avant (28) et le panneau latéral droit (29) ensemble à l'aide de 12 vis M6 de 12 mm.

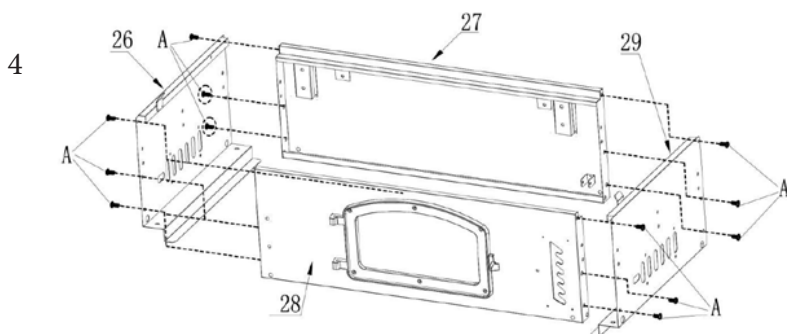

MODE D'EMPLOI

INSTRUCTIONS DE MONTAGE

5. Fixez ensuite le corps du fourneau que vous venez d'assembler aux pieds de la base assemblée à l'étape 3 à l'aide de 8 vis M6 de 12 mm(A)

5

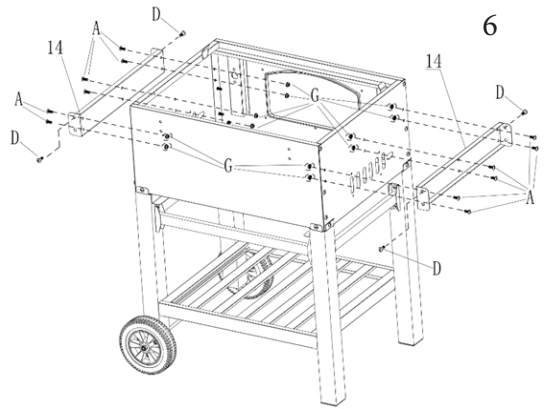
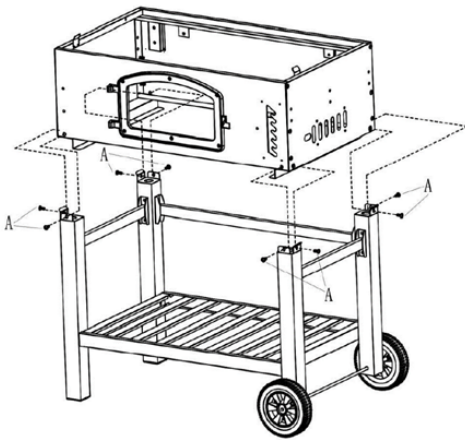

6

6. Placez les deux supports des panneaux latéraux (14) sur les deux panneaux latéraux et fixez-les à l'aide de 12 vis M6 de 12 mm(A), puis fixez-les avec 12 écrous à bride M6(G). Pré-installez les 4 vis M6 18mm (D) sur les barres de support du panneau latéral (14).

7. Fixez maintenant les événements d'aération (15) aux deux panneaux latéraux à l'aide de 8 vis M5 de 12 mm (E) et fixez-les avec 8 écrous à bride M5 (H). Fixez les poignées de ventilation (3) aux événements d'aération (15) avec les joints plats M4 (J) et la vis M4X10 (F).

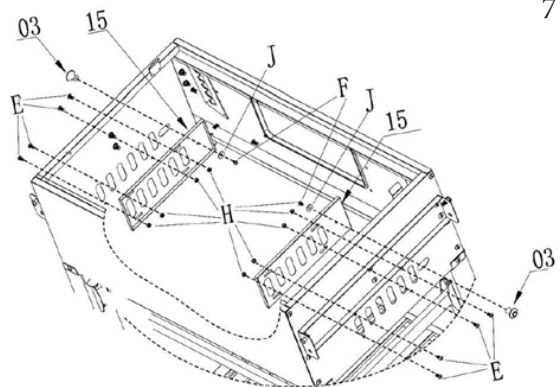

7

MODE D'EMPLOI

INSTRUCTIONS DE MONTAGE

- Fixez les supports inférieurs (24) au bac à charbon (15) avec 4 vis M6 de 12 mm (A) et fixez-les avec 4 écrous à bride M6 (G).
- Connectez le support supérieur droit (22) et le support supérieur gauche (21) à l'intérieur des bras inférieurs (25) à l'aide de 2 axes de charnière M5 de 8 mm (N) et fixez-les tous les deux avec une goupille (M).
- Fixez ensuite les deux bras inférieurs à l'extérieur des supports inférieurs (24) à l'aide de 2 axes de charnière M5 de 8 mm (N) et fixez chacun d'eux avec une goupille (M).
- Fixez la crémaillère (10) aux supports inférieurs à l'aide de 2 axes de charnière M5 de 8 mm (N) et fixez-les tous les deux avec une goupille (M).

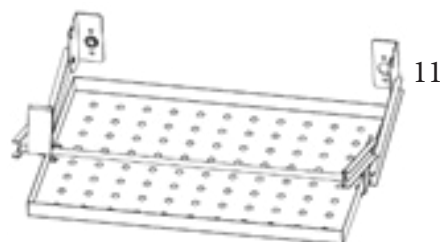
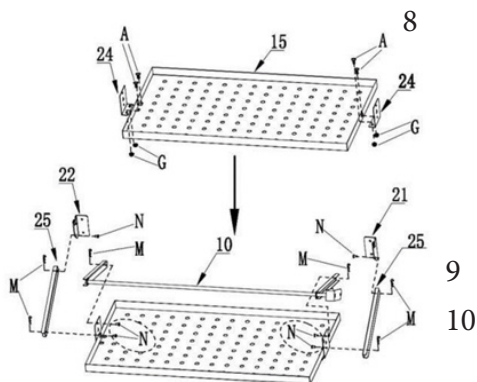

- Insérez le levier (23) à travers le panneau avant du côté droit, puis faites-le passer à travers le clapet coupe-feu (40) et la plaque d'ajustement de la hauteur (41). Fixez-le ensuite au panneau arrière à l'aide d'un axe de charnière M5 x 25 mm (P) et d'une goupille (M). Fixez maintenant la plaque d'ajustement de la hauteur (41) au levier à l'aide d'un axe de charnière M5 de 25 mm (P) et d'une goupille (M). Enfin, fixez l'axe de charnière M5 8 mm (N) à la tranche du clapet coupe-feu et au joint plat M6, et fixez-les avec une goupille (M).

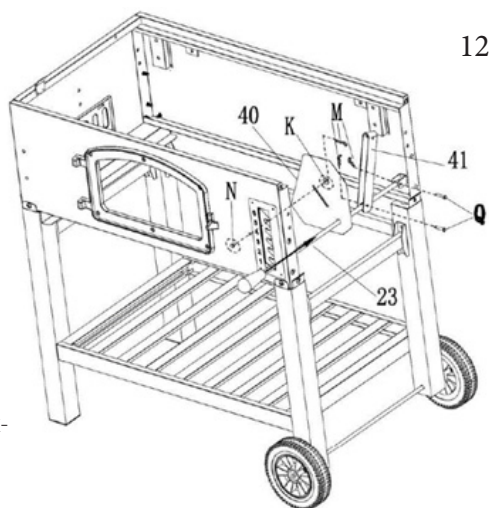

MODE D'EMPLOI

INSTRUCTIONS DE MONTAGE

13. Fixez les supports supérieurs droit et gauche au panneau avant à l'aide de 4 vis M5 de 12 mm (E). Insérez ensuite la crémaillère (10) dans les rainures des supports supérieurs gauche et droit (21,22).

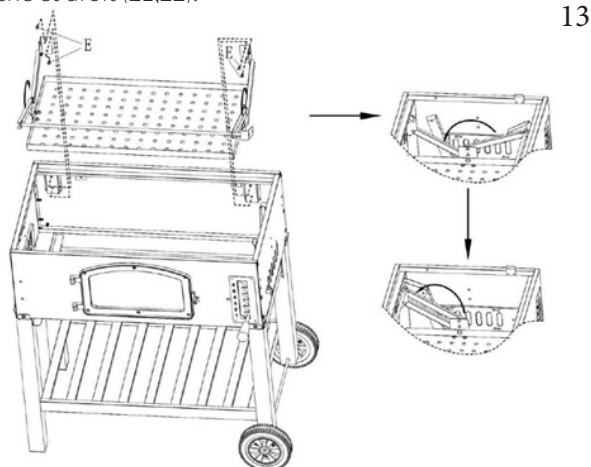

14. Fixez le support de levier (42) aux supports supérieurs gauche et droit à l'aide de 2 vis M4 de 10 mm (F). Fixez maintenant la plaque d'ajustement de la hauteur (10) à la crémaillère avec un axe de charnière M5 de 25 mm (P) et une goupille (M).

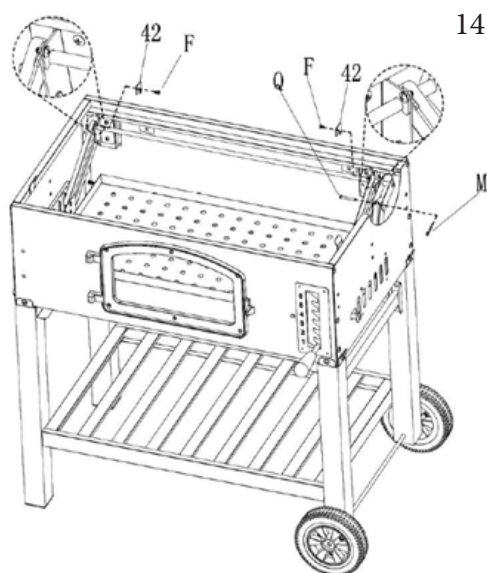

15. Fixez maintenant le décapsuleur (6) au panneau avant à l'aide de 2 vis M5 de 12 mm (E).

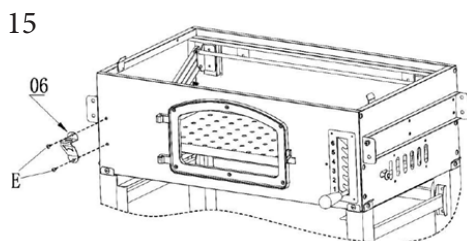

MODE D'EMPLOI

INSTRUCTIONS DE MONTAGE

16. Fixez la porte en fonte (30) au panneau avant à l'aide de 2 axes de charnière M5 45 mm (O) et fixez-les avec des goupilles (M).

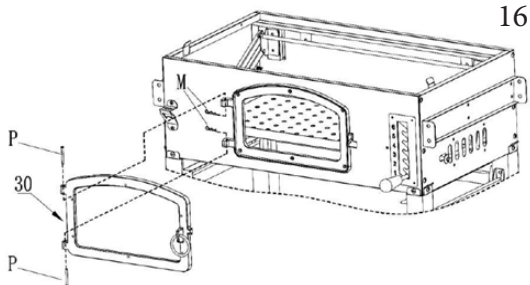

17. Placez maintenant la tablette latérale gauche (12) et la tablette latérale droite (13) sur les vis préinstallées (D) de l'étape 6. Fixez les deux tablettes latérales aux panneaux latéraux avec 4 vis M6 18 mm (D). Fixez les charnières inférieures (20) au panneau arrière à l'aide de 4 vis M6 de 35 mm (C) et fixez-les avec 4 écrous à bride M6 (G).

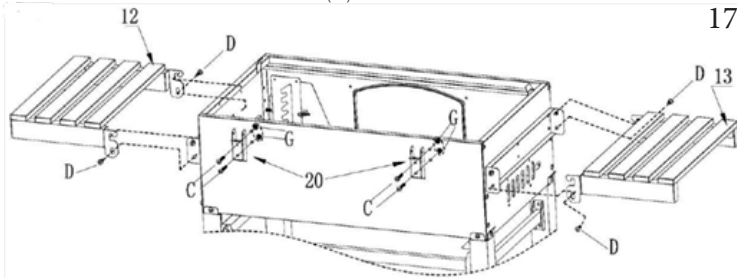

18. Fixez la poignée de bac à cendres (18) et la bride au bac à cendres (17) en utilisant 2x joints plats M6 (K) et 2x vis M6 20mm (B).

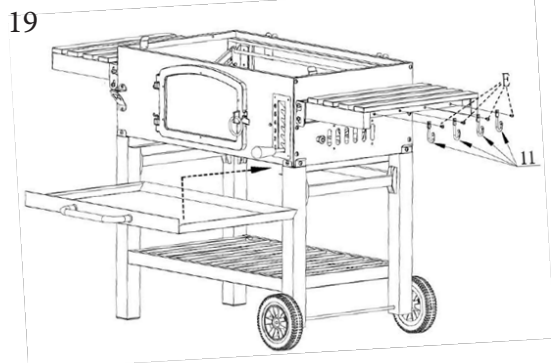
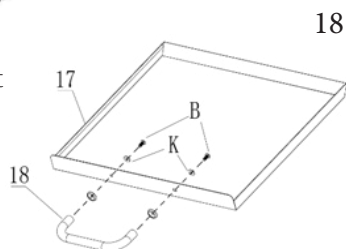

19. Glissez le bac à cendres à l'avant du grilloir, directement sous le panneau avant. Fixez ensuite les crochets latéraux (11) à l'étagère latérale droite avec 4 vis M5 de 12 mm (E).

MODE D'EMPLOI

INSTRUCTIONS DE MONTAGE

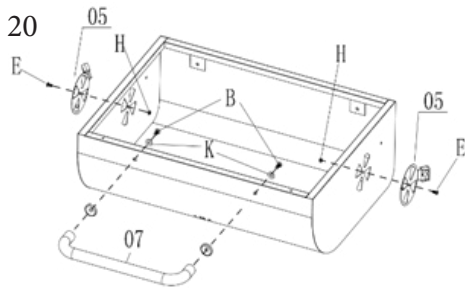

20. Pour assembler le couvercle, fixez la poignée du couvercle(7) et la bride au couvercle du grilloir (1) en utilisant 2x joints plats M6 (K) et 2xvis M6 20 mm (B). Fixez les événements du couvercle (5) de chaque coté du couvercle avec 2 vis M5 de 12 mm (E) et 2 écrous à bride M5 (H).
21. Fixez les charnières supérieures (19) au couvercle du grilloir à l'aide de 4 vis M6 de 35 mm (C) et de 4 écrous à bride M6 (G).

20. Pour assembler le couvercle, fixez la poignée du couvercle(7) et la bride au couvercle du grilloir (1) en utilisant 2x joints plats M6 (K) et 2xvis M6 20 mm (B). Fixez les événements du couvercle (5) de chaque coté du couvercle avec 2 vis M5 de 12 mm (E) et 2 écrous à bride M5 (H).

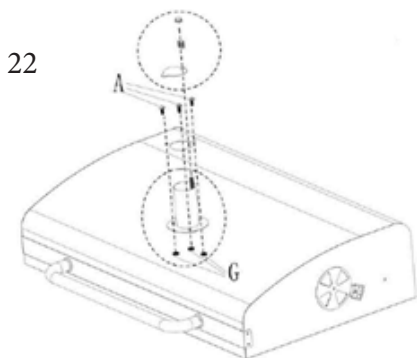
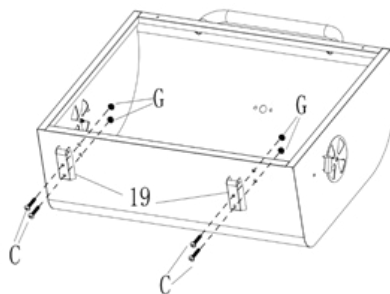

22. Vous pouvez maintenant attacher la cheminée au couvercle. Retirez d'abord le couvercle de la cheminée, puis faites glisser la cheminée (2) dans le couvercle du grilloir de l'intérieur. Fixez-les maintenant avec 3 vis M6 de 12 mm(A) et 3 écrous à bride M6 (G). Fixez le couvercle de la cheminée sur la cheminée avec le ressort et l'écrou de cheminée fournis.

23. Ensuite placez la jauge de température (4) à travers le trou présent sur le couvercle du grilloir et fixez-la avec les outils fournis.

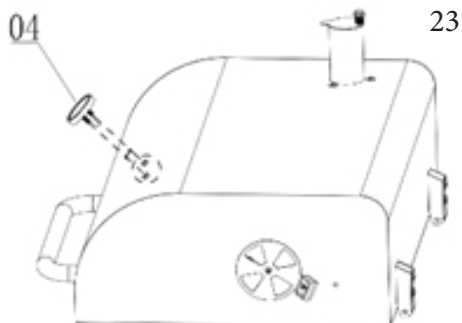

MODE D'EMPLOI

INSTRUCTIONS DE MONTAGE

24. Placez le couvercle du grilloir sur le grilloir, les charnières supérieures doivent s'adapter à l'intérieur des charnières inférieures. Connectez les charnières ensemble à l'aide de 2 axes de charnière M5 35 mm (Q) et de goupilles (M).

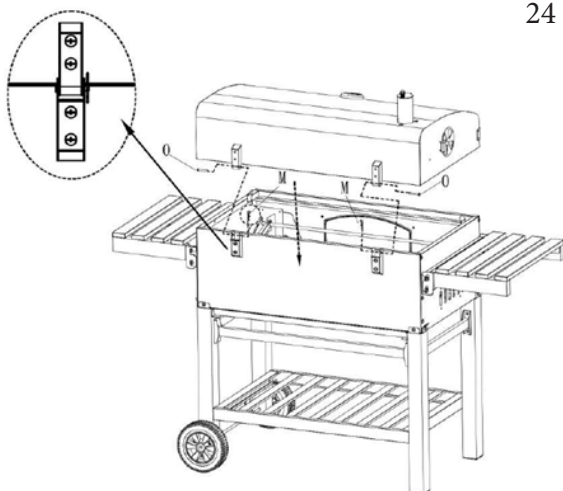

24

25. Enclenchez les côtés gauche et droit de la grille chauffante (8) dans les supports de grille à l'intérieur du couvercle du grilloir et fixez-le avec des goupilles (M). Placez les grilles de cuisson en fonte (9) sur le rebord supérieur du grilloir. Votre barbecue est prêt !

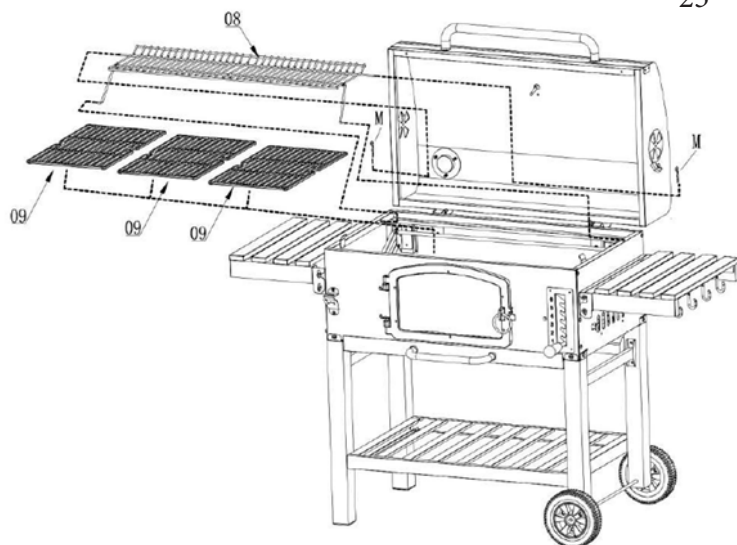

25

SPEZIFIKATIONEN

PRODUKTBESCHREIBUNG

Dieser Jardi BBQ Räuchergrill ist eine ideale Ergänzung für jeden Garten - egal ob Sie ein gelegentlicher Grillfan oder ein echter Grillmeister sind - dies ist das ultimative Gerät für Ihre Kochgefolgschaft. Mit der 6-fach höhenverstellbaren Kohlewanne können Sie sicher sein, dass Sie jeden Geschmack befriedigen können.

PRODUKTSPEZIFIKA



MATERIAL:	Stahl
ABMESSUNGEN:	111cm (H) x 142cm (B) x 62cm (T)
GRILLGRÖSSE:	77cm x 43,5cm
GEWICHT:	34.5KG

PRODUKTMERKMALE

- 6 höhenverstellbare Kohlewannen mit Griff
- 2 x klappbare Einlegeböden
- Temperaturanzeige
- Drahtbürste
- Wasserdichte Abdeckung

TEILELISTE

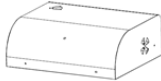
Wenn Sie Ihren BBQ-Räuchergrill zum ersten Mal auspacken, überprüfen Sie jedes Teil anhand dieser Liste, um sicherzustellen, dass sie alle vorhanden sind. Wenn etwas fehlt, kontaktieren Sie uns, bevor Sie versuchen den Grill zusammenzubauen.

Teil Nr.	Beschreibung	Abbildung	Menge
1	Grilldeckel		X 1
2	Schornstein		X 1

SPEZIFIKATION

PRODUKTMERKMALE

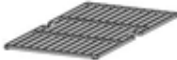

3	Entlüftungsgriffe		X 2
4	Temperaturmessgerät		X 1
5	Entlüftungsdeckel		X 2
6	Flaschenöffner		X 1
7	Deckelgriff		X 1
8	Warmhaltegestell		X 1
9	Gusseisen-Kochroste		X 3
10	Hubgestell		X 1
11	Haken		X 4
12	Rechte Seitenablage		X 1
13	Linke Seitenablage		X 1
14	Seitenwandstützleiste		X 2

Die Haftung von Monster Group UK Limited ist auf den Handelswert des Produkts beschränkt.













TEILELISTE

15	Entlüftungsöffnungen		X2
16	Holzkohle-Tablett		X1
17	Ascheschublade		X 1
18	Ascheschubladengriff		X 1
19	Obere Scharniere		X 2
20	Untere Scharniere		X 2
21	Linke obere Halterung		X 1
22	Rechte obere Halterung		X 1
23	Hebel		X 1
24	Untere Klammern		X 2
25	Untere Halterung		X 2
26	Linke Seitenwand		X 1
27	Rückwand		X 1
28	Frontplatte		X 1

TEILELISTE

29	Rechte Seitenwand		X 1
30	Tür aus Gusseisen		X 1
31	Räder		X 2
32	Achse		X 1
33	Vorderrad Bein		X 1
34	Hinterrad Bein		X 1
35	Standbein vorne		X 1
36	Standbein hinten		X 1
37	Bodenplatte		X 1
38	Rahmenträger hinten		X 1
39	Seitliche Rahmenträger		X 2
40	Brandschutzklappe		X 1
41	Höhenverstellbare Platte		X 1
42	Hebelstützbügel		X 2
A	M6 12mm Schraube		X 59

PARTS LIST

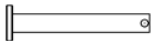
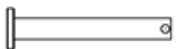
B	M6 20mm Schraube		X 4
C	M6 35mm Schraube		X 8
D	M6 18mm Schraube		X 8
E	M5 12mm Schraube		X 20
F	M4 10mm Schraube		X 2
G	M6 Mutter		X 27
H	M5 Mutter		X 10
I	M8 Sicherungsmutter		X 2
J	M4 Flachdichtung		X 2
K	M6 Flachdichtung		X 4
L	M8 Flachdichtung		X 2
M	Steckbolzen		X 13
N	M5 8mm Scharnierstift		X 6
O	M5 35mm Scharnierstift		X 2
P	M5 45mm Scharnierstift		X 2
Q	M5 45mm Scharnierstift		X 2

SICHERHEITSHINWEIS

SICHERES ARBEITEN

Bitte lesen Sie die Sicherheitshinweise durch, um Verletzungen oder Schäden am BBQ-Räuchergrill zu vermeiden.

- Vergewissern Sie sich, dass Sie die Gebrauchsanweisung und die Sicherheitshinweise gelesen und verstanden haben, bevor Sie das Produkt zusammenbauen.
- Achten Sie darauf, dass der Grill entsprechend dieser Anleitung gehandhabt und montiert wird.
- Verwenden Sie dieses Produkt nicht für andere als die vorgesehenen Zwecke.

SICHERHEIT DER GRILLPLATZIERUNG

- Verwenden Sie den Grill immer im Freien.
- Benutzen Sie den Grill NIEMALS in einem geschlossenen Raum oder unter einer Überdachung. Holzkohle erzeugt Kohlenmonoxid und sollte daher immer in einem gut belüfteten Bereich verbrannt werden.
- Verwenden Sie diesen Grill NICHT in einem Umkreis von 3m (10') von brennbarem Material, einschließlich, aber nicht beschränkt auf Sträucher, Bäume, Holz oder behandelte Holzdecks, Zäune, Terrassen, Veranden, Wände, Fahrzeuge, Benzin, Feuerzeugbenzin oder andere brennbare Flüssigkeiten.
- Verwenden Sie diesen Grill NUR auf einem harten, ebenen, nicht brennbaren, stabilen Untergrund, wie z. B. Beton, der das Gewicht des Grills tragen kann. NIEMALS auf Holz oder anderen brennbaren Oberflächen verwenden.
- Verwenden Sie diesen Grill NIEMALS dort, wo Kinder oder Haustiere mit dem Grill in Berührung kommen könnten.

SICHERHEIT BEI DER GRILLZUBEREITUNG

- Verwenden Sie den Grill NICHT ohne den Aschekasten.
- Benutzen Sie diesen Grill NICHT, wenn er nicht vollständig zusammengebaut ist und / oder Teile fehlen.

SICHERHEITSHINWEIS

SICHERES ARBEITEN

SICHERHEIT BEIM ANZÜNDEN VON HOLZKOHLE

- Wir empfehlen einen Holzkohle-Anzündkamin, um die Gefahren von Holzkohle-Anzündflüssigkeit zu vermeiden. Lesen und befolgen Sie **IMMER** die Anweisungen und Warnhinweise des Herstellers des Anzünders. Eine Nichtbeachtung kann zu schweren Verletzungen führen.
- Wenn Sie Anzündflüssigkeit für Holzkohle verwenden, verwenden Sie **NUR** Anzündflüssigkeit, die für das Anzünden von Holzkohle zugelassen ist.
- Verwenden Sie **NIEMALS** Benzin, Alkohol, Kerosin oder eine andere leicht entzündliche Flüssigkeit. Die Verwendung eines dieser oder ähnlicher Produkte kann zu einer Explosion führen, die schwere Verletzungen zur Folge haben kann.
- Säubern Sie vor dem Anzünden von Holzkohle **IMMER** die verschüttete Anzündflüssigkeit.
- Lassen Sie die Anzündflüssigkeit **IMMER** vollständig abbrennen, bevor Sie den Grilldeckel schließen. Andernfalls können sich Dämpfe im Grill festsetzen, die beim Öffnen des Deckels zu einem Flash-Brand oder einer Explosion führen können.
- Geben Sie **NIEMALS** Anzündflüssigkeit in heiße oder warme Kohlen. Es könnte zu einer Verpuffung kommen und Verbrennungen verursachen.
- Lagern Sie die Anzündflüssigkeit für Holzkohle **IMMER** in sicherer Entfernung vom Grill. Lagern Sie **KEINE** Anzündflüssigkeit oder andere brennbare Flüssigkeiten oder Materialien unter dem Grill.

SICHERHEIT BEIM GRILLEN

- Verwenden Sie den Grill **NICHT** bei Wind.
- Lassen Sie einen heißen Grill **NIEMALS** unbeaufsichtigt.
- Der Grill ist heiß, wenn er in Betrieb ist. Um Verbrennungen zu vermeiden:
 - Versuchen Sie **NICHT**, den Grill zu bewegen, solange er noch heiß ist.
 - Tragen Sie **IMMER** Schutzhandschuhe oder Ofenhandschuhe.
 - Berühren Sie keine heißen Grillflächen.
- Tragen Sie **KEINE** weite Kleidung und lassen Sie Ihr Haar nicht mit dem Grill in Berührung kommen.

SICHERHEITSHINWEIS

SICHERES ARBEITEN

- Fügen Sie NIEMALS vorgetränkte Holzkohle zu heißer oder warmer Kohle oder Asche hinzu. Es kann zu gefährlichen oder explosiven Verpuffungen kommen, die zu körperlichen Schäden führen können.
- Seien Sie äußerst vorsichtig, wenn Sie während des Grillens Holzkohle und/oder Holz nachlegen, da die Holzkohle noch heiß ist und Verbrennungen verursachen kann.
- Öffnen Sie den Deckel IMMER vollständig und sichern Sie ihn, um ein unerwartetes Schließen zu verhindern.
- Legen Sie NIEMALS mehr als 3,6 kg (8 lb) auf einen der Einlegeböden. Lehnen Sie sich NICHT an den Grill.
- Fügen Sie beim Räuchern NIEMALS Wasser hinzu, da heißes Wasser auf die Kohlen spritzen und einen Dampfstoß und heiße Asche verursachen kann.
- Beim Grillen kann Fett vom Grillgut auf die Holzkohle tropfen und einen Fettbrand verursachen. Schließen Sie in diesem Fall den Deckel und die Lüftungsschlitze, um die Flamme zu ersticken. Verwenden Sie NIEMALS Wasser, um einen Fettbrand zu löschen.
- Halten Sie Hände, Gesicht und Körper in sicherer Entfernung vom Grill, wenn Sie den Deckel öffnen. Wenn Flammen oder heiße Kohlen auf einen erhöhten Luftstrom treffen, kann es zu einer Verpuffung kommen.
- Versuchen Sie NIEMALS, den Aschekasten zu entfernen, solange die Kohlen heiß sind. Dies könnte zu Verbrennungen führen.

SICHERHEIT NACH GEBRAUCH

- Lassen Sie den Grill und die Komponenten IMMER vollständig abkühlen, bevor Sie damit umgehen.
- Stellen Sie sicher, dass der Grill vollständig abgekühlt ist, bevor Sie ihn mit dem mitgelieferten Deckel abdecken.
- Entfernen Sie die Asche oder die verbrauchten Kohlen NICHT vom Grill, bevor sie nicht vollständig erloschen sind.

SICHERHEITSHINWEIS

SICHERES ARBEITEN

SICHERHEIT NACH GEBRAUCH

- Um die Holzkohle zu löschen, schließen Sie alle Lüftungsöffnungen und schließen Sie den Grilldeckel so lange wie möglich. Wenn sie entfernt werden müssen, geben Sie sie vorsichtig in einen nicht brennbaren Metallbehälter. Tränken Sie die Kohlen und die Asche mit Wasser und lassen Sie sie 24 Stunden lang in dem Metallbehälter, bevor Sie sie entsorgen.
- Halten Sie gelöschte Kohlen und Asche sicher von brennbaren Strukturen und Materialien fern.
- Besprühen Sie die Flächen unter und um den Grill mit Wasser, bis sie vollständig nass sind, um Asche, Kohlen oder Glut zu löschen, die beim Grillen oder Reinigen heruntergefallen sind.
- Bewahren Sie den Grill an einem trockenen Ort außerhalb der Reichweite von Kindern und Haustieren auf, wenn er nicht benutzt wird.

FEHLERBEHEBUNG

LÖSUNGSGUIDE

WAS MACHE ICH, WENN BEI MEINER BESTELLUNG TEILE FEHLEN?

Falls bei Ihrer Bestellung ein Teil zu fehlen scheint, wenden Sie sich bitte innerhalb von 7 Tagen nach Erhalt der Ware an unser freundliches und hilfsbereites Kundenservice-Team.

WIE REINIGE ICH MEINEN BBQ RÄUCHERGRILL?

Wir empfehlen Ihnen, das Innere Ihres Grills, sobald es sicher ist, mit einer Kombination aus heißem Seifenwasser und Ihrer kostenlosen Drahtbürste zu reinigen. Für den Rahmen verwenden Sie bitte nur ein weiches Tuch und heißes Seifenwasser. Trocknen Sie ihn gründlich ab, bevor Sie ihn mit dem mitgelieferten Deckel abdecken.

**FÜR ALLE ANDEREN FRAGEN WENDEN SIE SICH BITTE AN
UNSER KUNDENSERVICE-TEAM.**

BENUTZERLEITFADEN

MONTAGEANLEITUNGEN

1. Überprüfen Sie, ob Sie alle Teile haben, die für den Zusammenbau des BBQ-Räuchergrills benötigt werden.
2. Befestigen Sie zunächst das vordere Standbein (35), das hintere Standbein (36) und die Radbeine (33) (34) mit 8x M6 12mm Schrauben (A) an der Bodenplatte (37). Stecken Sie nun die Achse (32) durch die Löcher an den Radbeinen (33) (34). Setzen Sie dann die Räder (31) auf das Ende jeder Achse und befestigen Sie sie mit der M8 Flachdichtung (L) und den M8 Muttern (I).

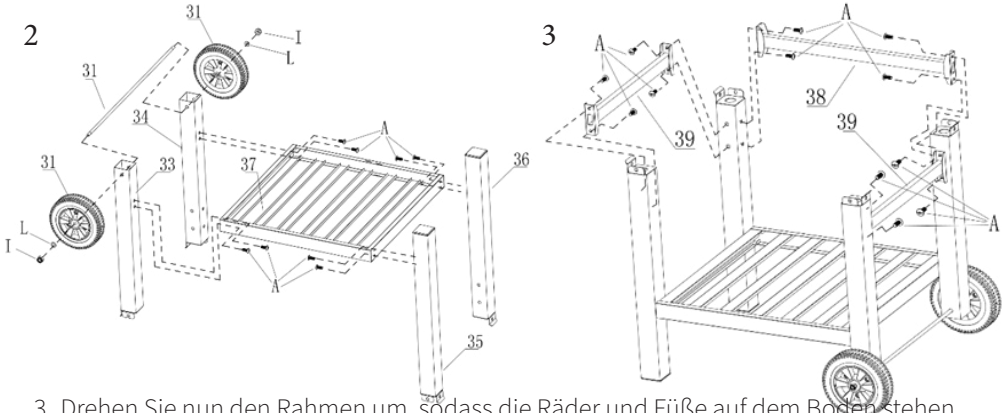

3. Drehen Sie nun den Rahmen um, sodass die Räder und Füße auf dem Boden stehen. Befestigen Sie nun die seitlichen Rahmenträger (39) und den hinteren Rahmenträger (38) mit 12x M6 12mm Schrauben (A) an der Innenseite der Beine.
4. Verbinden Sie nun die linke Seitenwand (26), die Rückwand (27), die Frontplatte (28) und die rechte Seitenwand (29) mit 12x M6 12mm Schrauben (A).

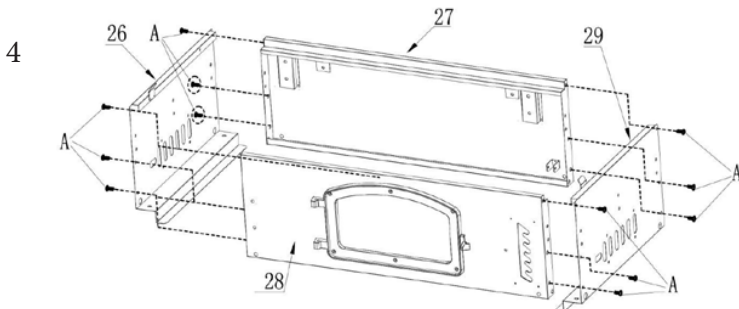

BENUTZERLEITFADEN

MONTAGEANLEITUNGEN

5. Befestigen Sie nun den soeben zusammengebauten Ofenkörper mit 8x M6 12mm Schrauben (A) an den Beinen der in Schritt 3 zusammengebauten Basis.

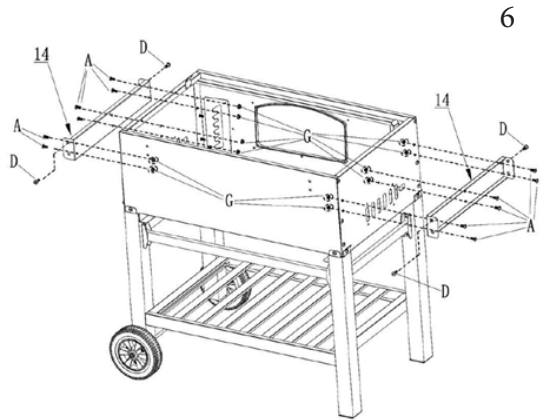
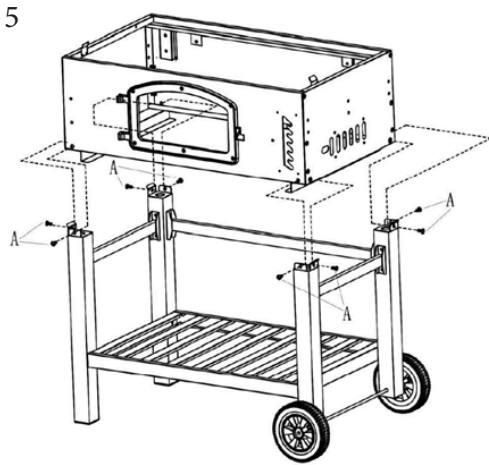

6. Bringen Sie die beiden Seitenwandstützleisten (14) an den beiden Seitenwänden an und befestigen Sie sie mit 12x M6 12mm Schrauben (A), dann sichern Sie sie mit 12x M6 Muttern (G). Montieren Sie die 4x M6 18mm Schrauben (D) an den Seitenwandstützleisten (14) vor.

7. Befestigen Sie nun die Entlüftungsöffnungen (15) mit 8x M5 12mm Schrauben (E) an den beiden Seitenteilen und sichern Sie sie mit 8x M5 Muttern (H). Befestigen Sie die Entlüftungsriffe (3) mit den M4 Flachdichtungen (J) und der M4X10 Schraube (F) an den Entlüftungsöffnungen (15).

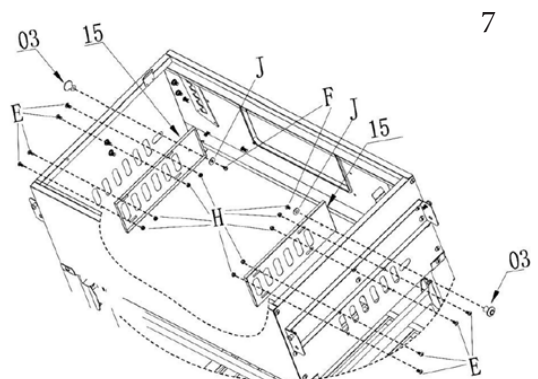

BENUTZERLEITFADEN

MONTAGEANLEITUNGEN

8. Befestigen Sie die unteren Klammern (24) mit 4x M6 12mm Schrauben (A) an dem Holzkohle-Tablett (16) und sichern Sie sie mit 4x M6 Flanschmuttern (G).

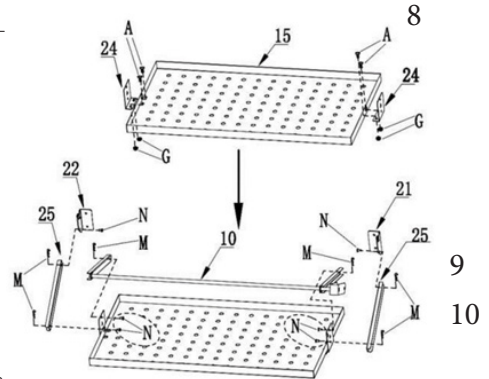

9. Verbinden Sie die rechte obere Halterung (22) und die linke obere Halterung (21) an der Innenseite der unteren Halterung (25) mit 2x M5 8mm Scharnierstiften (N) und sichern Sie beide mit einem Steckbolzen (M).

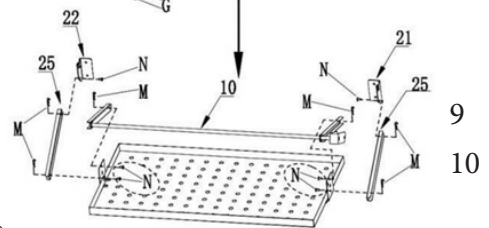

10. Befestigen Sie nun die beiden unteren Halterungen mit 2x M5 8mm Scharnierstiften (N) an der Außenseite der unteren Halterungen (24) und sichern Sie diese jeweils mit einem Steckbolzen (M).

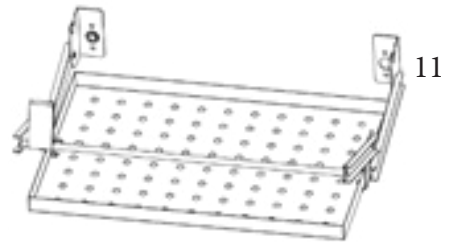

11. Befestigen Sie das Hubgestell (10) mit 2x M5 8mm Scharnierstift (N) an den unteren Halterungen und sichern Sie beide mit einem Steckbolzen (M).

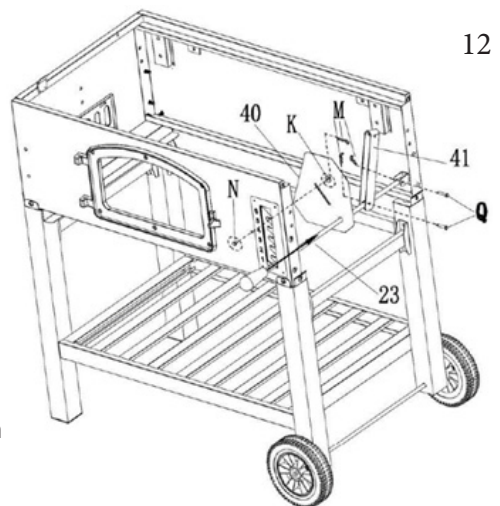

12. Führen Sie den Hebel (23) auf der rechten Seite durch die Frontplatte und dann sowohl durch die Brandschutzklappe (40) als auch durch die höhenverstellbare Platte (41). Befestigen Sie ihn dann mit einem M5 x 25 mm Scharnierstift (P) und einem Steckbolzen (M) an der Rückwand. Befestigen Sie nun die höhenverstellbare Platte (41) mit einem M5 25mm Scharnierstift (P) und einem Steckbolzen (M) am Hebel. Zum Schluss befestigen Sie den M5 8mm Scharnierstift (N) an der Brandschutzklappenscheibe und der M6 Flachdichtung und sichern diese mit einem Steckbolzen (M).

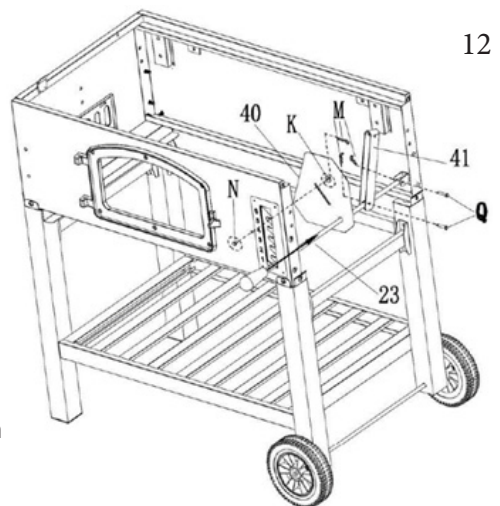

BENUTZERLEITFADEN

MONTAGEANLEITUNGEN

13. Befestigen Sie die rechte und linke obere Halterung mit 4x M5 12mm Schrauben (E) an der Frontplatte. Lassen Sie dann das Hubgestell (10) in die Nuten der linken und rechten oberen Halterung (21, 22) fallen.

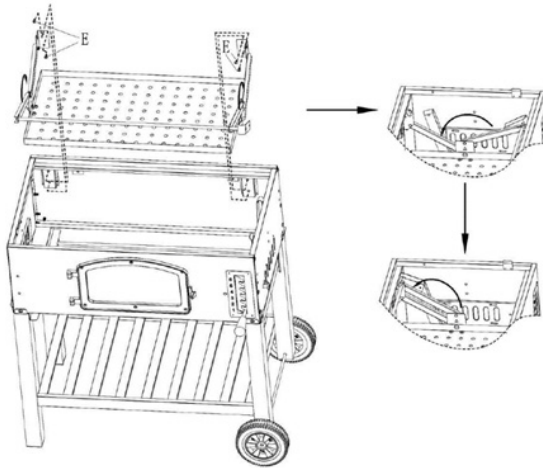

14. Befestigen Sie den Hebelstützbügel (42) mit 2x M4 10mm Schrauben (F) an der linken und rechten oberen Halterung. Befestigen Sie nun das Hubgestell (10) mit einem M5 25mm Scharnierstift (P) und einem Steckbolzen (M).

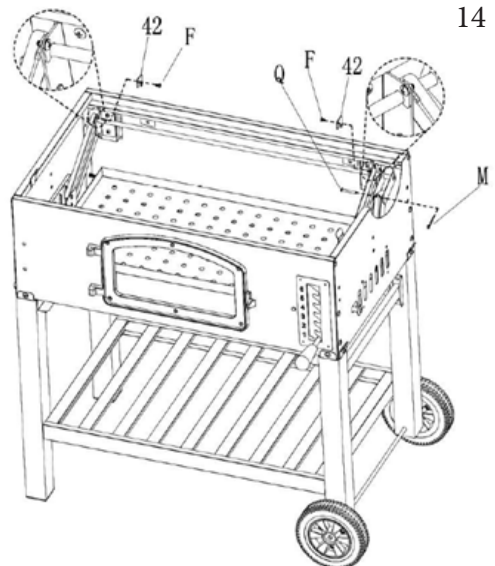

15. Befestigen Sie nun den Flaschenöffner (6) mit 2x M5 12mm Schrauben (E) an der Frontplatte.

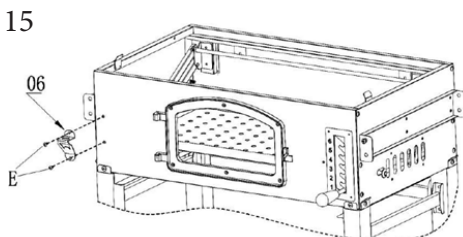

BENUTZERLEITFADEN

MONTAGEANLEITUNGEN

16

16. Befestigen Sie die Tür aus Gusseisen (30) mit 2x M5 45mm Scharnierstiften (O) an der Frontplatte und sichern Sie sie mit Steckbolzen (M).

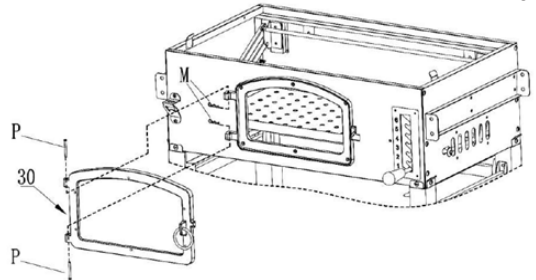

17. Setzen Sie nun die linke Seitenablage (12) und die rechte Seitenablage (13) auf die vorinstallierten Schrauben (D) aus Schritt 6. Befestigen Sie beide Seitenböden mit 4x M6 18mm Schrauben (D) an den Seitenwänden. Befestigen Sie die unteren Scharniere (20) mit 4x M6 35mm Schrauben (C) an der Rückwand und sichern Sie diese mit 4x M6 Muttern (G).

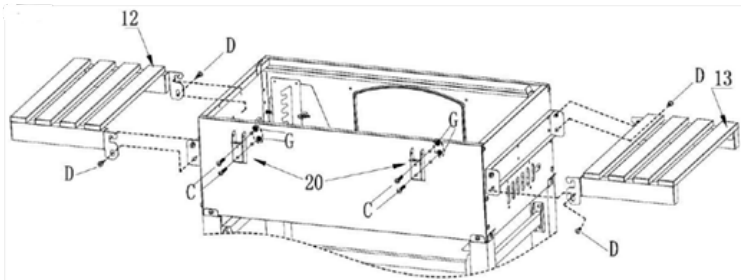

17

18. Befestigen Sie den Ascheschubladengriff (18) und den Aschenbecherflansch mit Hilfe von 2x M6 Flachdichtungen (K) und 2x M6 20mm Schrauben (B) an der Ascheschublade (17).

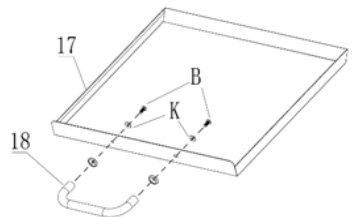

18

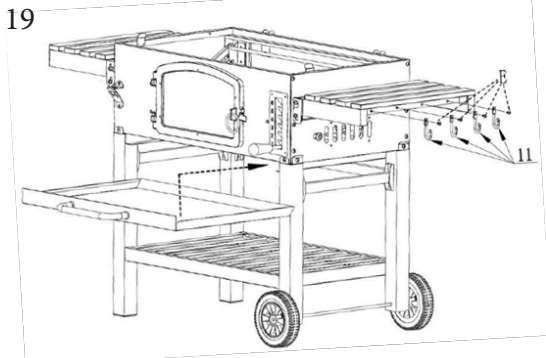

19

19. Schieben Sie den Aschekasten in die Vorderseite des Grills, direkt unter die Frontplatte. Befestigen Sie dann die Haken (11) mit 4x M5 12mm Schrauben (E) an der rechten Seitenablage.

BENUTZERLEITFADEN

MONTAGEANLEITUNGEN

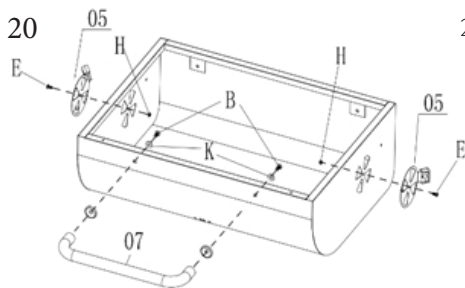

20. Um den Deckel zu montieren, befestigen Sie den Deckelgriff (7) und den Deckelgriffflansch mit 2x M6 Flachdichtungen (K) und 2x M6 20mm Schrauben (B) am Grilldeckel (1). Befestigen Sie die Entlüftungsdeckel (5) auf beiden Seiten des Deckels mit 2x M5 12mm Schrauben (E) und 2x M5 Muttern (H).

21. Befestigen Sie die oberen Scharniere (19) mit 4x M6 35mm Schrauben (C) und 4x M6 Muttern (G) am Grilldeckel.

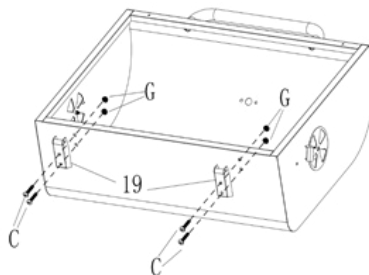

21

22

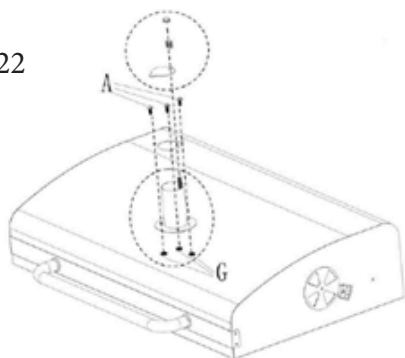

22. Nun befestigen Sie den Schornstein am Deckel. Nehmen Sie zuerst den Schornsteindeckel ab, dann schieben Sie den Schornstein (2) von innen in den Grilldeckel. Befestigen Sie diese nun mit 3x M6 12mm Schrauben (A) und 3x M6 Muttern (G). Befestigen Sie den Schornsteindeckel wieder auf dem Schornstein mit der mitgelieferten Feder und der Schornsteinmutter.

23. Stecken Sie dann das Temperaturmessgerät (4) durch das Loch im Grilldeckel und befestigen Sie ihn mit den mitgelieferten Schrauben.

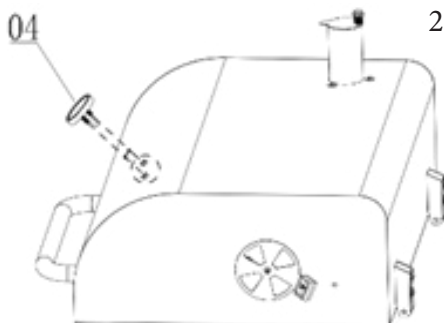

23

BENUTZERLEITFADEN

MONTAGEANLEITUNGEN

24. Legen Sie den Grilldeckel auf den Grillkörper, die oberen Scharniere sollten in die unteren Scharniere passen. Verbinden Sie die Scharniere mit 2x M5 35mm Scharnierstiften (Q) und Steckbolzen (M).

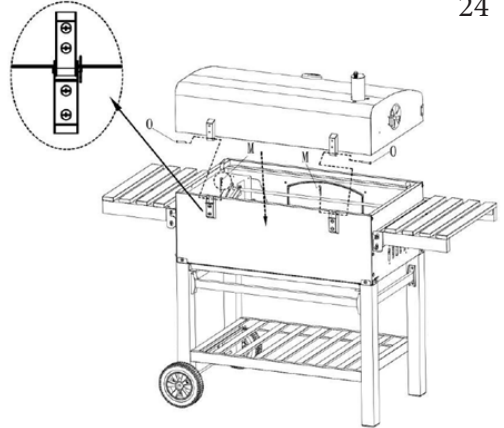

24

25. Rasten Sie die linke und rechte Seite des Warmhalterosts (8) in die Rosthalterungen im Grilldeckel ein und sichern Sie ihn mit Steckbolzen (M). Legen Sie die Grillroste (9) auf die obere Leiste des Grillkörpers. Sie sollten nun Ihren BBQ Räuchergrill vollständig zusammengebaut haben!

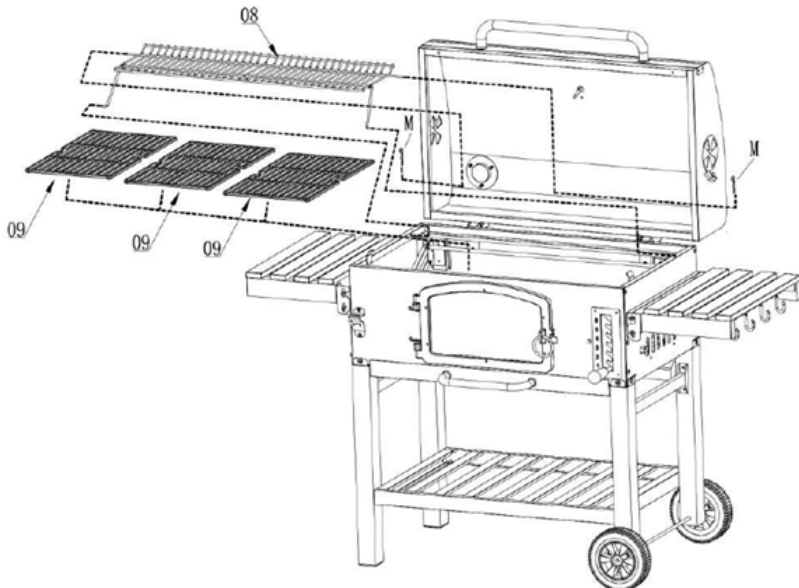

25



ESPECIFICACIONES

DESCRIPCIÓN DEL PRODUCTO

Esta barbacoa parrilla y ahumador de Jardí es un complemento ideal para cualquier jardín. Tanto si le gusta la barbacoa de vez en cuando como si es un verdadero maestro de la parrilla, ésta es la herramienta definitiva para añadir a su equipo de cocina. Gracias a la bandeja de carbón, con 6 alturas ajustables, puede tener por segura que satisfará las papilas gustativas de cualquiera.

ESPECIFICACIONES DEL PRODUCTO



MATERIAL:	Acero
DIMENSIONES:	111cm (Altura) x 142cm (Anchura) x 62cm (Profundidad)
TAMAÑO DE LA PARRILLA:	77cm x 43,5cm
PESO:	34,5KG

CARACTERÍSTICAS DEL PRODUCTO

- 6 bandejas de carbón de altura regulable con asa
- 2 x Estantes plegables
- Indicador de temperatura
- Cepillo de alambre
- Cubierta impermeable

LISTA DE PIEZAS

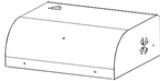
Cuando desembale por primera vez su barbacoa ahumador, compruebe cada pieza consultando esta lista para asegurarse de que están todas presentes. Si falta alguna, póngase en contacto con nosotros antes del montaje.

Nº de Pieza	Descripción	Ilustración	Cantidad
1	Tapa de la parrilla		X 1
2	Chimenea		X 1

ESPECIFICACIONES

CARACTERÍSTICAS DEL PRODUCTO

3	Asas de ventilación		X 2
4	Indicador de temperatura		X 1
5	Tapas de ventilación		X 2
6	Abridor de botella		X 1
7	Asa de la tapa		X 1
8	Rejilla para calentar		X 1
9	Parrillas para cocinar		X 3
10	Barra elevadora		X 1
11	Ganchos		X 4
12	Estante lateral derecho		X 1
13	Estante lateral izquierdo		X 1
14	Barra de soporte del panel lateral		X 2

La responsabilidad de Monster Group UK Limited estará limitada únicamente al valor comercial del producto.

LISTA DE PIEZAS

15	Rejillas de ventilación		X2
16	Bandeja de carbón vegetal		X1
17	Cenicero		X 1
18	Asa del cenicero		X 1
19	Bisagras superiores		X 2
20	Bisagras inferiores		X 2
21	Escuadra superior izquierda		X 1
22	Escuadra superior derecha		X 1
23	Maneta		X 1
24	Escuadras inferiores		X 2
25	Brazos inferiores		X 2
26	Panel lateral izquierdo		X 1
27	Panel trasero		X 1
28	Panel frontal		X 1

LISTA DE PIEZAS

29	Panel lateral derecho		X 1
30	Puerta de hierro fundido		X 1
31	Ruedas		X 2
32	Eje		X 1
33	Pata de la rueda delantera		X 1
34	Pata de la rueda trasera		X 1
35	Pata delantera izquierda fija		X 1
36	Pata trasera fija		X 1
37	Panel inferior		X 1
38	Travesaño trasero de la estructura		X 1
39	Travesaños laterales de la estructura		X 2
40	Compuerta cortafuegos		X 1
41	Placa de regulación de altura		X 1
42	Soporte de la maneta		X 2
A	Tornillo M6 12mm		X 59

LISTA DE PIEZAS

B	Tornillo M6 20mm		X 4
C	Tornillo M6 35mm		X 8
D	Tornillo M6 18mm		X 8
E	Tornillo M5 12mm		X 20
F	Tornillo M4 10mm		X 4
G	Tuerca con reborde M6		X 27
H	Tuerca con reborde M5		X 10
I	Tuerca de bloqueo M8		X 2
J	Junta plana M4		X 2
K	Junta plana M6		X 5
L	Junta plana M8		X 2
M	Clavija		X 16
N	Eje de bisagra M5 8mm		X 7
O	Eje de bisagra M5 35mm		X 2
P	Eje de bisagra M5 45mm		X 2
Q	Eje de bisagra M5 45mm		X 2

CONSEJOS DE SEGURIDAD

PRÁCTICAS DE TRABAJO SEGURAS

Por favor, lea las Prácticas de Trabajo Seguras para garantizar la prevención de lesiones o daños en la barbacoa con parrilla y ahumador.

- Asegúrese de haber leído y comprendido íntegramente el manual de instrucciones y los consejos de seguridad antes del montaje de este producto.
- Asegúrese de montar y manipular la barbacoa según las instrucciones.
- No utilice este producto para fines distintos a los previstos.

SEGURIDAD A LA HORA DE COLOCAR LA PARRILLA

- Utilice siempre la barbacoa al aire libre.
- NUNCA utilice la barbacoa en un espacio cerrado o bajo una zona cubierta. El carbón vegetal genera monóxido de carbono y, por lo tanto, debe quemarse siempre en un área bien ventilada.
- NO utilice esta barbacoa a menos de 10'(3m) de cualquier material combustible, incluidos, entre otros, arbustos, árboles, madera o cubiertas de madera tratada, vallas, patios, porches, paredes, vehículos, gasolina, líquido para encendedores o cualquier otro líquido inflamable.
- Utilice esta barbacoa ÚNICAMENTE en una superficie dura, nivelada, incombustible y estable, como el hormigón, que pueda soportar el peso de la barbacoa. NUNCA la utilice sobre madera u otras superficies combustibles.
- NUNCA use esta barbacoa donde niños o mascotas puedan tener contacto con la barbacoa.

SEGURIDAD A LA HORA DE PREPARAR LA BARBACOA

- NO use la barbacoa sin que esté colocado el cenicero.
- NO utilice la barbacoa a menos que esté completamente montada y todas las piezas estén en funcionamiento.

CONSEJOS DE SEGURIDAD

PRÁCTICAS DE TRABAJO SEGURAS

SEGURIDAD A LA HORA DE PRENDER EL CARBÓN

- Recomendamos un encendedor de chimenea de carbón para evitar los peligros derivados del líquido encendedor de carbón. Lea y siga SIEMPRE las instrucciones y advertencias del fabricante del encendedor de chimeneas. Si no lo hace, podría sufrir lesiones graves.
- Si utiliza líquido de encendido de carbón, utilice SÓLO líquido de encendido aprobado para encender carbón.
- NUNCA utilice gasolina, alcohol, queroseno o cualquier otro líquido altamente inflamable. El uso de cualquiera de estos productos o de productos similares podría provocar una explosión, que podría llevar a graves lesiones físicas.
- Limpie SIEMPRE cualquier líquido de encendido que se haya derramado antes de prender el carbón.
- Deje SIEMPRE que el líquido de encendido de carbón se consuma completamente antes de cerrar la tapa de la barbacoa. Si no lo hace, los humos podrían quedar atrapados en la barbacoa y provocar un incendio o una explosión al abrir la tapa.
- NUNCA añada líquido encendedor de carbón sobre brasas calientes o templadas. Podrían producirse llamaradas y causar quemaduras.
- Almacene SIEMPRE el líquido encendedor de carbón a una distancia segura de la barbacoa. NO guarde el líquido encendedor ni otros líquidos o materiales inflamables debajo de la barbacoa.

SEGURIDAD A LA HORA DE USAR LA BARBACOA

- NO utilice la barbacoa en condiciones ventosas.
- NUNCA deje la barbacoa caliente sin supervisión.
- La barbacoa está caliente cuando está en uso. Para evitar quemaduras:
 - NO intente mover la barbacoa mientras esté encendida o aún caliente.
 - Utilice SIEMPRE guantes de protección o guantes de cocina.
 - NO TOQUE las superficies calientes de la parrilla.
- NO lleve ropa suelta ni permita que el pelo entre en contacto con la parrilla.
- NUNCA añada carbón previamente humedecido a las brasas o cenizas calientes o templadas. Podrían producirse llamaradas peligrosas o explosivas y provocar daños corporales.
- 60 • TENGA EXTREMA CUIDADO al añadir carbón y/o leña a la parrilla mientras está cocinando, ya que el carbón aún está caliente y puede provocar quemaduras.

CONSEJOS DE SEGURIDAD

PRÁCTICAS DE TRABAJO SEGURAS

- Abra SIEMPRE la tapa completamente y asegúrela para evitar que se cierre inesperadamente.
- NUNCA coloque más de 3,6 kg (8 lb) en ninguno de los estantes. NO se apoye en ningún estante.
- NUNCA añada agua cuando esté ahumando, ya que el agua caliente puede salpicar las brasas creando una ráfaga de vapor y ceniza caliente.
- Al cocinar a la parrilla, la grasa de los alimentos puede gotear sobre el carbón y provocar un incendio. Si esto ocurre, cierre la tapa y las ventilas para sofocar la llama. NUNCA utilice agua para extinguir un incendio provocado por la grasa.
- Mantenga las manos, la cara y el cuerpo a una distancia segura de la parrilla al abrir la tapa. Cuando las llamas o las brasas calientes topan con una mayor corriente de aire, pueden producirse llamaradas.
- NUNCA intente retirar el cenicero mientras las brasas estén calientes. Hacerlo podría provocar quemaduras.

SEGURIDAD DESPUÉS DEL USO

- Deje SIEMPRE que la barbacoa y todas sus partes se enfríen completamente antes de manipularlas.
- Asegúrese de que la parrilla se haya enfriado por completo antes de cubrirla con la cubierta suministrada.
- NO retire las cenizas o el carbón usado de la barbacoa hasta que estén completamente apagados.
- Para extinguir el carbón, cierre todas las ventilaciones y cierre la tapa de la barbacoa durante el mayor tiempo posible. Cuando deba retirarlo, colóquelo cuidadosamente en un recipiente metálico incombustible. Impregne los carbones y las cenizas con agua y deje que permanezcan en el recipiente metálico durante 24 horas antes de desecharlos.
- Mantenga los carbones y las cenizas apagados alejados de estructuras y materiales combustibles.
- Rocíe y humedezca las superficies debajo y alrededor de la barbacoa con agua hasta que estén completamente mojadas para extinguir las cenizas, carbones o brasas que puedan haber caído durante la parrillada o la limpieza.
- Guarde la barbacoa en un lugar seco y fuera del alcance de los niños y las mascotas cuando no la utilice.

GUÍA DEL USUARIO

INSTRUCCIONES DE ENSAMBLAJE

1. Compruebe que dispone de todas las piezas necesarias para montar la barbacoa con parrilla y ahumador.
2. Comience por colocar la pata fija delantera (35), la pata fija trasera (36) y las patas con ruedas (33) (34) en el panel inferior (37) usando 8 tornillos M6 de 12 mm (A). Ahora, introduzca el eje (31) por los agujeros de las patas de las ruedas (33) (34). A continuación, coloque las ruedas (31) en el extremo de cada eje y fíjelas con la junta plana M8 (L) y las tuercas de seguridad M8 (I).

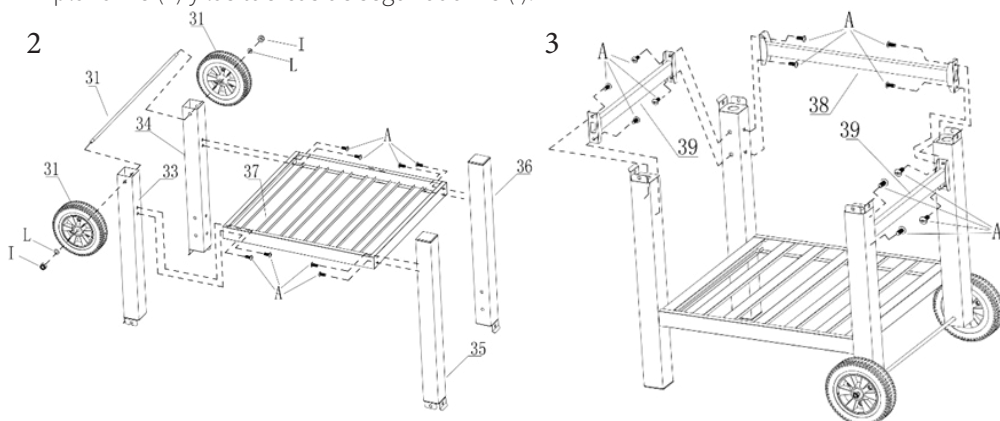

3. Ahora, gire la estructura para que las ruedas y los pies queden en el suelo. A continuación, fije los travesaños laterales de la estructura (39) y el travesaño trasero de la estructura (38) a la parte interior de las patas con tornillos 12x M6 de 12 mm (A).
4. Ahora conecte el panel lateral izquierdo (26), el panel trasero (27), el panel frontal (28) y el panel lateral derecho (29) con 12 tornillos M6 de 12 mm (A).

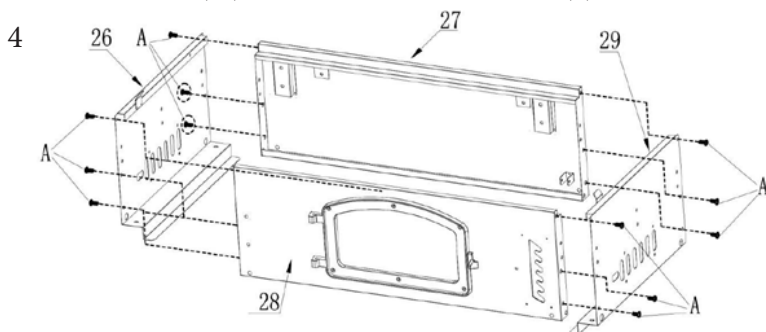

GUÍA DEL USUARIO

INSTRUCCIONES DE ENSAMBLAJE

5. A continuación, fije el cuerpo del horno que acaba de montar a las patas de la base montada en el paso 3 con 8 tornillos M6 de 12 mm (A).

5

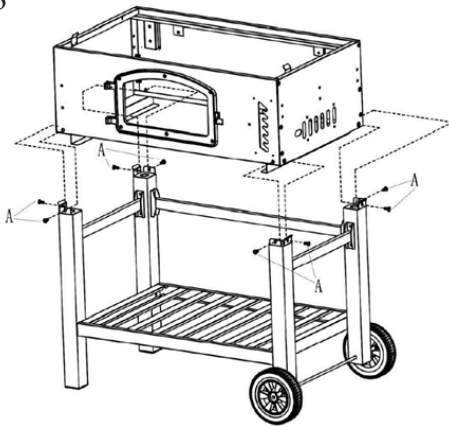

6

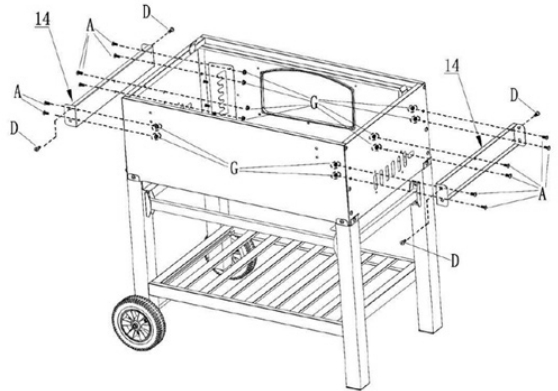

6. Ahora fije las rejillas de ventilación (15) a los dos paneles laterales con 8 tornillos M5 de 12 mm (E) y asegúrelos con 8 tuercas con reborde M5 (H). Fije las asas de ventilación (3) a las rejillas de ventilación (15) con las juntas planas M4 (J) y los tornillos M4 de 10 mm (F)

7. Ahora fije las rejillas de ventilación (15) a los dos paneles laterales con 8 tornillos M5 de 12 mm (E) y asegúrelos con 8 tuercas con reborde M5 (H). Fije las asas de ventilación (3) a las rejillas de ventilación (15) con las juntas planas M4 (J) y el tornillo M4 de 10 mm (F). Fije las escuadras inferiores (24) a la bandeja de carbón (15) con 4 tornillos M6 de 12 mm (A) y fíjelas con 4 tuercas con reborde M6 (G).

7

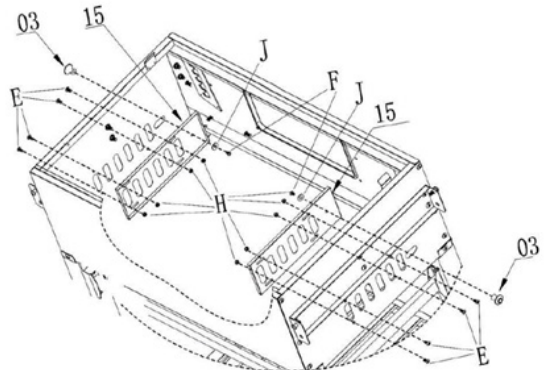

GUÍA DEL USUARIO

INSTRUCCIONES DE ENSAMBLAJE

8. Fije las escuadras inferiores (24) a la bandeja de carbón (15) con 4 tornillos M6 de 12 mm (A) y fíjelos con 4 tuercas con reborde M6 (G).

9. Conecte las escuadras superiores derecha (22) e izquierda (21) a la parte interior de los brazos inferiores (25) utilizando 2 ejes de bisagra M5 de 8 mm (N) y asegúrelos con una clavija (M).

10. A continuación, fije ambos brazos inferiores a la parte exterior de las escuadras inferiores (24) con 2 ejes de bisagra M5 de 8 mm (N) y asegure cada uno de ellos con una clavija (M).

11. Fije la barra elevadora (10) a las escuadras inferiores con 2 ejes de bisagra M5 de 8 mm (N) y asegure ambos con una clavija (M).

12. Introduzca la maneta (23) por el panel frontal del lado derecho y, a continuación, pásela por la compuerta cortafuegos (40) y la placa de ajuste de altura (41). A continuación, fíjela al panel trasero con un eje de bisagra M5 x 25 mm (P) y una clavija (M). Por último, fije el eje de bisagra M5 de 8 mm (N) a la rebaba de la compuerta cortafuegos y a la junta plana M6, y fíjelos con una clavija (M).

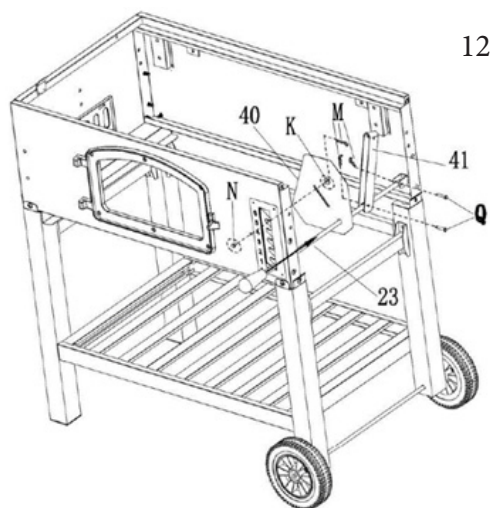
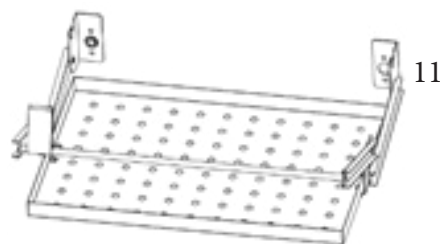
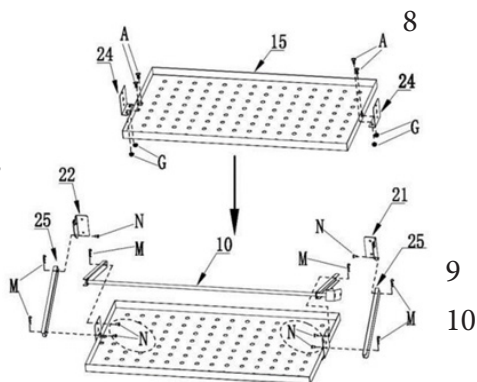

GUÍA DEL USUARIO

INSTRUCCIONES DE ENSAMBLAJE

13. Fije las escuadras superiores derecha e izquierda al panel frontal con 4 tornillos M5 de 12 mm (E). A continuación, coloque la barra elevadora (10) en las ranuras de las escuadras superiores izquierda y derecha (21,22).

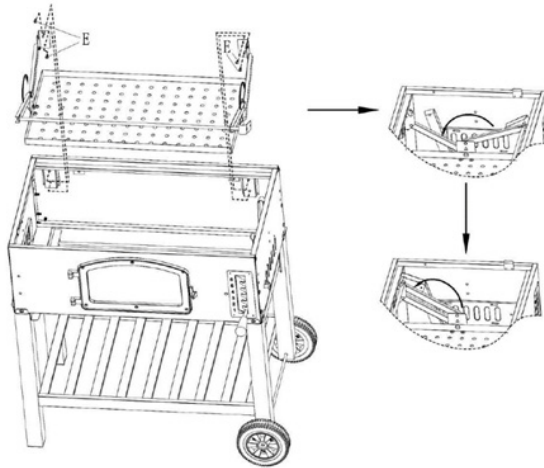

13

14. Fije el soporte de la maneta (42) a las escuadras superiores izquierda y derecha con 2 tornillos M4 de 10 mm (F). Ahora fije la placa de ajuste de altura (10) a la barra elevadora con un eje de bisagra M5 de 25 mm (P) y una clavija (M).

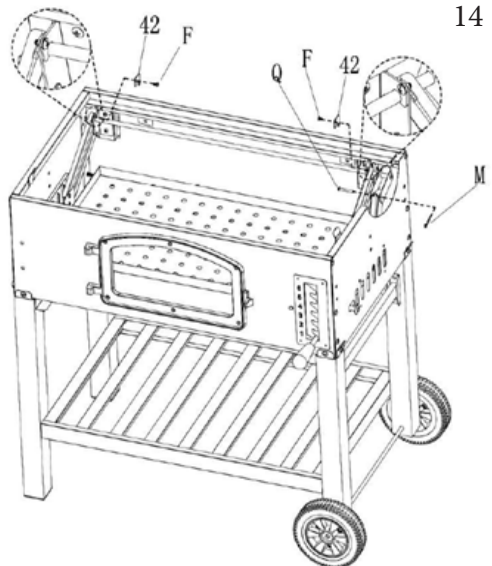

14

15. Ahora fije el abridor de botellas (6) al panel frontal con 2 tornillos M5 de 12 mm (E).

15

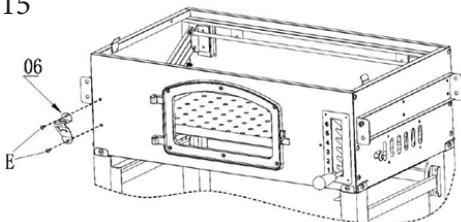

GUÍA DEL USUARIO

INSTRUCCIONES DE ENSAMBLAJE

16

16. Fije la puerta de hierro fundido (30) al panel frontal mediante 2 ejes de bisagra M5 de 45 mm (P) y fíjelos con clavijas (M).

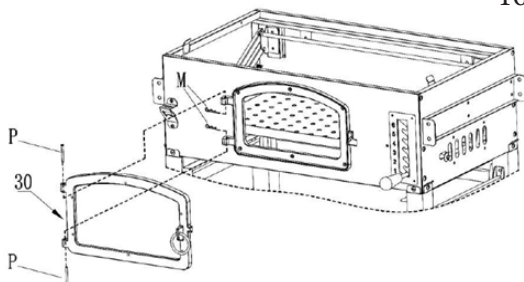

17. Ahora apoye el estante lateral izquierdo (13) y el estante lateral derecho (12) sobre los tornillos preinstalados (D) del paso 7. Fije ambos estantes laterales a los paneles laterales con 4 tornillos M6 de 18 mm (D). Fije las bisagras inferiores (20) al panel trasero con 4x tornillos M6 de 35mm (C) y asegúrelas con 4x tuercas con reborde M6 (G).

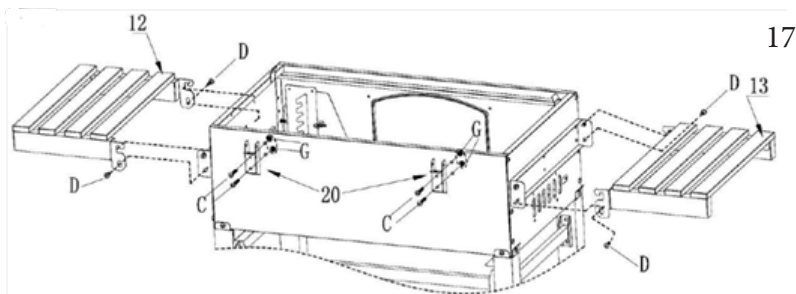

17

18. Fije el asa del cenicero (18) y la brida del asa del cenicero al cajón del cenicero (17) utilizando 2 juntas planas M6 (K) y 2 tornillos M6 de 20 mm (B).

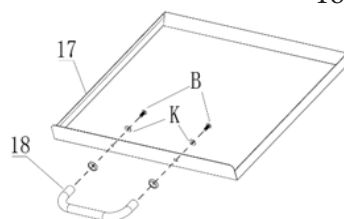

18

19

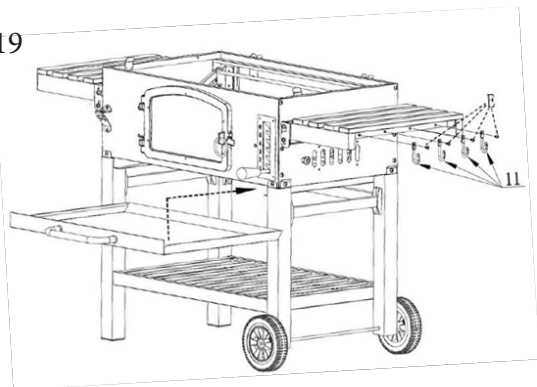

19. Deslice el cenicero por la parte delantera de la parrilla, justo debajo del panel frontal. A continuación, fije los ganchos laterales (11) al estante lateral derecho con 4 tornillos M5 de 12 mm (E).

GUÍA DEL USUARIO

INSTRUCCIONES DE ENSAMBLAJE

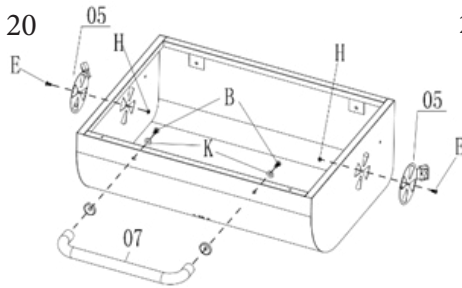

20. Para montar la tapa, fije el asa de la tapa (7) y la brida del asa de la tapa a la tapa de la parrilla (1) utilizando 2 juntas planas M6 (K) y 2 tornillos M6 de 20 mm (B). Fije las rejillas de ventilación de la tapa (5) a cada lado de la tapa con 2 tornillos M5 de 12 mm (E) y 2 tuercas con reborde M5 (H).

21. Fije las bisagras superiores (19) a la tapa de la barbacoa con 4 tornillos M6 de 35 mm (C) y 4 tuercas de brida M6 (G).

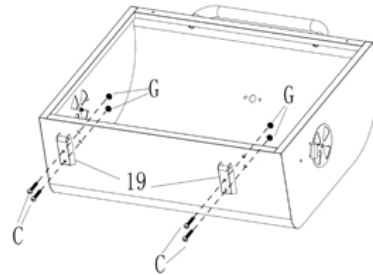

21

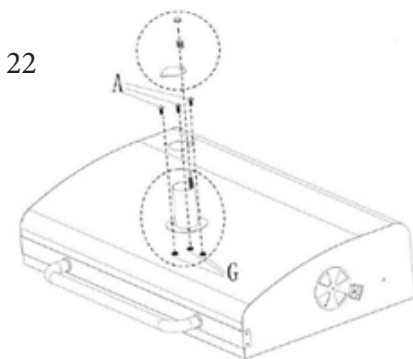

22

22. Es hora de fijar la chimenea a la tapa. Primero, quite la tapa de la chimenea, luego deslice la chimenea (2) hacia la tapa de la barbacoa desde el interior. Ahora fíjelas con 3 tornillos M6 de 12 mm (A) y 3 tuercas con reborde M6 (G). Vuelva a fijar la tapa de la chimenea en la chimenea con el muelle y la tuerca suministrados.

23. A continuación, coloque el indicador de temperatura (4) por el orificio de la tapa de la barbacoa y fíjelo con la tornillería suministrada.

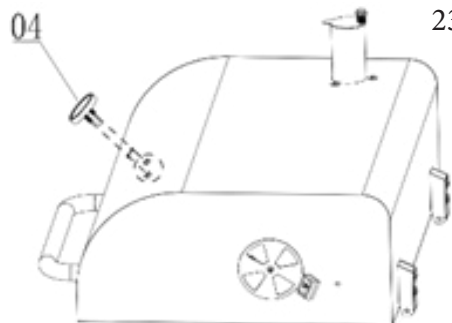

23

GUÍA DEL USUARIO

INSTRUCCIONES DE ENSAMBLAJE

24. Coloque la tapa de la barbacoa sobre el cuerpo de la misma, las bisagras superiores deben encajar dentro de las bisagras inferiores. Acople las bisagras entre sí utilizando 2 pasadores de bisagra M5 de 35 mm (O) y pasadores de clavija (M).

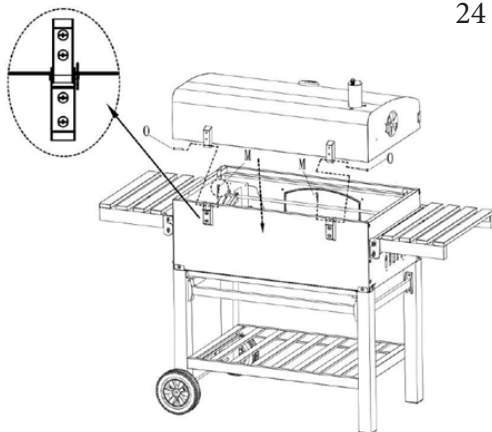

24

25. Encaje los lados izquierdo y derecho de la rejilla para calentar (8) en los soportes de la rejilla dentro de la tapa de la barbacoa y fíjela con clavijas (M). Coloque las parrillas (9) en el saliente superior del cuerpo de la parrilla. Ahora debería tener su Barbacoa con Parrilla y Ahumador completamente montada.

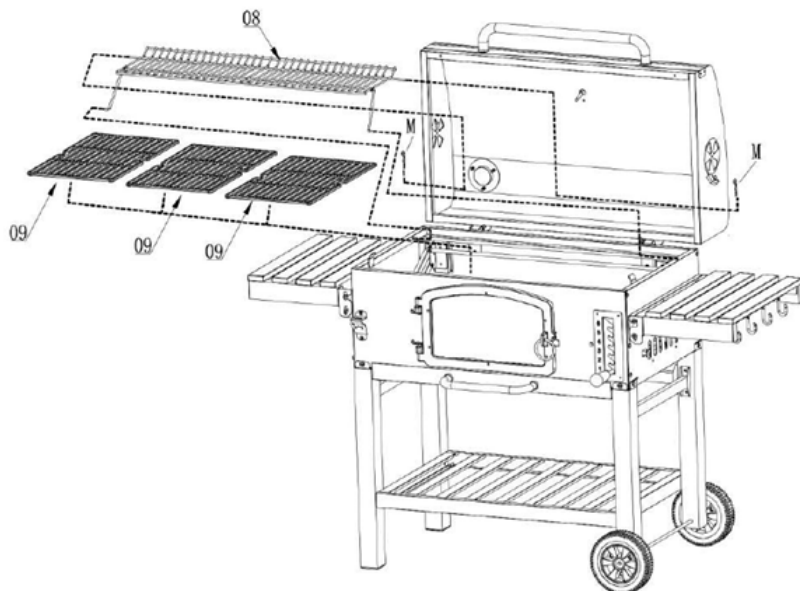

25

SOLUCIÓN DE PROBLEMAS

GUÍA DE RESOLUCIÓN

¿QUÉ PUEDO HACER SI LE FALTAN PIEZAS A MI PEDIDO?

Si parece faltar alguna pieza en su pedido, por favor, comuníquese con nuestro amable y servicial Equipo de Atención al Cliente en los 7 días posteriores a la recepción de su pedido.

¿CÓMO LIMPIO MI BARBACOA?

Le recomendamos que limpie el interior de su barbacoa tan pronto como sea seguro hacerlo utilizando una combinación de agua jabonosa caliente y el cepillo de alambre que le proporcionamos. Para el armazón, utilice sólo un paño suave y agua jabonosa caliente. Asegúrese de secarla bien antes de cubrirla con la cubierta suministrada.

**PARA CUALQUIER OTRO PROBLEMA, POR FAVOR CONTACTE
CON NUESTRO EQUIPO DE ATENCIÓN AL CLIENTE**

SPECIFICHE

DESCRIZIONE DEL PRODOTTO

Questo barbecue affumicatore Jardi è un'aggiunta ideale per il vostro cortile – non importa se siete appassionati occasionali o veri maestri della griglia – è lo strumento perfetto da aggiungere alle vostre attrezzature di cucina. Con un vassoio del carbone regolabile in 6 differenti altezze, soddisferete senza alcun dubbio le papille gustative di tutta la famiglia e degli amici.

SPECIFICHE DEL PRODOTTO



MATERIALE: Acciaio
DIMENSIONI: 111cm (A) x 142cm (L) x 62cm (P)
DIMENSIONI GRIGLIA: 77cm x 43.5cm
PESO: 34.5KG

ARTICOLI INCLUSI

- Vassoio del carbone con maniglia regolabile in 6 differenti altezze
- 2 Ripiani pieghevoli
- Termometro
- Spazzola metallica
- Copertura impermeabile

LISTA DEI PEZZI

Quando disimballerete per la prima volta il vostro barbecue affumicatore, controllate la presenza di ogni pezzo confrontandolo con questa lista per verificare che non manchi nulla. In tal caso, contattateci prima di iniziare ad assemblare.

N. del pezzo	Descrizione	Illustrazione	Quantità
1	Coperchio della griglia		X 1
2	Camino		X 1

SPECIFICHE

LISTA DEI PEZZI

3	Maniglie di ventilazione		X 2
4	Termometro		X 1
5	Prese d'aria del coperchio		X 2
6	Apribottiglie		X 1
7	Maniglia del coperchio		X 1
8	Rastrelliera di riscaldamento		X 1
9	Griglie di cottura in ghisa		X 3
10	Maniglie di sollevamento		X 1
11	Ganci		X 4
12	Ripiano laterale destro		X 1
13	Ripiano laterale sinistro		X 1
14	Barre di sostegno del pannello laterale		X 2

La responsabilità di Monster Group UK Limited sarà limitata al solo valore commerciale del prodotto.













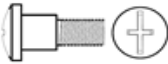



LISTA DEI PEZZI

15	Prese d'aria		X2
16	Vassoio della carbonella		X1
17	Contenitore per la cenere		X 1
18	Maniglia del cassetto della cenere		X 1
19	Cerniere superiori		X 2
20	Cerniere inferiori		X 2
21	Supporto superiore sinistro		X 1
22	Supporto superiore destro		X 1
23	Leva		X 1
24	Supporti inferiori		X 2
25	Bracci inferiori		X 2
26	Pannello laterale sinistro		X 1
27	Pannello posteriore		X 1
28	Pannello anteriore		X 1

LISTA DEI PEZZI

29	Pannello laterale destro		X 1
30	Porta in ghisa		X 1
31	Ruote		X 2
32	Asse		X 1
33	Gamba della ruota anteriore		X 1
34	Gamba della ruota posteriore		X 1
35	Gamba anteriore fissa		X 1
36	Gamba posteriore fissa		X 1
37	Pannello inferiore		X 1
38	Fascia posteriore del telaio		X 1
39	Fasce laterali del telaio		X 2
40	Serranda antincendio		X 1
41	Lastra per regolazione dell'altezza		X 1
42	Supporti della leva		X 2
A	Viti M6 12mm		X 59

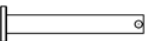
LISTA DEI PEZZI

B	Viti M6 20mm		X 4
C	Viti M6 35mm		X 8
D	Viti M6 18mm		X 8
E	Viti M5 12mm		X 20
F	Viti M4 10mm		X 4
G	Dadi flangiato M6		X 27
H	Dadi flangiato M5		X 10
I	Dadi di bloccaggio M8		X 2
J	Guarnizioni piatte M4		X 2
K	Guarnizioni piatte M6		X 5
L	Guarnizioni piatte M8		X 2
M	Coppiglie		X 16
N	Perni a cerniera M5 da 8 mm		X 7
O	Perni a cerniera M5 25 mm		X 2
P	Perni a cerniera M5 35mm		X 2
Q	Perni a cerniera M5 45mm		X 2

AVVISO DI SICUREZZA

PRASSI DI LAVORO SICURO

Si prega di leggere attentamente questa sezione per evitare lesioni e garantire l'assenza di danni alla griglia del barbecue affumicatore.

- Assicurarsi di aver letto attentamente e compreso il manuale di istruzioni e i consigli sulla sicurezza prima di iniziare ad assemblare il prodotto.
- Assicurarsi di montare e maneggiare il barbecue seguendo tali istruzioni.
- Non utilizzare mai questo prodotto per scopi diversi da quelli previsti.

POSIZIONAMENTO IN SICUREZZA DEL BARBECUE

- Utilizzare sempre questo prodotto all'aperto.
- Non utilizzare MAI il barbecue in uno spazio chiuso o sotto una zona coperta. La carbonella produce monossido di carbonio e quindi deve essere sempre bruciata in un'area dotata di ottima ventilazione.
- NON utilizzare questo barbecue a meno di 3 metri di qualsiasi materiale combustibile, inclusi arbusti, alberi, legno o legno trattato, recinzioni, patii, portici, muri, veicoli, benzina, gas per accendini o qualsiasi altro liquido infiammabile.
- Installare il barbecue SOLO su una superficie dura, piana, non combustibile e perfettamente stabile, come per esempio il cemento, in grado di sostenere il peso del barbecue stesso. Non utilizzare MAI su legno o su altre superfici combustibili.
- Non utilizzare MAI in luoghi dove i bambini o gli animali domestici possano entrare in contatto con il barbecue acceso.

PREPARAZIONE IN SICUREZZA DEL BARBECUE

- NON utilizzare il barbecue senza il relativo cassetto per la cenere.
- NON utilizzare il barbecue se non è stato completamente assemblato e se tutte le parti non sono in perfetto stato di funzionamento.

AVVISO DI SICUREZZA

PRASSI DI LAVORO SICURO

ACCENSIONE IN SICUREZZA DELLA CARBONELLA

- Raccomandiamo di utilizzare un liquido di avviamento per carbonella, in modo da evitare i pericoli del contatto con liquidi infiammabili. Leggere e seguire SEMPRE le istruzioni e le avvertenze del produttore, per evitare il verificarsi di gravi lesioni.
- Se si utilizza un liquido di avviamento della carbonella, utilizzarlo SOLO nel caso sia approvato e verificato per l'accensione del carbone.
- Non utilizzare MAI benzina, alcool, cherosene o qualsiasi altro liquido altamente infiammabile. L'uso di uno di questi prodotti o di prodotti simili potrebbe causare un'esplosione, e potrebbe causare gravi lesioni.
- Pulire SEMPRE qualsiasi perdita del liquido di avviamento prima di accendere la carbonella.
- Lasciar bruciare il liquido di avviamento COMPLETAMENTE prima di chiudere il coperchio del barbecue. In caso contrario, i fumi potrebbero rimanere intrappolati nel barbecue e provocare un incendio o un'esplosione quando il coperchio verrà aperto.
- Non aggiungere MAI il liquido di avviamento ai carboni ardenti o caldi. Potrebbero verificarsi delle fiammate improvvise, causa di eventuali ustioni.
- Conservare SEMPRE il liquido di avviamento in modo sicuro e lontano dal barbecue. NON conservare il liquido di avviamento o altri liquidi o materiali infiammabili sotto il barbecue.

SICUREZZA NELL'USO DELLA BARBECUE

- NON utilizzare il barbecue se sono presenti condizioni atmosferiche ventose.
- Non lasciare MAI incustodito un barbecue ancora caldo.
- Il barbecue è caldo quando è in uso. Per evitare bruciate:
 - o NON tentare di spostarlo mentre è acceso o ancora caldo.
 - o Indossare SEMPRE guanti protettivi o guanti da forno.
 - o NON TOCCARE le superfici calde del barbecue.

AVVISO DI SICUREZZA

PRASSI DI LAVORO SICURO

- NON indossare abiti larghi e non permettere ai capelli di entrare in contatto con il barbecue.
- Non aggiungere MAI carbone precedentemente imbevuto di liquido ai carboni ardenti o alla cenere. Potrebbero verificarsi fiammate pericolose, o esplosioni, con conseguenti danni fisici.
- PRESTARE ESTREMA ATTENZIONE quando si aggiunge carbone e/o legna al barbecue durante la cottura, poiché il carbone è ancora caldo e può causare ustioni.
- Aprire SEMPRE il coperchio per completo e fissarlo per evitare una chiusura improvvisa e indesiderata.
- Non andare MAI oltre i 3,6 kg di peso su nessuno dei ripiani. NON appoggiarsi a nessun ripiano.
- Non aggiungere MAI acqua durante l'affumicatura: l'acqua calda potrebbe schizzare sui carboni, creando uno scoppio di vapore e cenere calda.
- Quando si griglia, il grasso del cibo può gocciolare sulla carbonella e causare un incendio da grasso. Se dovesse accadere, chiudere il coperchio e le prese d'aria per soffocare la fiamma. Non utilizzare MAI acqua per spegnere un incendio di questo genere.
- Tenere le mani, il viso e il corpo a distanza di sicurezza dal barbecue quando si apre il coperchio. Quando le fiamme o i carboni ardenti hanno a disposizione un maggiore flusso d'aria, possono verificarsi delle fiammate.
- Non cercare MAI di rimuovere il cassetto della cenere mentre i carboni sono ancora caldi. Tale azione potrebbe causare ustioni.

SICUREZZA DOPO L'UTILIZZO

- Lasciare SEMPRE raffreddare completamente il barbecue e tutti i componenti prima di maneggiarli.
- Assicurarsi che il barbecue si sia completamente raffreddato prima di chiuderlo con l'apposito coperchio.

AVVISO DI SICUREZZA

PRASSI DI LAVORO SICURO

SICUREZZA DOPO L'UTILIZZO

- NON rimuovere la cenere o il carbone utilizzato all'interno del barbecue finché non sono completamente spenti e freddi.
- Per spegnere la brace, chiudere tutte le bocchette e il coperchio del barbecue il più a lungo possibile. Quando sarà necessario rimuoverle, trasferirle con cura in un contenitore di metallo non combustibile. Riempire con acqua e lasciare carbone e cenere nel contenitore di metallo per 24 ore, prima di smaltirli.
- Tenere le braci e la cenere spente lontane da strutture e materiali combustibili.
- Spruzzare o bagnare con acqua le superfici sotto e intorno al barbecue, fino a quando non saranno completamente bagnate, in modo da estinguere qualsiasi traccia di cenere, carbone o brace eventualmente cadute durante la cottura o la pulizia.
- Quando non viene utilizzato, conservare il barbecue in un luogo asciutto, fuori dalla portata dei bambini e degli animali domestici.

GUIDA ALL'USO

ISTRUZIONI PER IL MONTAGGIO

1. Verificate di avere tutte le parti necessarie per assemblare il barbecue.
2. Iniziate a fissare la gamba fissa anteriore (35), la gamba fissa posteriore (36) e le gambe delle ruote (33) (34) al pannello inferiore (37) usando 8 viti M6 da 12mm (A). Poi inserite l'asse (32) attraverso i fori delle gambe delle ruote (33) (34). Successivamente, posizionate le ruote (31) all'estremità di ciascun asse e fissate con la guarnizione piatta M8 (L) e i dadi di bloccaggio M8 (I).

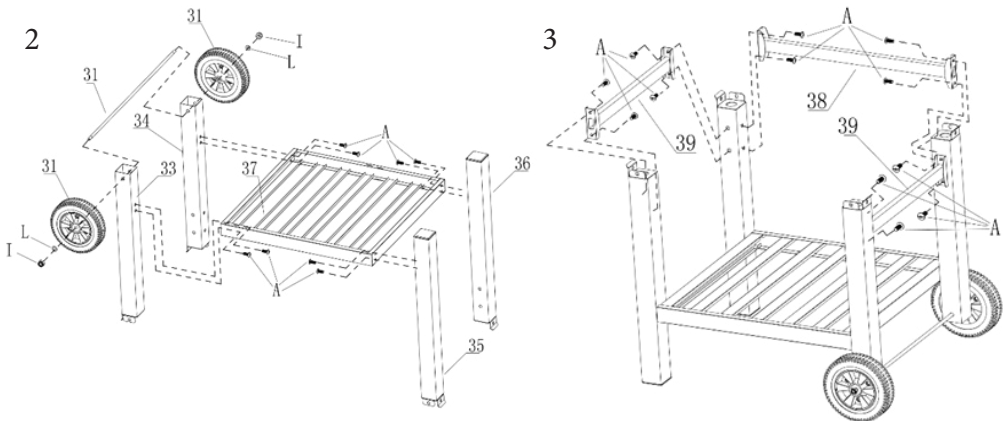

3. In seguito girate il telaio in modo che le ruote e i piedi siano a terra. Fissate quindi le fasce laterali del telaio (39) e la fascia posteriore del telaio (38) all'interno delle gambe con 12 viti M6 da 12mm (A).
4. Collegate ora il pannello laterale sinistro (26), il pannello posteriore (27), il pannello anteriore (28) e il pannello laterale destro (29) con 12 viti M6 da 12mm (A).

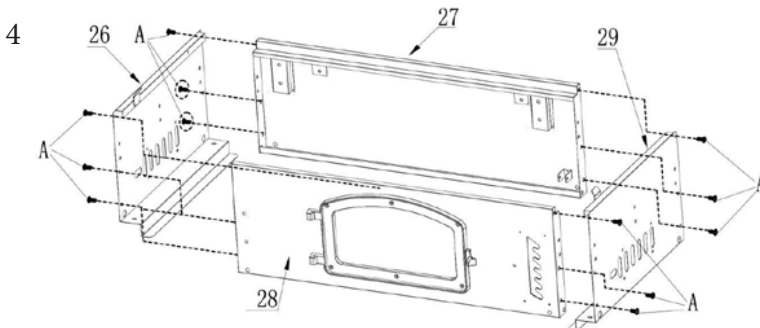

GUIDA ALL'USO

ISTRUZIONI PER IL MONTAGGIO

5. Fissate quindi il corpo del forno appena assemblato alle gambe della base (montata al punto 3) con 8 viti M6 da 12mm (A).

5

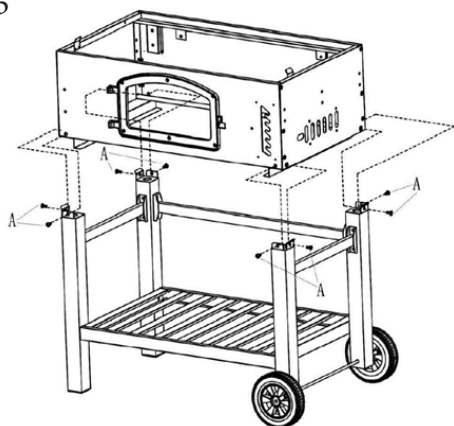

6

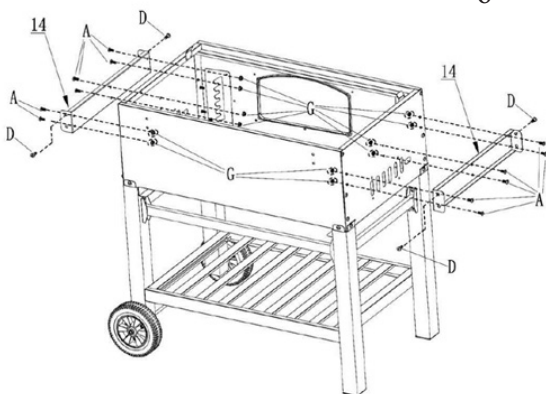

6. Collegate le due barre di sostegno del pannello laterale (14) ai due pannelli laterali con 12 viti M6 da 12mm (A), poi fissateli con 12 dadi flangiati M6 (G). Preinstallare 4 viti M6 da 18mm (D) alle barre di sostegno dei pannelli laterali (14).

7. Fissate ora le prese d'aria (15) ai due pannelli laterali con 8 viti M5 da 12mm (E) e bloccatele con 8 dadi flangiati M5 (H). Fissate le maniglie di ventilazione (3) alle prese d'aria (15) con le guarnizioni piatte M4 (J) e le viti M4 da 10mm (F).

7

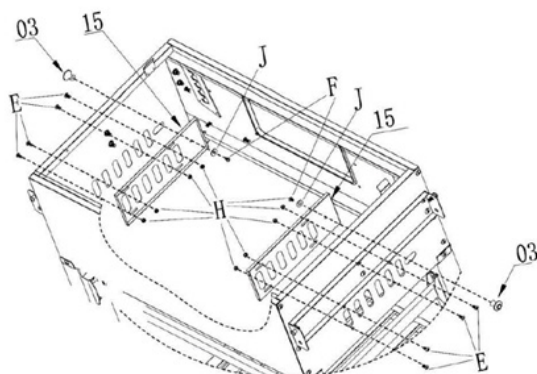

GUIDA ALL'USO

ISTRUZIONI PER IL MONTAGGIO

8. Fissate i supporti inferiori (24) al contenitore per la cenere (15) con 4 viti M6 da 12mm (A) e bloccatele con 4 dadi flangiati M6 (G).

9. Collegate il supporto superiore destro (22) e quello sinistro (21) all'interno dei bracci inferiori (25) utilizzando 2 perni a cerniera M5 da 8mm (N) e fissate entrambi con una coppia (M).

10. Quindi fissate entrambi i bracci inferiori all'esterno dei supporti inferiori (24) utilizzando 2 perni a cerniera M5 da 8mm (N) e poi fissate ciascuno di essi con una coppia (M).

11. Fissate le maniglie di sollevamento (10) ai supporti inferiori utilizzando 2 perni a cerniera M5 da 8mm (N) e bloccateli entrambi con una coppia (M).

12. Inserite la leva (23) attraverso il pannello anteriore sul lato destro, e poi fatela passare attraverso la serranda antincendio (40) e la piastra di regolazione dell'altezza (41). Quindi fissatela al pannello posteriore con un perno a cerniera M5 da 25mm (P) e una coppia (M). Ora fissate la piastra di regolazione dell'altezza (41) alla leva con un perno a cerniera M5 da 25mm (P) e una coppia (M). Infine, fissate un perno a cerniera M5 da 8mm (N) alla serranda antincendio e alla guarnizione piatta M6, bloccandoli con la coppia (M).

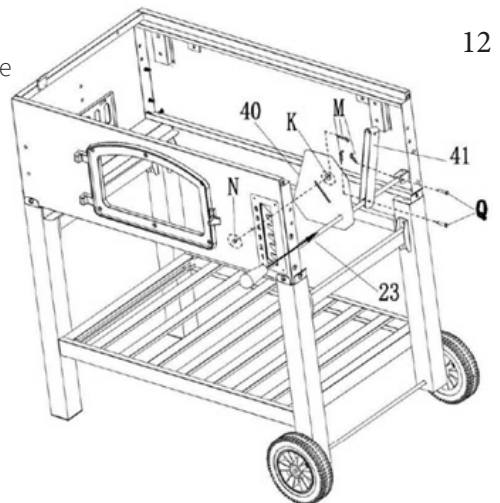
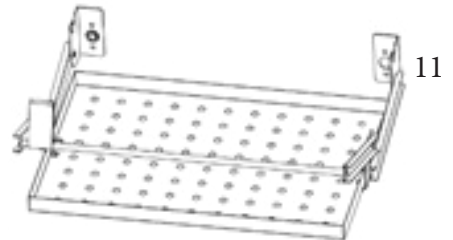
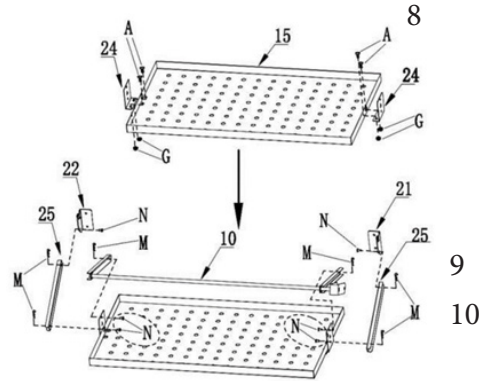

GUIDA ALL'USO

ISTRUZIONI PER IL MONTAGGIO

13. Fissate i supporti superiori destro e sinistro al pannello anteriore con 4 viti M5 da 12mm (E). Quindi fate scorrere le maniglie di sollevamento (10) nelle scanalature dei supporti superiori (21,22).

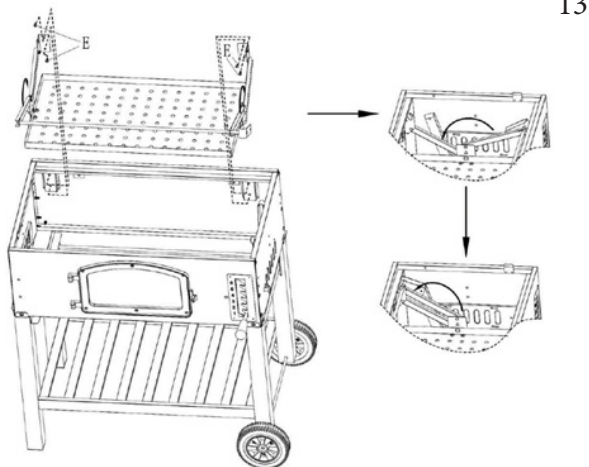

14. Fissate i supporti della leva (42) ai supporti superiori destro e sinistro con 2 viti M4 da 10mm (F). Ora fissate la piastra di regolazione dell'altezza (10) alle maniglie di sollevamento con un perno a cerniera M5 da 25mm (P) e una cinghia (M).

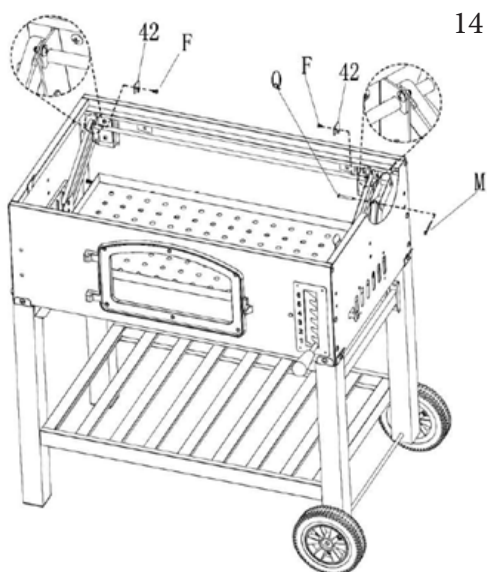

15. Ora fissate l'apribottiglie (6) al pannello frontale usando 2 viti M5 da 12mm (E).

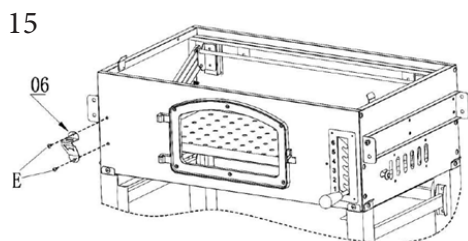

GUIDA ALL'USO

ISTRUZIONI PER IL MONTAGGIO

16

16. Fissate la porta in ghisa (30) al pannello frontale con 2 perni a cerniera M5 da 45mm (O) e bloccateli con 2 coppie (M).

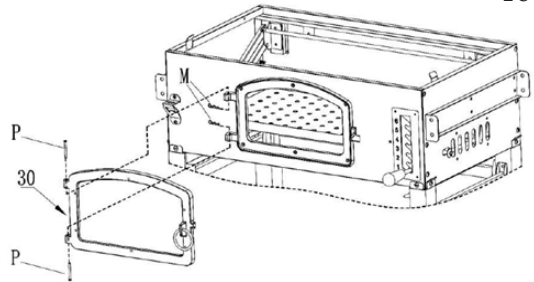

17. Ora fate scivolare il ripiano laterale sinistro (13) e quello destro (12) sulle viti preinstallate (D) al passo 6. Fissate entrambi i ripiani laterali ai pannelli laterali con 4 viti M6 da 18mm (D). Fissate poi le cerniere inferiori (20) al pannello posteriore con 4 viti M6 da 35mm (C) e bloccatele con 4 dadi flangiati M6 (G).

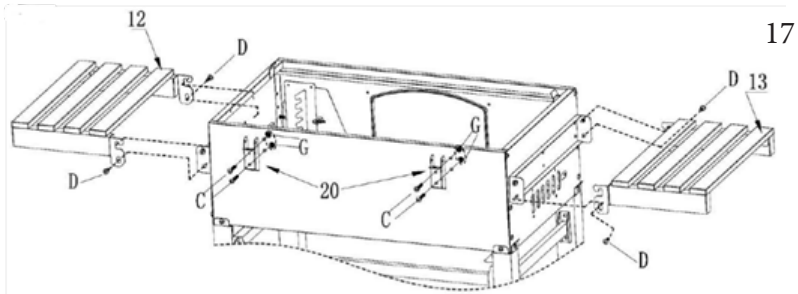

18

18. Fissate la maniglia del cassetto della cenere (18) e il relativo supporto al contenitore della cenere (17) utilizzando 2 guarnizioni piatte M6 (K) e 2 viti M6 da 20mm (B).

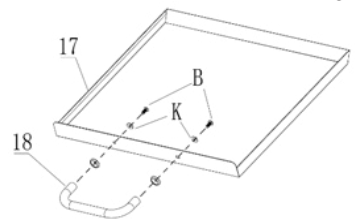

19

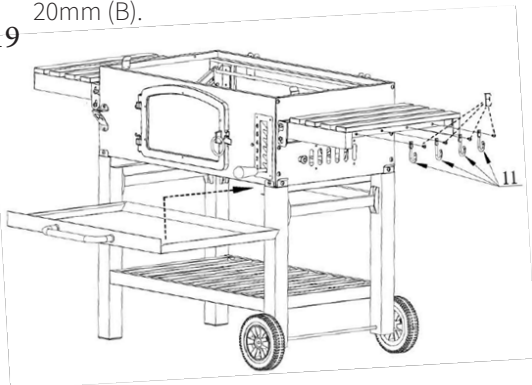

19. Fate scivolare il cassetto della cenere nella parte anteriore del barbecue, immediatamente sotto il pannello frontale. Quindi fissate i ganci (11) al ripiano laterale destro con 4 viti M5 da 12mm (E).

GUIDA ALL'USO

ISTRUZIONI PER IL MONTAGGIO

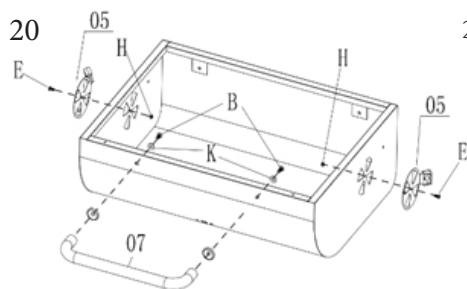

20. Per assemblare il coperchio, fissate la maniglia del coperchio (7) e il relativo supporto al coperchio del barbecue (1) utilizzando 2 guarnizioni piatte M6 (K) e 2 viti M6 da 20mm (B). Fissate le prese d'aria del coperchio (5) su entrambi i lati con 2 viti M5 da 12mm (E) e 2 dadi flangiati M5 (H).

21. Fissate le cerniere superiori (19) al coperchio del barbecue con 4 viti M6 da 35mm (C) e 4 dadi flangiati M6 (G).

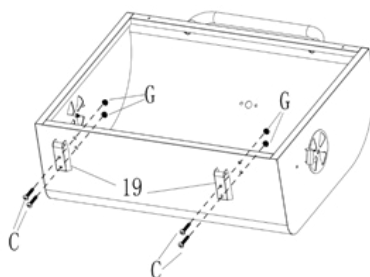

21

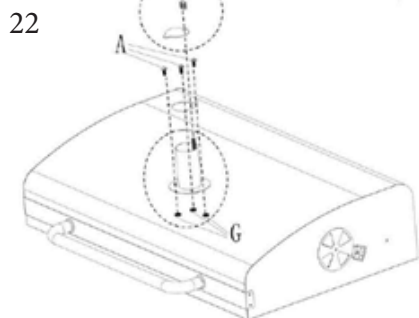

22. Ora fissate il camino al coperchio. Prima togliete il coperchio del camino, poi infilate il camino (2) nel coperchio del barbecue dall'interno. Ora fissatelo con 3 viti M6 da 12mm (A) e 3 dadi flangiati M6 (G). Fissate nuovamente il coperchio sulla canna fumaria stessa con la molla e il dado della canna fumaria in dotazione.

23. A questo punto posizionate il termometro (4) nel foro corrispondente sul coperchio del barbecue e fissatelo con i mezzi in dotazione.

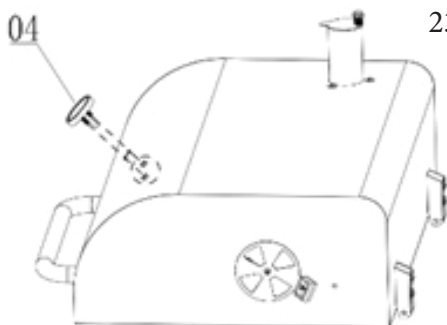

23

GUIDA ALL'USO

ISTRUZIONI PER IL MONTAGGIO

24. 24. Posizionate il coperchio del barbecue sopra la struttura: le cerniere superiori dovrebbero inserirsi all'interno delle cerniere inferiori. Collegatele assieme utilizzando 2 perni M5 da 35mm (Q) e 2 coppiglie (M).

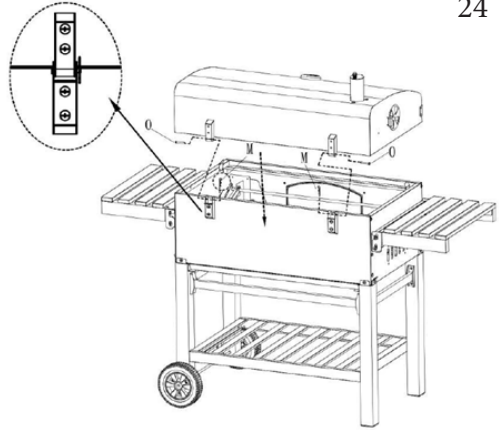

24

25. Inserite entrambi i lati della rastrelliera di riscaldamento (8) nei supporti presenti all'interno del coperchio del barbecue e fissateli con le coppiglie (M). Collocate le griglie di cottura in ghisa (9) sulla sporgenza superiore del barbecue. Ora dovrete avere il vostro barbecue affumicatore completamente assemblato e pronto per l'uso!

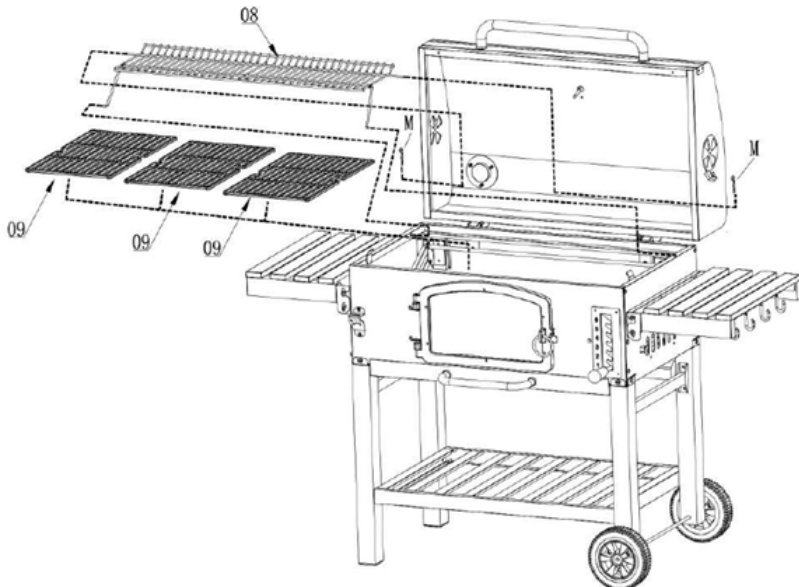

25

RISOLUZIONE DEI PROBLEMI

GUIDA DI RISOLUZIONE DEI PROBLEMI

COSA DEVO FARE SE MANCANO DEI PEZZI AL MIO ORDINE?

Se avete l'impressione che manchi qualche oggetto all'interno del vostro ordine, contattate il nostro amichevole e disponibile servizio di assistenza clienti entro 7 giorni dalla consegna del prodotto.

COME FACCIAMO A PULIRE IL MIO BARBECUE AFFUMICATORE?

Vi raccomandiamo di pulire l'interno del vostro barbecue, non appena è sicuro farlo, con una combinazione di acqua calda e sapone, utilizzando la spazzola metallica fornita in omaggio. Per il telaio, utilizzate solo un panno morbido con acqua calda e sapone. Assicuratevi di asciugarlo bene prima di proteggere il barbecue con la sua copertura impermeabile.

**PER QUALSIASI ALTRA PROBLEMATICHE, SI PREGA DI
CONTATTARE IL NOSTRO SERVIZIO DI ASSISTENZA CLIENTI**

SPEZIFIKATION

PRODUKTBEZEICHNUNG

Dieser Jardi BBQ Räuchergrill ist eine ideale Ergänzung für jeden Garten - egal ob Sie ein gelegentlicher Grillfan oder ein echter Grillmeister sind - dies ist das ultimative Gerät für Ihre Kochgeflugschaft. Mit der 6-fach höhenverstellbaren Kohlewanne können Sie sicher sein, dass Sie jeden Geschmack befriedigen können.

PRODUKTSPEZIFIKA



MATERIAL:	Stahl
ABMESSUNGEN:	111cm (H) x 142cm (B) x 62cm (T)
GRILLGRÖSSE:	77cm x 43,5cm
GEWICHT:	34.5KG

PRODUKTMERKMALE

- 6 höhenverstellbare Kohlewannen mit Griff
- 2 x klappbare Einlegeböden
- Temperaturanzeige
- Drahtbürste
- Wasserdichte Abdeckung











TEILELISTE

Wenn Sie Ihren BBQ-Räuchergrill zum ersten Mal auspacken, überprüfen Sie jedes Teil anhand dieser Liste, um sicherzustellen, dass sie alle vorhanden sind. Wenn etwas fehlt, kontaktieren Sie uns, bevor Sie versuchen den Grill zusammenzubauen.

Teil Nr.	Beschreibung	Abbildung	Menge
1	Grill-Deckel		X 1
2	Schornstein		X 1

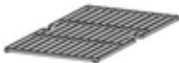
SPEZIFIKATION

TEILELISTE

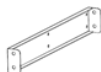













3	Griffe für Entlüftung		X 2
4	Temperaturmessgerät		X 1
5	Entlüftungsdeckel		X 2
6	Flaschenöffner		X 1
7	Griff des Deckels		X 1
8	Warmhaltegestell		X 1
9	Gusseisen-Kochroste		X 3
10	Liftgestell		X 1
11	Häkchen		X 4
12	Rechte Seitenablage		X 1
13	Linke Seitenablage		X 1
14	Seitenwandstützleiste		X 2

De aansprakelijkheid van Monster Group UK Limited is beperkt tot de commerciële waarde van het product.

TEILELISTE

15	Entlüftungsöffnungen		X2
16	Holzkohle-Tablett		X1
17	Eschenpfanne		X1
18	Eschenpfannen-Griff		X1
19	Obere Scharniere		X2
20	Untere Scharniere		X2
21	Linke obere Halterung		X1
22	Rechte obere Halterung		X1
23	Hebel		X1
24	Untere Klammern		X2
25	Arme		X2
26	Linke Seitenwand		X1
27	Rückwand		X1
28	Frontplatte		X1

TEILELISTE

29	Rechte Seitenwand		X 1
30	Tür aus Gusseisen		X 1
31	Räder		X 2
32	Achse		X 1
33	Vorderrad Bein		X 1
34	Hinterrad Bein		X 1
35	Vorderseite Standbein		X 1
36	Rückseite Standbein		X 1
37	Untere Platte		X 1
38	Rahmen Hinterer Träger		X 1
39	Rahmen Seitenträger		X 2
40	Brandschutzklappe		X 1
41	Höhenverstellbare Platte		X 1
42	Hebelstützbügel		X 2
A	M6 12mm Schraube		X 59

TEILELISTE

B	M6 20mm Schraube		X 4
C	M6 35mm Schraube		X 8
D	M6 18mm Schraube		X 8
E	M5 12mm Schraube		X 20
F	M4 10mm Schraube		X 4
G	M6 Flanschmutter		X 27
H	M5 Flanschmutter		X 10
I	M8 Sicherungsmutter		X 2
J	M4 Flachdichtung		X 2
K	M6 Flachdichtung		X 5
L	M8 Flachdichtung		X 2
M	Splint		X 16
N	M5 8mm Scharnierstift		X 7
O	M5 25mm Scharnierstift		X 2
P	M5 35mm Scharnierstift		X 2
Q	M5 45mm Scharnierstift		X 2

SICHERHEITSVORSCHLAG

SICHERE ARBEITSVERFAHREN

Bitte lesen Sie die Sicherheitshinweise durch, um Verletzungen oder Schäden am BBQ-Räuchergrill zu vermeiden.

- Vergewissern Sie sich, dass Sie die Gebrauchsanweisung und die Sicherheitshinweise gelesen und verstanden haben, bevor Sie das Produkt zusammenbauen.
- Achten Sie darauf, dass der Grill gemäß dieser Anleitung gehandhabt und zusammengebaut wird.
- Verwenden Sie dieses Produkt nicht für andere als die vorgesehenen Zwecke.

SICHERHEIT DER GRILLPLATZIERUNG

- Verwenden Sie den Grill immer im Freien.
- Benutzen Sie den Grill NIEMALS in einem geschlossenen Raum oder unter einer Überdachung. Holzkohle erzeugt Kohlenmonoxid und sollte daher immer in einem gut belüfteten Bereich verbrannt werden.
- Verwenden Sie diesen Grill NICHT in einem Umkreis von 3 m (10') von brennbarem Material, einschließlich, aber nicht beschränkt auf Sträucher, Bäume, Holz oder behandelte Holzdecks, Zäune, Terrassen, Veranden, Wände, Fahrzeuge, Benzin, Feuerzeugbenzin oder andere brennbare Flüssigkeiten.
- Verwenden Sie diesen Grill NUR auf einem harten, ebenen, nicht brennbaren, stabilen Untergrund, wie z. B. Beton, der das Gewicht des Grills tragen kann. NIEMALS auf Holz oder anderen brennbaren Oberflächen verwenden.
- Verwenden Sie diesen Grill NIEMALS dort, wo Kinder oder Haustiere mit dem Grill in Berührung kommen könnten.

SICHERHEIT BEI DER GRILLZUBEREITUNG

- Verwenden Sie den Grill NICHT ohne den Aschekasten.
- Benutzen Sie diesen Grill NICHT, wenn er nicht vollständig zusammengebaut ist und alle Teile nicht in Ordnung sind.

SICHERHEITSVORSCHLAG

SICHERE ARBEITSVERFAHREN

SICHERHEIT BEIM ANZÜNDEN VON HOLZKOHLE

- Wir empfehlen einen Holzkohle-Anzündkamin, um die Gefahren von Holzkohle-Anzündflüssigkeit zu vermeiden. Lesen und befolgen Sie IMMER die Anweisungen und Warnhinweise des Herstellers des Anzünders. Eine Nichtbeachtung kann zu schweren Verletzungen führen.
- Wenn Sie Anzündflüssigkeit für Holzkohle verwenden, verwenden Sie NUR Anzündflüssigkeit, die für das Anzünden von Holzkohle zugelassen ist.
- Verwenden Sie NIEMALS Benzin, Alkohol, Kerosin oder eine andere leicht entzündliche Flüssigkeit. Die Verwendung eines dieser oder ähnlicher Produkte kann zu einer Explosion führen, die schwere Verletzungen zur Folge haben kann.
- Säubern Sie vor dem Anzünden von Holzkohle IMMER die verschüttete Anzündflüssigkeit.
- Lassen Sie die Anzündflüssigkeit IMMER vollständig abbrennen, bevor Sie den Grilldeckel schließen. Andernfalls können sich Dämpfe im Grill festsetzen, die beim Öffnen des Deckels zu einem Flash-Brand oder einer Explosion führen können.
- Geben Sie NIEMALS Anzündflüssigkeit in heiße oder warme Kohlen. Es könnte zu einer Verpuffung kommen und Verbrennungen verursachen.
- Lagern Sie die Anzündflüssigkeit für Holzkohle IMMER in sicherer Entfernung vom Grill. Lagern Sie KEINE Anzündflüssigkeit oder andere brennbare Flüssigkeiten oder Materialien unter dem Grill.

SICHERHEIT BEIM GRILLEN

- Verwenden Sie den Grill NICHT bei Wind.
- Lassen Sie einen heißen Grill NIEMALS unbeaufsichtigt.
- Der Grill ist heiß, wenn er in Betrieb ist. Um Verbrennungen zu vermeiden:
 - o Versuchen Sie NICHT, den Grill zu bewegen, solange er noch heiß ist.
 - o Tragen Sie IMMER Schutzhandschuhe oder Ofenhandschuhe.
 - o Berühren Sie keine heißen Grillflächen.

SICHERHEITSVORSCHLAG

SICHERE ARBEITSVERFAHREN

- Tragen Sie KEINE weite Kleidung und lassen Sie Ihre Haare nicht mit dem Grill in Berührung kommen.
- Fügen Sie NIEMALS vorgetränkte Holzkohle zu heißer oder warmer Kohle oder Asche hinzu. Es kann zu gefährlichen oder explosiven Verpuffungen kommen, die zu körperlichen Schäden führen können.
- Seien Sie äußerst vorsichtig, wenn Sie während des Grillens Holzkohle und/oder Holz nachlegen, da die Holzkohle noch heiß ist und Verbrennungen verursachen kann.
- Öffnen Sie den Deckel IMMER vollständig und sichern Sie ihn, um ein unerwartetes Schließen zu verhindern.
- Legen Sie NIEMALS mehr als 3,6 kg (8 lb) auf einen der Einlegeböden. Lehnen Sie sich NICHT an den Grill.
- Fügen Sie beim Räuchern NIEMALS Wasser hinzu, da heißes Wasser auf die Kohlen spritzen und einen Dampfstoß und heiße Asche verursachen kann.
- Beim Grillen kann Fett vom Grillgut auf die Holzkohle tropfen und einen Fettbrand verursachen. Schließen Sie in diesem Fall den Deckel und die Lüftungsschlitze, um die Flamme zu ersticken. Verwenden Sie NIEMALS Wasser, um einen Fettbrand zu löschen.
- Halten Sie Hände, Gesicht und Körper in sicherer Entfernung vom Grill, wenn Sie den Deckel öffnen. Wenn Flammen oder heiße Kohlen auf einen erhöhten Luftstrom treffen, kann es zu einer Verpuffung kommen.
- Versuchen Sie NIEMALS, den Aschekasten zu entfernen, solange die Kohlen heiß sind. Dies könnte zu Verbrennungen führen.

SICHERHEIT NACH GEBRAUCH

- Lasciare SEMPRE raffreddare completamente il barbecue e tutti i componenti prima di maneggiarli.
- Assicurarsi che il barbecue si sia completamente raffreddato prima di chiuderlo con l'apposito coperchio.

SICHERHEITSVORSCHLAG

PRASSI DI LAVORO SICURO

SICUREZZA DOPO L'UTILIZZO

- NON rimuovere la cenere o il carbone utilizzato all'interno del barbecue finché non sono completamente spenti e freddi.
- Per spegnere la brace, chiudere tutte le bocchette e il coperchio del barbecue il più a lungo possibile. Quando sarà necessario rimuoverle, trasferirle con cura in un contenitore di metallo non combustibile. Riempire con acqua e lasciare carbone e cenere nel contenitore di metallo per 24 ore, prima di smaltirli.
- Tenere le braci e la cenere spente lontane da strutture e materiali combustibili.
- Spruzzare o bagnare con acqua le superfici sotto e intorno al barbecue, fino a quando non saranno completamente bagnate, in modo da estinguere qualsiasi traccia di cenere, carbone o brace eventualmente cadute durante la cottura o la pulizia.
- Quando non viene utilizzato, conservare il barbecue in un luogo asciutto, fuori dalla portata dei bambini e degli animali domestici.

GUIDA ALL'USO

ISTRUZIONI PER IL MONTAGGIO

1. Verificate di avere tutte le parti necessarie per assemblare il barbecue.
2. Iniziate a fissare la gamba fissa anteriore (35), la gamba fissa posteriore (36) e le gambe delle ruote (33) (34) al pannello inferiore (37) usando 8 viti M6 da 12mm (A). Poi inserite l'asse (32) attraverso i fori delle gambe delle ruote (33) (34). Successivamente, posizionate le ruote (31) all'estremità di ciascun asse e fissate con la guarnizione piatta M8 (L) e i dadi di bloccaggio M8 (I).

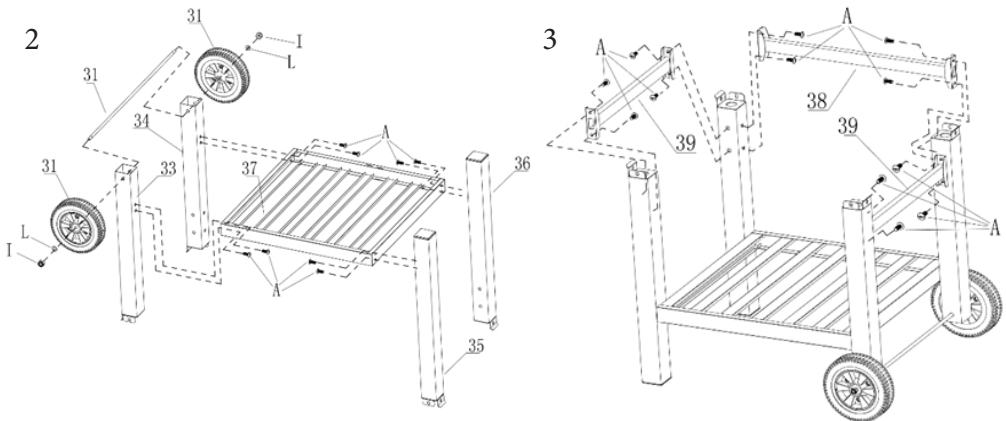

3. In seguito girate il telaio in modo che le ruote e i piedi siano a terra. Fissate quindi le fasce laterali del telaio (39) e la fascia posteriore del telaio (38) all'interno delle gambe con 12 viti M6 da 12mm (A).
4. Collegate ora il pannello laterale sinistro (26), il pannello posteriore (27), il pannello anteriore (28) e il pannello laterale destro (29) con 12 viti M6 da 12mm (A).

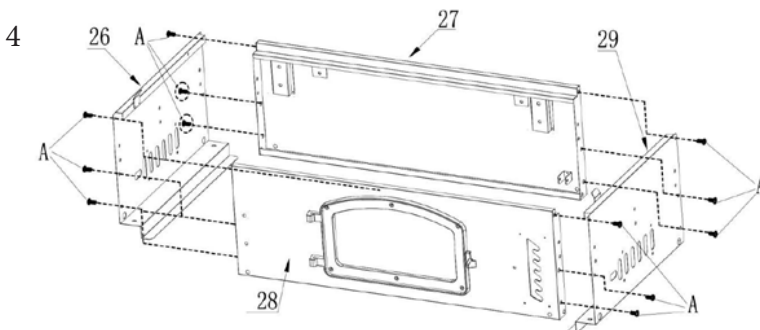

GUIDA ALL'USO

ISTRUZIONI PER IL MONTAGGIO

5. Fissate quindi il corpo del forno appena assemblato alle gambe della base (montata al punto 3) con 8 viti M6 da 12mm (A).

5

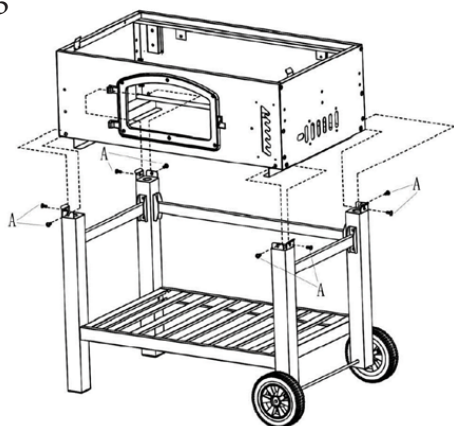

6

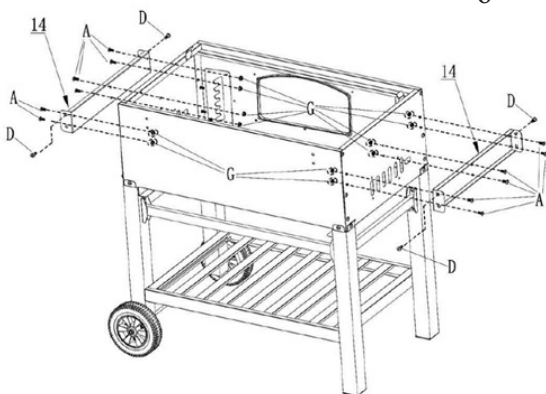

6. Collegate le due barre di sostegno del pannello laterale (14) ai due pannelli laterali con 12 viti M6 da 12mm (A), poi fissateli con 12 dadi flangiati M6 (G). Preinstallare 4 viti M6 da 18mm (D) alle barre di sostegno dei pannelli laterali (14).

7. Fissate ora le prese d'aria (15) ai due pannelli laterali con 8 viti M5 da 12mm (E) e bloccatele con 8 dadi flangiati M5 (H). Fissate le maniglie di ventilazione (3) alle prese d'aria (15) con le guarnizioni piatte M4 (J) e le viti M4 da 10mm (F).

7

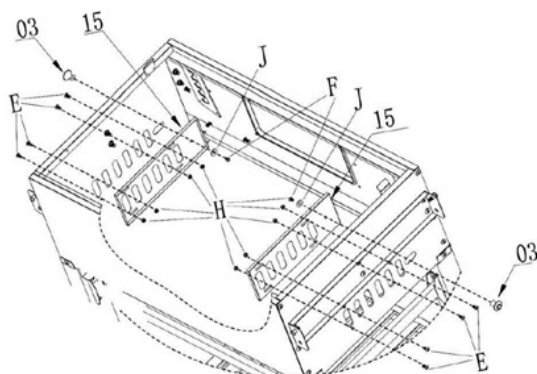

GUIDA ALL'USO

ISTRUZIONI PER IL MONTAGGIO

8. Fissate i supporti inferiori (24) al contenitore per la cenere (15) con 4 viti M6 da 12mm (A) e bloccatele con 4 dadi flangiati M6 (G).

9. Collegate il supporto superiore destro (22) e quello sinistro (21) all'interno dei bracci inferiori (25) utilizzando 2 perni a cerniera M5 da 8mm (N) e fissate entrambi con una coppiglia (M).

10. Quindi fissate entrambi i bracci inferiori all'esterno dei supporti inferiori (24) utilizzando 2 perni a cerniera M5 da 8mm (N) e poi fissate ciascuno di essi con una coppiglia (M).

11. Fissate le maniglie di sollevamento (10) ai supporti inferiori utilizzando 2 perni a cerniera M5 da 8mm (N) e bloccateli entrambi con una coppiglia (M).

12. Inserite la leva (23) attraverso il pannello anteriore sul lato destro, e poi fatela passare attraverso la serranda antincendio (40) e la piastra di regolazione dell'altezza (41). Quindi fissatela al pannello posteriore con un perno a cerniera M5 da 25mm (P) e una coppiglia (M). Ora fissate la piastra di regolazione dell'altezza (41) alla leva con un perno a cerniera M5 da 25mm (P) e una coppiglia (M). Infine, fissate un perno a cerniera M5 da 8mm (N) alla serranda antincendio e alla guarnizione piatta M6, bloccandoli con la coppiglia (M).

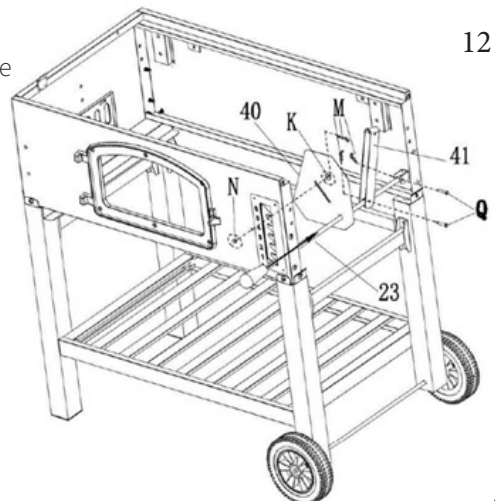
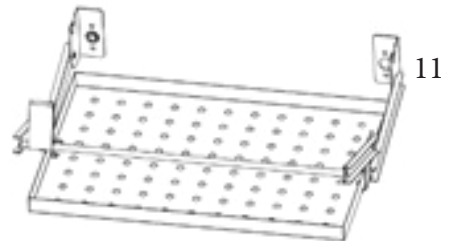
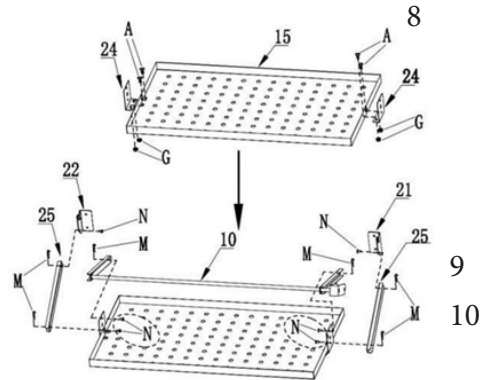

GUIDA ALL'USO

ISTRUZIONI PER IL MONTAGGIO

13. Fissate i supporti superiori destro e sinistro al pannello anteriore con 4 viti M5 da 12mm (E). Quindi fate scorrere le maniglie di sollevamento (10) nelle scanalature dei supporti superiori (21,22).

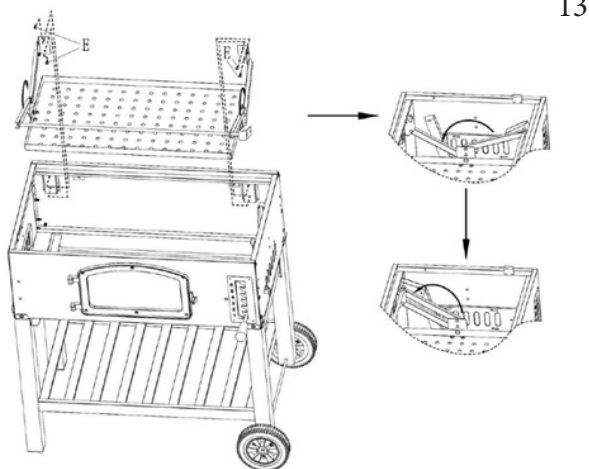

14. Fissate i supporti della leva (42) ai supporti superiori destro e sinistro con 2 viti M4 da 10mm (F). Ora fissate la piastra di regolazione dell'altezza (10) alle maniglie di sollevamento con un perno a cerniera M5 da 25mm (P) e una coppiglia (M).

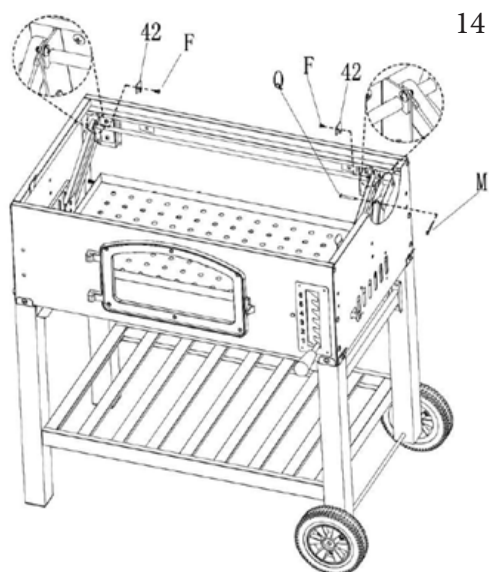

15. Ora fissate l'apribottiglie (6) al pannello frontale usando 2 viti M5 da 12mm (E).

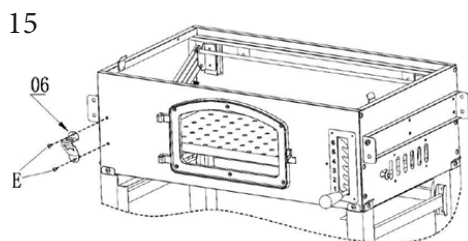

GUIDA ALL'USO

ISTRUZIONI PER IL MONTAGGIO

16

16. Fissate la porta in ghisa (30) al pannello frontale con 2 perni a cerniera M5 da 45mm (O) e bloccateli con 2 coppie (M).

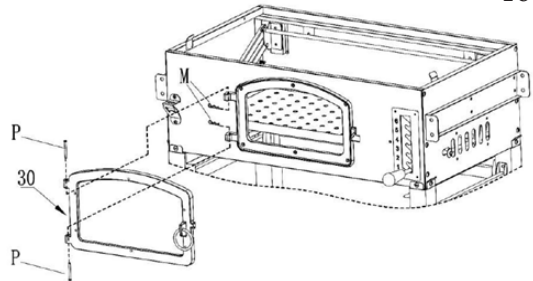

17. Ora fate scivolare il ripiano laterale sinistro (13) e quello destro (12) sulle viti preinstallate (D) al passo 6. Fissate entrambi i ripiani laterali ai pannelli laterali con 4 viti M6 da 18mm (D). Fissate poi le cerniere inferiori (20) al pannello posteriore con 4 viti M6 da 35mm (C) e bloccatele con 4 dadi flangiati M6 (G).

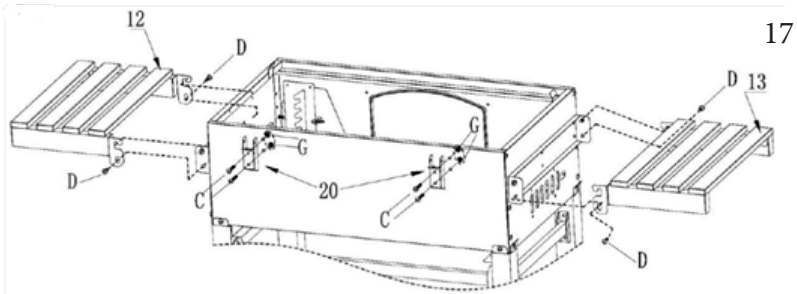

18. Fissate la maniglia del cassetto della cenere (18) e il relativo supporto al contenitore della cenere (17) utilizzando 2 guarnizioni piatte M6 (K) e 2 viti M6 da 20mm (B).

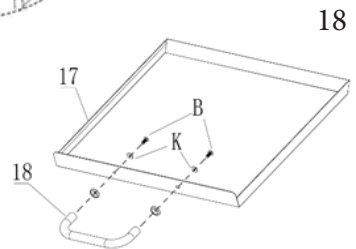

19

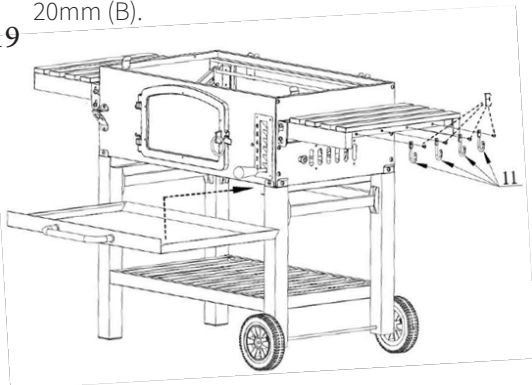

19. Fate scivolare il cassetto della cenere nella parte anteriore del barbecue, immediatamente sotto il pannello frontale. Quindi fissate i ganci (11) al ripiano laterale destro con 4 viti M5 da 12mm (E).

GUIDA ALL'USO

ISTRUZIONI PER IL MONTAGGIO

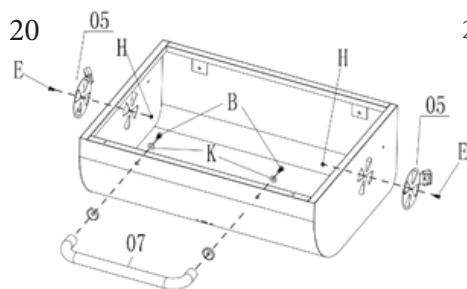

20. Per assemblare il coperchio, fissate la maniglia del coperchio (7) e il relativo supporto al coperchio del barbecue (1) utilizzando 2 guarnizioni piatte M6 (K) e 2 viti M6 da 20mm (B). Fissate le prese d'aria del coperchio (5) su entrambi i lati con 2 viti M5 da 12mm (E) e 2 dadi flangiati M5 (H).

21. Fissate le cerniere superiori (19) al coperchio del barbecue con 4 viti M6 da 35mm (C) e 4 dadi flangiati M6 (G).

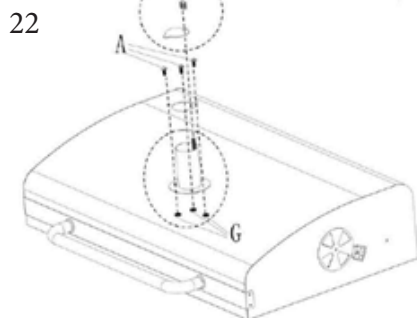
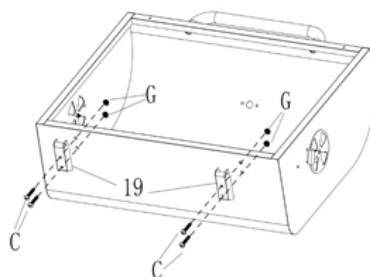

22. Ora fissate il camino al coperchio. Prima togliete il coperchio del camino, poi infilate il camino (2) nel coperchio del barbecue dall'interno. Ora fissatelo con 3 viti M6 da 12mm (A) e 3 dadi flangiati M6 (G). Fissate nuovamente il coperchio sulla canna fumaria stessa con la molla e il dado della canna fumaria in dotazione.

23. A questo punto posizionate il termometro (4) nel foro corrispondente sul coperchio del barbecue e fissatelo con i mezzi in dotazione.

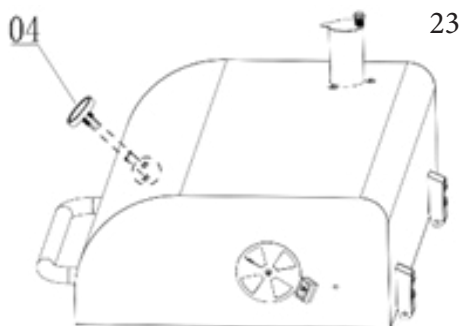

GUIDA ALL'USO

ISTRUZIONI PER IL MONTAGGIO

24. 24. Posizionate il coperchio del barbecue sopra la struttura: le cerniere superiori dovrebbero inserirsi all'interno delle cerniere inferiori. Collegatele assieme utilizzando 2 perni M5 da 35mm (Q) e 2 coppie (M).

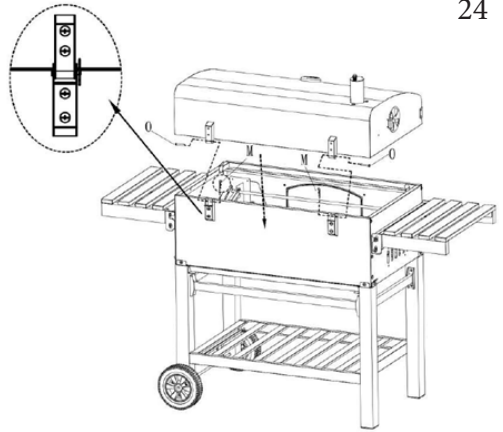

24

25. Inserite entrambi i lati della rastrelliera di riscaldamento (8) nei supporti presenti all'interno del coperchio del barbecue e fissateli con le coppie (M). Collocate le griglie di cottura in ghisa (9) sulla sporgenza superiore del barbecue. Ora dovrete avere il vostro barbecue affumicatore completamente assemblato e pronto per l'uso!

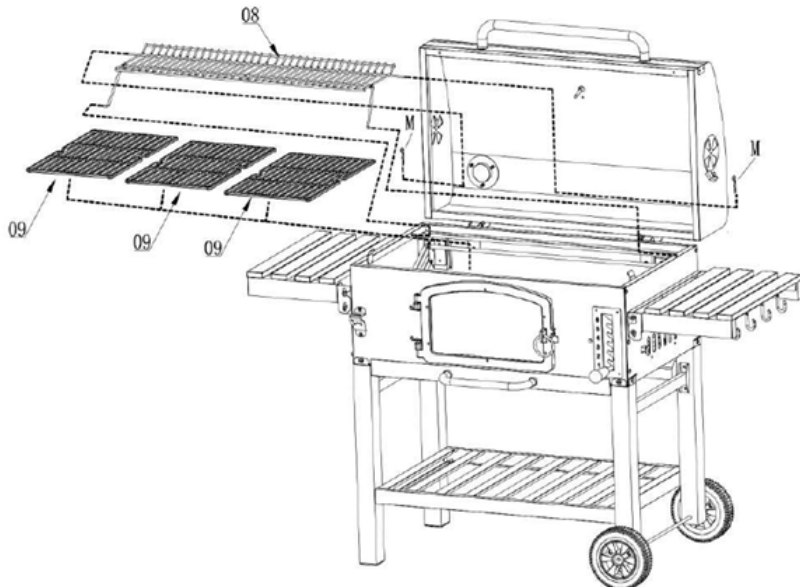

25

RISOLUZIONE DEI PROBLEMI

GUIDA DI RISOLUZIONE DEI PROBLEMI

COSA DEVO FARE SE MANCANO DEI PEZZI AL MIO ORDINE?

Se avete l'impressione che manchi qualche oggetto all'interno del vostro ordine, contattate il nostro amichevole e disponibile servizio di assistenza clienti entro 7 giorni dalla consegna del prodotto.

COME FACCIAMO A PULIRE IL MIO BARBECUE AFFUMICATORE?

Vi raccomandiamo di pulire l'interno del vostro barbecue, non appena è sicuro farlo, con una combinazione di acqua calda e sapone, utilizzando la spazzola metallica fornita in omaggio. Per il telaio, utilizzate solo un panno morbido con acqua calda e sapone. Assicuratevi di asciugarlo bene prima di proteggere il barbecue con la sua copertura impermeabile.

**PER QUALSIASI ALTRA PROBLEMATICHE, SI PREGA DI
CONTATTARE IL NOSTRO SERVIZIO DI ASSISTENZA CLIENTI**



SPECIFIKATION

PRODUKT BESKRIVNING

Denna rökgrill och BBQ från Jardi är ett utmärkt komplement till alla utomhuskök och trädgårdar - oavsett om du är en nybliven grillentusiast eller en riktig grillmästare är denna grill det ultimata verktyget i din samling. Kolbrickan kan justeras till 6 olika höjder så att du kan vara säker på perfekta resultat oavsett vad du lagar.

PRODUKTSPECIFIKATIONER

MATERIAL: Stål
DIMENSIONER: 111cm (H) x 142cm (B) x 62cm (D)
GRILLENS STORLEK: 77cm x 43,5cm
VIKT: 34,5KG

PRODUKTEGENSKAPER

- Kolbricka med handtag som kan justeras till 6 olika höjder
- 2 x upp- och nedfällbara hyllor
- Temperaturmätare
- Stålbörste
- Vattentätt skydd













MEDFÖLJANDE DELAR

När du packar upp din grill bör du kontrollera att alla delar i listan nedan är inkluderade i din leverans. Var god kontakta oss innan du påbörjar monteringen om något saknas.

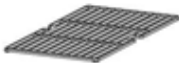
Artikelnummer	Beskrivning	Bild	Kvantitet
1	Lock för grill		X 1
2	Skorsten		X 1

SPEZIFIKATION

TEILELISTE

3	Handtag för ventil		X 2
4	Temperaturmätare		X 1
5	Lockventiler		X 2
6	Kapsylöppnare		X 1
7	Handtag för lock		X 1
8	Värmehylla		X 1
9	Grillgaller		X 3
10	Lyftställ		X 1
11	Krokar		X 4
12	Höger hylla		X 1
13	Vänster hylla		X 1
14	Sidopanel stödbalk		X 2

Monster Group UK Limiteds ansvar begränsas endast till produktens kommersiella värde.







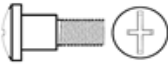

MEDFÖLJANDE DELAR

15	Luftventiler		X2
16	Kolbricka		X1
17	Askbricka		X1
18	Handtag för askbricka		X1
19	Övre gångjärn		X2
20	Nedre gångjärn		X2
21	Vänster övre fäste		X1
22	Höger övre fäste		X1
23	Spak		X1
24	Lägre fästen		X2
25	Nedre stänger		X2
26	Vänster sidopanel		X1
27	Bakre panel		X1
28	Frontpanel		X1

MEDFÖLJANDE DELAR

29	Höger sidopanel		X 1
30	Dörr i gjutjärn		X 1
31	Hjul		X 2
32	Axel		X 1
33	Framhjulsben		X 1
34	Bakhjulsben		X 1
35	Främre ben		X 1
36	Bakre ben		X 1
37	Bottenpanel		X 1
38	Ram för bakre balk		X 1
39	Ram för Sidobalk		X 2
40	Brandspjäll		X 1
41	Platta för höjjustering		X 1
42	Stödfäste för Spakarna		X 2
A	M6 12mm Skruv		X 59

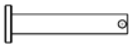
MEDFÖLJANDE DELAR

B	M6 20mm Skruv		X 4
C	M6 35mm Skruv		X 8
D	M6 18mm Skruv		X 8
E	M5 12mm Skruv		X 20
F	M4 10mm Skruv		X 4
G	M6 Flänsmutter		X 27
H	M5 Flänsmutter		X 10
I	M8 Låsmutter		X 2
J	M4 Mutterbricka		X 2
K	M6 Mutterbricka		X 5
L	M8 Mutterbricka		X 2
M	Saxsprint		X 16
N	M5 8mm Gångjärnsstift		X 7
O	M5 25mm Gångjärnsstift		X 2
P	M5 35mm Gångjärnsstift		X 2
Q	M5 45mm Gångjärnsstift		X 2

SÄKERHETSANVISNINGAR

SÄKER PRAXIS

Läs noga igenom säkerhetsanvisningarna för att undvika kroppsliga skador eller skadad produkt.

- Se till att du har läst och förstått bruksanvisningen och säkerhetsråden innan du monterar produkten.
- Se till att grillen hanteras och monteras enligt dessa anvisningar.
- Använd inte produkten för något annat än det avsedda ändamålet.

SÄKERHET VID PLACERING AV GRILLEN

- Använd alltid grillen utomhus.
- Använd ALDRIG grillen i ett slutet utrymme eller under ett täckt område. Kol skapar kolmonoxid och bör därför alltid brännas i ett välventilerat utrymme.
- Använd INTE grillen inom 3 meter från brännbart material, inklusive men inte begränsat till buskar, träd, träterrasser, staket, trägolv, verandor, väggar, fordon, bensin, tändvätska eller andra lättantändliga vätskor.
- Använd ENDAST grillen på en hård, jämn, eldsäker och stabil yta (t.ex. betong), som kan tåla grillens vikt. Använd ALDRIG grillen på trä eller andra brännbara ytor.
- Använd ALDRIG grillen där barn eller husdjur kan komma i kontakt med grillen.

FÖRBEREDANDE SÄKERHET

- Använd ENDAST grillen när askbrickan sitter på plats.
- Använd ENDAST grillen om den är fullständigt monterad och alla delar är i gott skick.

SÄKERHET VID TÄNDNING AV TRÄKOL

- Vi rekommenderar användning av skorstenständare för att undvika farorna med tändvätskor. Läs och följ ALLTID tillverkarens anvisningar och varningar för skorstenständaren. Försummelse av detta kan leda till allvarliga skador.

SÄKERHETSANVISNINGAR

SÄKER PRAXIS

- Om du använder tändvätska för träkol, använd ENDAST tändvätska som är framställd för att tända träkol.
- Använd ALDRIG bensin, alkohol, fotogen eller någon annan lättantändlig vätska. Användning av någon av dessa eller liknande produkter kan orsaka en explosion, vilket kan leda till allvarliga brännskador.
- Rengör ALLTID eventuellt spill av tändvätska innan du tänder kolet.
- Låt alltid tändvätskan brinna av helt innan du stänger grilllocket. Om du inte gör det kan rökgaserna stanna kvar i grillen, vilket kan leda till en brand eller explosion när locket öppnas.
- Tillsätt ALDRIG tändvätska till heta eller varma kol. Det kan resultera i flammor och orsaka brännskador.
- Förvara ALLTID tändvätskan på en säker plats borta från grillen. Förvara INTE tändvätskan eller andra lättantändliga vätskor/material under grillen.

SÄKERHET VID ANVÄNDNING AV GRILLEN

- Använd INTE grillen i blåsiga förhållanden.
- Lämna ALDRIG en varm grill obevakad.
- Grillen är varm när den används. För att undvika brännskador:
 - o Försök INTE flytta grillen när den är tänd eller fortfarande varm.
 - o Använd ALLTID skyddshandskar eller grytvantar.
 - o RÖR INTE de heta grillytorna.
- Bär INTE lösa kläder och låt inte håret komma i kontakt med grillen.
- Tillsätt ALDRIG snabbkol (förberedda med antändningsvätska) till hett eller varmt kol eller aska. Farliga och explosiva flammor kan uppstå och leda till brännskador.
- Var ytterst försiktig när du lägger kol och/eller ved i grillen under matlagning, eftersom kolet fortfarande är varmt och kan orsaka brännskador.

SÄKERHETSANVISNINGAR

SÄKER PRAXIS

- Öppna alltid locket helt och hållet och säkra det för att förhindra oväntad stängning.
- Placera ALDRIG mer än 3,6 kg på någon av hyllorna. Luta dig INTE mot någon hylla.
- Tillsätt ALDRIG vatten när du grillar, eftersom varmt vatten kan stänka på kolen och skapa ånga och het aska.
- När du grillar kan fett från maten droppa på kolet och orsaka en fettbrand. Om detta händer stänger du locket och luftventilerna för att kväva lågan. Använd ALDRIG vatten för att släcka en fettbrand.
- Håll händer, ansikte och kropp på ett säkert avstånd från grillen när du öppnar locket. Det kan uppstå eldsvådor när flammor eller heta kol möter ett ökat luftflöde.
- Försök ALDRIG att avlägsna askbrickan när kolen är heta. Det kan orsaka brännskador.

SÄKERHET EFTER ANVÄNDNING

- Låt ALLTID grillen och komponenterna svalna helt innan du hanterar dem.
- Se till att grillen har svalnat helt innan du täcker den med det grillens lock.
- Ta INTE bort aska eller förbrukat kol från grillen förrän det är helt släckt och kallt.
- För att släcka kolet stänger du alla ventiler och stänger grilllocket så länge som möjligt. När de måste tas avlägsnas, lägg dem försiktigt i en metallbehållare som inte kan antändas. Mätta kol och aska med vatten och låt dem ligga kvar i metallbehållaren i 24 timmar innan de kasseras.
- Förvara släckta kol och aska på säkert avstånd från brännbara konstruktioner och material.
- Spraya eller spruta vatten på ytorna under och runt grillen tills de är helt blöta för att släcka eventuell aska, kol eller glöd som kan ha fallit ner under grillningen eller rengöringen.
- Förvara grillen på ett torrt ställe utom räckhåll för barn och husdjur när den inte används.

BRUKSANVISNINGAR

MONTERINGSANVISNINGAR

1. Kontrollera att du har alla delar som behövs för att montera grillen.
2. Börja med att fästa det främre benet (35), det bakre benet (36) och hjulbenen (33) (34) på bottenpanelen (37) med hjälp av 8x M6 12mm skruvar (A). Sätt nu in axeln (31) genom hålen på hjulbenen (33) (34). Placera sedan hjulen (31) på ändan av varje axel och fäst dem med M8-mutterbrickor (L) och M8-låsmuttrar (I).

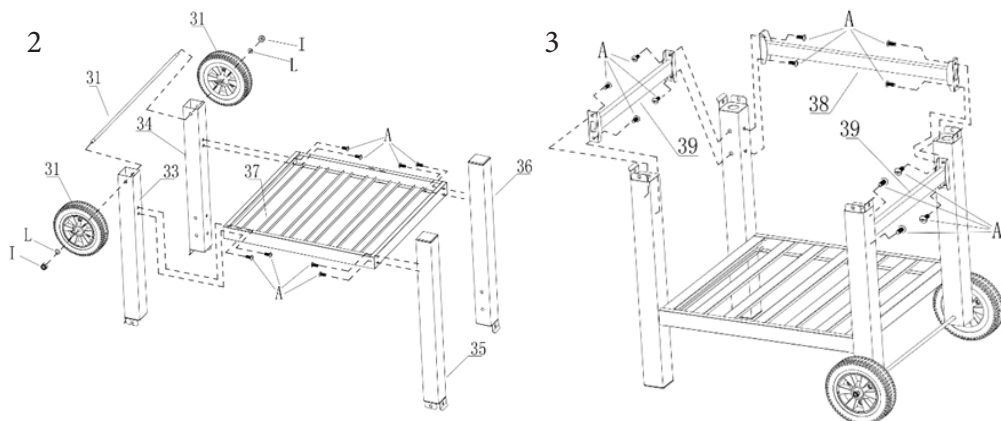

3. Vänd nu på ramen så att hjulen och fötterna står på marken. Fäst sedan ramens sidobalkar (39) och ramens bakre balk (38) på insidan av benen med 12x M6 12mm skruvar (A).
4. Anslut nu vänster sidopanel (26), bakre panel (27), främre panel (28) och höger sidopanel (29) med hjälp av 12x M6 12mm skruvar (A).

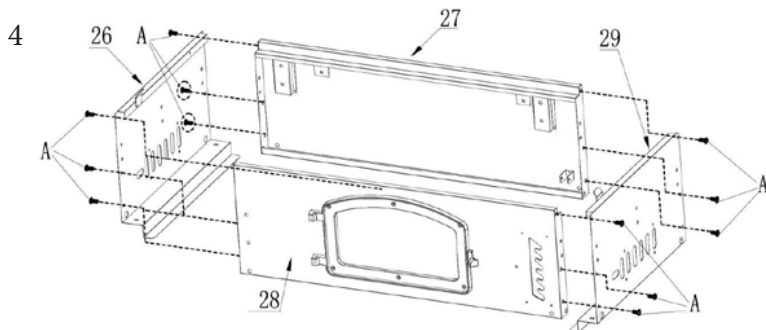

BRUKSANVISNINGAR

MONTERINGSANVISNINGAR

5. Fäst sedan grillhuset som du precis har monterat på benen på basen som monterades i steg 3 med 8x M6 12mm skruvar (A).

5

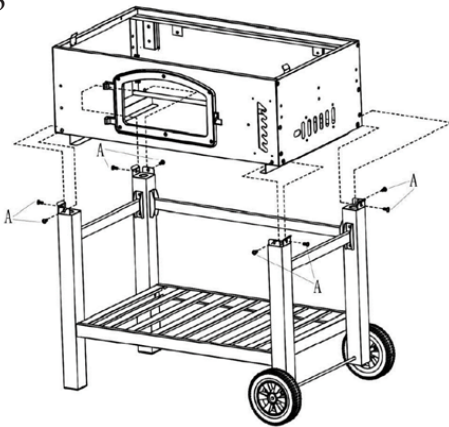

6

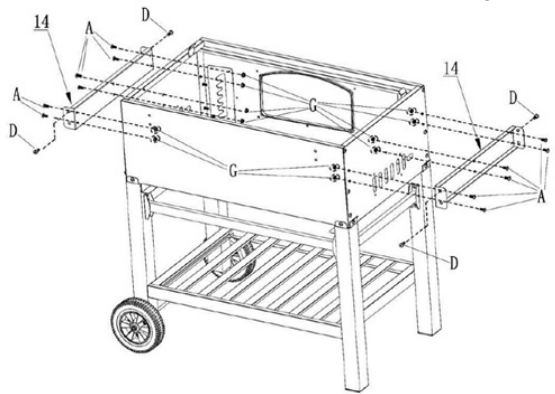

6. Ta de två sidopanelstöden (14) till de två sidopanelerna och fäst dem med 12x M6 12mm skruvar (A), fäst dem sedan med 12x M6 flänsmuttrar (G). Förmontera de 4x M6 18 mm skruvarna (D) på sidopanelstängerna (14).

7. Fäst nu luftventilerna (15) på de två sidopanelerna med 8x M5 12mm skruvar (E) och fäst dem med 8x M5 flänsmuttrar (H). Fäst ventilationshandtagen (3) på luftventilerna (15) med M4-mutterbrickor (J) och M4X10-skriv (F).

7

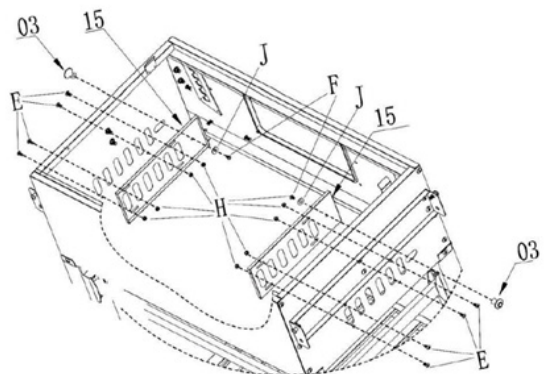

BRUKSANVISNINGAR

MONTERINGSANVISNINGAR

8. Sätt fast de nedre konsolerna (24) på kolbrickan (15) med 4x M6 12mm skruvar (A) och fäst dem med 4x M6 fläsmuttrar (G).

9. Anslut höger övre fäste (22) och vänster övre fäste (21) till insidan av de undre stängerna (25) med hjälp av 2x M5 8mm gångjärnsstift (N) och säkra båda med saxsprintar(M).

10. Sätt sedan fast de båda nedre stängerna på utsidan av de nedre konsolerna (24) med hjälp av 2x M5 8mm gångjärnsstift (N) och säkra dem båda med saxsprintar(M).

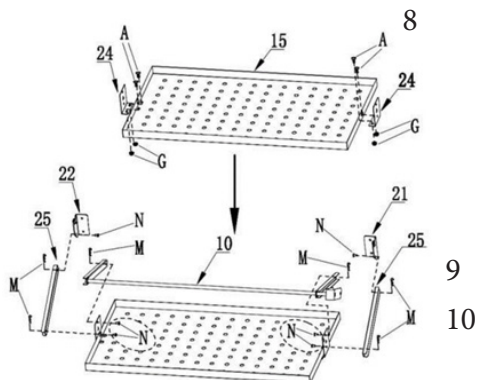

11. Sätt fast lyfthållaren(10) på de nedre fästena med 2x M5 8mm gångjärnsstift (N) och säkra dem båda med saxsprintar (M).

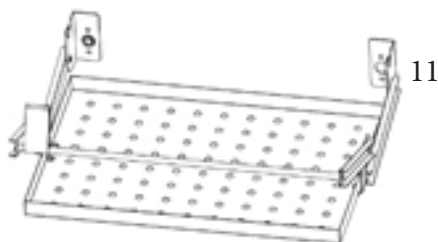

12. För in spaken (23) genom frontpanelen på höger sida och för den sedan genom både brandspjället (40) och den höga justeringsplattan (41). Fäst den sedan på bakpanelen med en M5 x 25 mm gångjärnsstift (P) och en saxsprint (M). Fäst nu den höga justeringsplattan (41) på spaken med en M5 25mm gångjärnsstift (P) och en saxsprint (M). Fäst slutligen fast M5 8mm gångjärnsstiftet (N) på brandspjällsskivan och M6 mutterbricka, och säkra dem med en saxsprint (M).

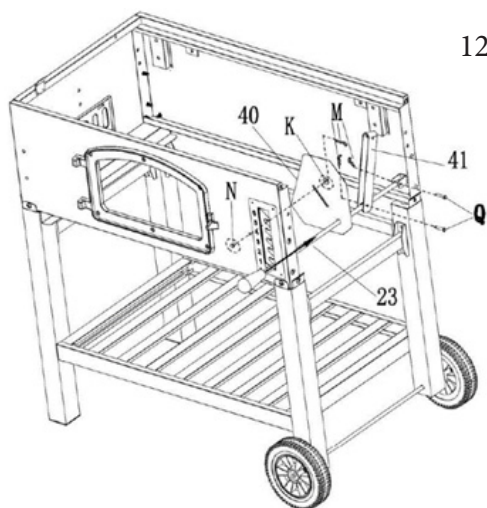

BRUKSANVISNINGAR

MONTERINGSANVISNINGAR

13. Fäst höger och vänster övre fäste på frontpanelen med 4x M5 12mm skruvar (E). Släpp sedan in lyfthållaren (10) i spåren i vänster och höger övre fäste (21,22).

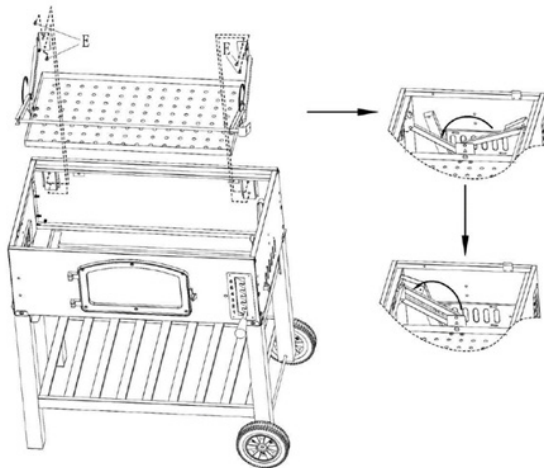

13

14. Fäst spakstödet (42) på vänster och höger övre fästen med 2 x M4 10mm skruvar (F). Sätt nu fast den höga justeringsplattan (10) på lyfthållaren med M5 25mm gångjärnsstift (P) och en saxsprint (M).

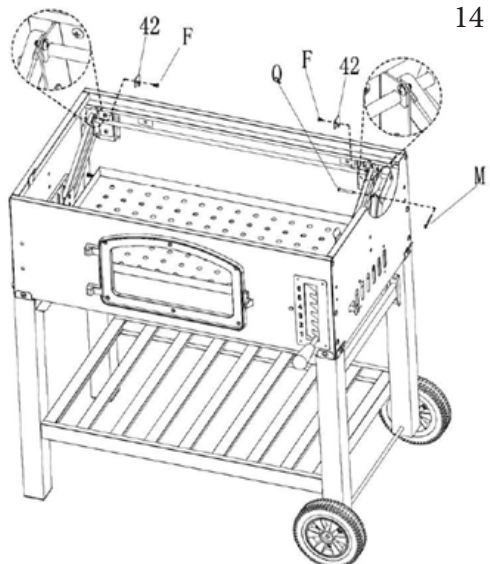

14

15. Fäst nu kapsylöppnaren (6) på frontpanelen med 2x M5 12mm skruvar (E).

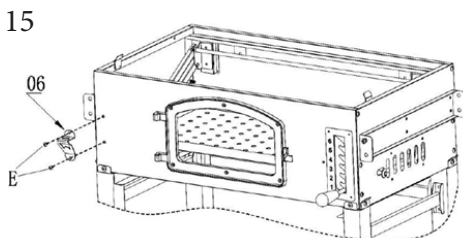

15

BRUKSANVISNINGAR

MONTERINGSANVISNINGAR

16. Fäst gjutjärnsdörren (30) på frontpanelen med 2x M5 45mm gångjärnsstift (O) och säkra dem med saxspindlar (M).

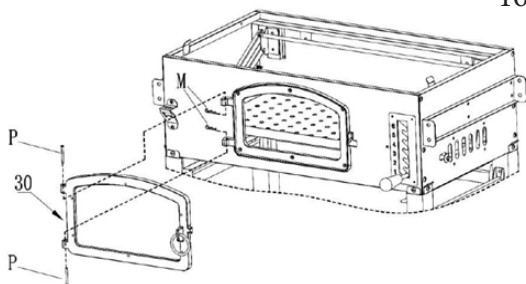

16

17. Släpp nu den vänstra sidohyllan (13) och den högra sidohyllan (12) på de förinstallerade skruvarna (D) från steg 6. Fäst båda sidohyllorna på sidopanelerna med 4x M6 18mm skruvar (D). Fäst de nedre gångjärnen (20) på bakpanelen med 4x M6 35mm skruvar (C) och säkra dem med 4x M6 flänsmuttrar (G).

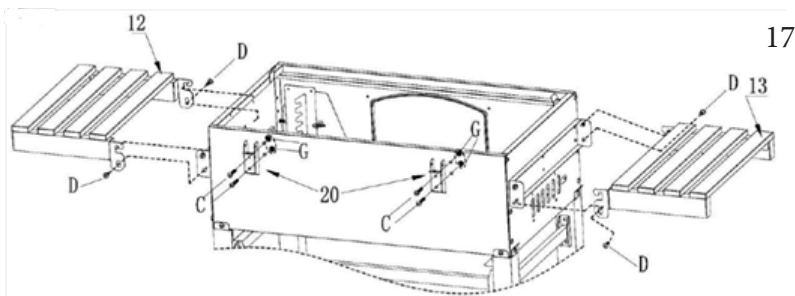

17

18. Fäst askhandtaget (18) och askhandtagsflänsen på askbrickan (17) med hjälp av 2x M6 mutterbrickor (K) och 2x M6 20 mm skruvar (B).

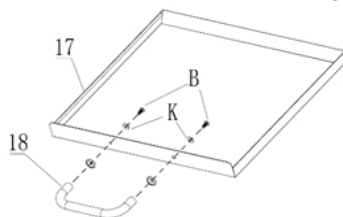

18

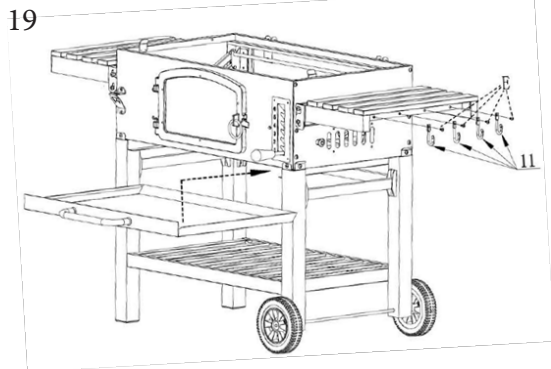

19. Skjut in askbrickan i grillens framsida, direkt under frontpanelen. Fäst sedan sidokrokarna (11) på höger sidohylla med 4x M5 12mm skruvar (E).

GUIDA ALL'USO

ISTRUZIONI PER IL MONTAGGIO

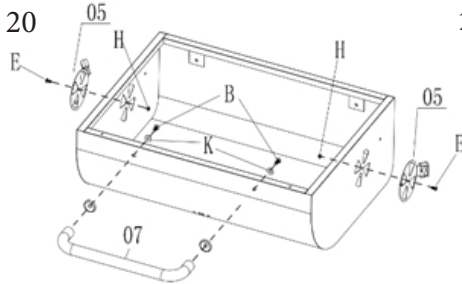

20. För att montera locket, fäst lockets handtag (7) och lockhandtagets fläns på grilllocket (1) med hjälp av 2x M6 mutterbricor (K) och 2x M6 20mm skruvar (B). Fäst lockventilerna (5) på vardera sidan av locket med 2x M5 12mm skruvar (E) och 2x M5 flänsmuttrar (H).

21. Fäst de övre gångjärnen (19) på grilllocket med 4x M6 35mm skruvar (C) och 4x M6 flänsmuttrar (G).

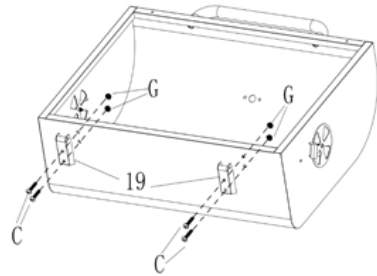

21

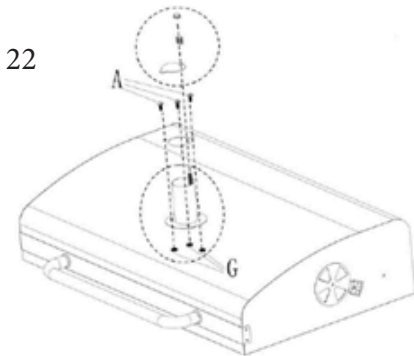

22. Nu ska du fästa skorstenen på locket. Ta först bort skorstenslocket och skjut sedan in skorstenen (2) i grilllocket från insidan. Fäst dem nu med 3x M6 12mm skruvar (A) och 3x M6 flänsmuttrar (G). Fäst skorstenslocket tillbaka på skorstenen med den medföljande fjädern och skorstensmuttern.

23. Placera sedan temperaturmätaren (4) genom hålet på grilllocket och fäst den med medföljande verktyg.

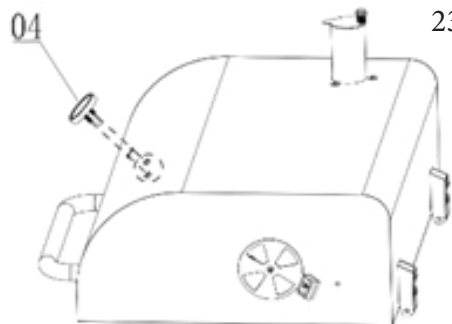

23

GUIDA ALL'USO

ISTRUZIONI PER IL MONTAGGIO

24. Placera grilllocket ovanpå grillhuset, de övre gångjärnen ska passa in i de nedre gångjärnen. Anslut gångjärnen till varandra med hjälp av 2x M5 35mm gångjärnsstift (Q) och kilar (M).

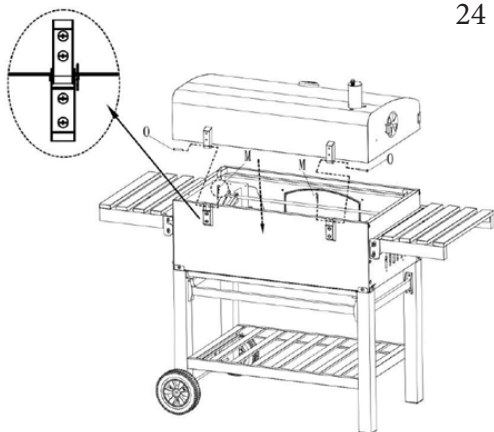

24

25. Fäst den vänstra och högra sidan av värmehyllan (8) i hållare på insidan av grilllocket och fäst det med saxsprintar (M). Placera gjutjärnsgallret (9) på den övre kanten av grillkroppen. Du bör nu ha din färdigmonterade BBQ rökgrill!

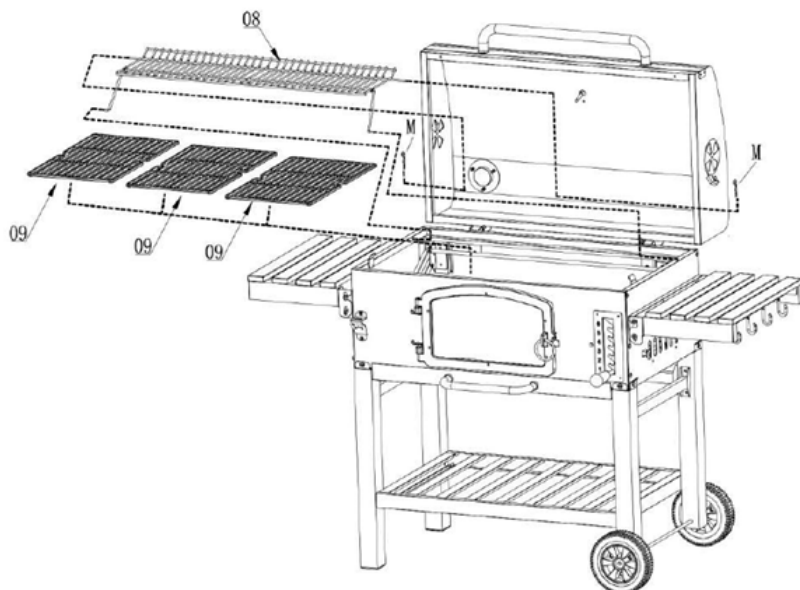

25

FELSÖKNING

GUIDE FÖR PROBLEMLÖSNINGAR

VAD GÖR JAG OM DET SAKNAS DELAR I MIN BESTÄLLNING?

Om det verkar saknas delar i din beställning, kontakta vår trevliga och hjälpsamma kundtjänst inom 7 dagar efter leverans.

HUR RENGÖR JAG MIN BBQ RÖKGRILL?

Vi rekommenderar att du rengör insidan av grillen så snart det är säkert att göra detta med en kombination av varmt tvålsvatten och stålborsten som inkluderas i din beställning. För ramen använder du endast en mjuk trasa och varmt tvålsvatten. Se till att torka den ordentligt innan du täcker den med det medföljande skyddet.

VÄNLIGEN KONTAKTA VÅR KUNDTJÄNST VID YTTERLIGARE FRÅGOR.



Monster Group (UK) is one of the UK's fastest growing online retailers. We supply a diverse range of products which offer exceptional value for money. We strive to provide the best possible customer experience with free UK delivery across all our products and a Monster Guarantee for 100% satisfaction.

For information regarding this device or other products from our Monster divisions please contact Sales.

SALES

TEL: 01347 878 888

EMAIL: hello@monstershop.co.uk

For queries about this device, warranty, returns or reporting faults please contact Support.

SUPPORT

TEL: 01347 878 887

EMAIL: help@monstershop.co.uk

Pour plus d'informations concernant cet appareil ou d'autres produits de nos divisions de Monster veuillez utiliser les détails suivants ci-dessous.

DÉPARTEMENT COMMERCIAL

TEL: 01347 878 888

EMAIL: bonjour@monstershop.eu

Pour les interrogations concernant cet appareil, la garantie, les retours ou les défauts de déclaration veuillez utiliser les détails suivants ci-dessous.

DÉPARTEMENT DE SOUTIEN

TEL: 01347 878 887

EMAIL: help@monstershop.co.uk

Para información sobre este dispositivo u otros productos de nuestras divisiones de Monster por favor use los siguientes detalles.

DEPARTAMENTO DE VENTAS

TEL: 01347 878 888

EMAIL: hola@monstershop.eu

Para consultas sobre este dispositivo, la garantía, devoluciones o denuncias de fallos por favor use los siguientes detalles.

DEPARTAMENTO DE SOPORTE

TEL: 01347 878 887

EMAIL: help@monstershop.co.uk

Für Informationen bezüglich dieses Geräts oder anderer Produkte aus unserer Monster-Abteilung, benutzen sie die folgenden unten aufgeführten Angaben.

VERKAUFABTEILUNG

TEL: 01347 878 888

EMAIL: hallo@monstershop.eu

Für Fragen über dieses Gerät, die Garantie, Rückgaben oder bei Störungen, benutzen sie die folgenden unten aufgeführten Angaben.

SUPPORT-ABTEILUNG

TEL: 01347 878 887

EMAIL: help@monstershop.co.uk

Per informazioni riguardanti questo dispositivo o altri prodotti dalle categorie Monster utilizzare i dettagli sotto riportati.

DIPARTIMENTO VENDITE

TEL: 01347 878 888

EMAIL: ciao@monstershop.eu

Per domande riguardo dispositivo, garanzia, reso o per riferire di guasti, utilizzare i dettagli sotto riportati.

DIPARTIMENTO SUPPORTO

TEL: 01347 878 887

EMAIL: help@monstershop.co.uk

Monster House, Alan Farnaby Way,
Sheriff Hutton Industrial Estate,
Sheriff Hutton, York, YO60 6PG
www.monstershop.co.uk



 Try **Monster**. Buy **Monster**. Be **Monster**. 