



Electric Inset Fireplace

29778 / 29779

INSTRUCTION MANUAL

www.monstershop.co.uk



SPECIFICATION

PRODUCT DESCRIPTION

Keep your home warm and stylish with the Electric Inset Fireplace. This fireplace, which features 12 LED flame colours with adjustable brightness, can be operated by remote control while the Child Safety Lock and a Safety Thermal Cut-Off gives you peace of mind.

With Pebbles, Crystal and Log effects, you can customise this fireplace to suit any room in your home. This Fireplace is designed to be mounted, inset into a wall or free-standing and fixings are included.

So, what are you waiting for – style and warmth are just moments away!

PRODUCT SPECIFICS

MODEL: 50" Model
DIMENSIONS: 48cm (H) x 127cm (W) x 13cm (D)
WEIGHT: 21KG

MODEL: 60" Model
DIMENSIONS: 48cm (H) x 152.4cm (W) x 15cm(D)
WEIGHT: 23KG

BOTH MODELS

MATERIAL: Metal & Toughened Glass
INPUT: AC 220-240V, 50Hz
OUTPUT: 1750-2000W
TEMPERATURE RANGE: 15°C - 36°C (60°F-97°F)

SPECIFICATION

ITEM CONTENTS

PART	QTY	DESCRIPTION
A	1 x	FIREPLACE
B	4 x	SCREWS
C	4 x	WALL PLUGS
D	1 x	DECORATIVE CRYSTAL SET
E	1 x	DECORATIVE LOG SET
G	1 x	DECORATIVE PEBBLES SET
F	1 x	REMOTE CONTROL

PRODUCT FEATURES

1. Front Glass Panel
2. LED Display and Touch Control Panel
3. Decorative Pebbles, Crystals or Log Set
4. Warm Air Vent

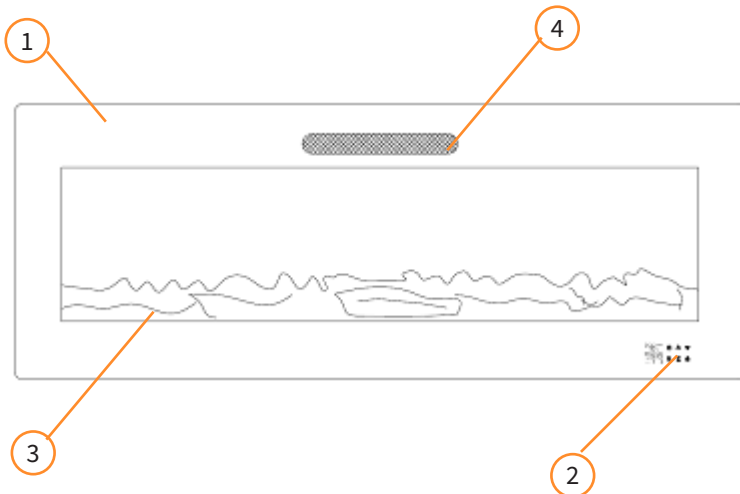

Monster Group UK Limited's liability will be limited to the commercial value of the product only.

SAFETY ADVICE

SAFE WORKING PRACTICE



CAUTION
RISK OF ELECTRIC SHOCK
DO NOT OPEN
NO USER-SERVICABLE PARTS INSIDE



Please read through the Safe Working Practice to ensure prevention of injury or damage to the device.

- **Do not attempt any repairs yourself. All repairs must be carried out by a qualified technician.**
- Do not use this appliance for anything other than its intended purposes.
- Ensure you have read and fully understood the instruction manual and safety advice before using this appliance.
- **CAUTION:** Some parts of this appliance can become very hot and cause burns. Particular attention must be given when children and vulnerable people are present.
- The appliance will get hot during use. Do not touch until the appliance has fully cooled off.
- The appliance must not be located immediately below a mains power socket.
- To prevent an inadvertent resetting of the Safety Thermal Cut-off, this appliance must NOT be connected to an external switching device, such as a timer.
- Do not operate this appliance around flammable liquids or materials.
- Do not put anything flammable into the appliance.
- Do not use in areas where petrol, paint or other flammable liquids are used or stored.
- Do not use this appliance outdoors.
- Ensure the electric cable is installed and routed so it is not likely to be pinched or walked on.
- The appliance includes a glass panel. Please handle with care when removing the panel to avoid injury or damage to the panel.

SAFETY ADVICE

SAFE WORKING PRACTICE

- Ensure children do not play with the appliance. Cleaning and maintenance should not be attempted by a child.
- Children of less than 3 years should be kept away unless continuously supervised.
- If the electric cable is damaged, it must be replaced by the manufacturer, its service agent, or similarly qualified persons to avoid potential injury.
- This appliance is not intended for use in bathrooms, laundry areas or similar indoor locations.
- Do not run cord under carpeting. Do not cover cord with throw rugs, runners, or similar coverings. Arrange cord away from traffic area and where it will not be tripped over.
- Do not insert or allow foreign objects to enter any ventilation or exhaust openings as this may cause an electric shock, a fire, or damage to the appliance.
- Do not obstruct air intake or exhaust vents.



USER GUIDE

INSTALLATION INSTRUCTIONS

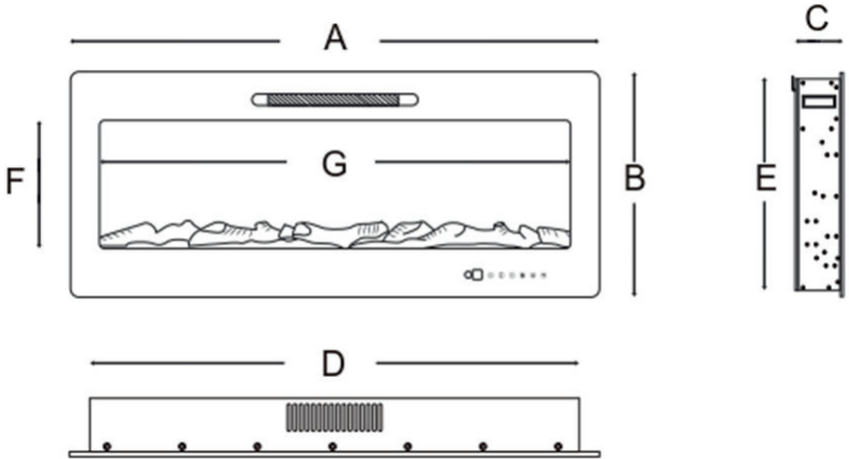
MODEL DIMENSIONS



MODEL	A	B	C	D	E	F	G
50"	127cm	48cm	13cm	118cm	45.5cm	27cm	110cm
60"	152.4cm	48cm	14.8cm	143.7cm	46cm	27cm	136.4cm

 MINIMUM CLEARANCE TO COMBUSTIBLES FOR BOTH MODELS 	
BOTTOM	0mm
SIDES	0mm
BACK	0mm
TOP	300mm

All measurements taken from the top of the fireplace.

USER GUIDE

1. Installation of the appliance should only be carried out by a Qualified Person.
2. Follow all National and Local electrical codes.
3. The following equipment will be required to install the Electric Fireplace (not included): Phillips Screwdriver, Spirit Level, Tape Measure, Electric Drill, 1/4" Drill Bit and a Hammer.

NOTE: A 10amp 230-240V AC Circuit is required. A dedicated circuit is recommended but not essential. If, after installation, the circuit breaker trips, or the fuse blows on a regular basis then a dedicated circuit will be required.

INSTALLING THE DECORATIVE CRYSTALS / PEBBLES / LOGS

1. Remove the fourth screw from the top down on both sides of the fireplace to remove the front glass panel.
2. Remove the Logs / Crystals and replace with the desired effect.
3. Replace the front glass panel.

INSET TO WALL INSTALLATION

1. Create hole in the wall. The size required is in the table below.
2. Drill 4 holes around the opening you have just made. The dimensions are below. Insert four wall plugs into these holes. **Ensure you note the minimum distances to combustibles before drilling the holes.**
3. Remove the 2 screws on the sides of the fireplace. (Fourth screw from top to bottom)
4. Remove the glass panel from the front of the fireplace and place in a soft, clean area.
5. Insert the fireplace (without glass front panel) into the hole and secure using the 4 screws provided.
6. Install your choice of decorative pebbles, crystals or logs into the fireplace.
7. Re-attach the glass front panel.

USER GUIDE

DIMENSIONS FOR INSET INTO WALL INSTALLATION

MODEL	FRAMING HOLE SIZE			DIMENSIONS FOR SCREW FITTINGS	
	WIDTH	HEIGHT	DEPTH	WIDTH	HEIGHT
50"	120.6cm	48.3cm	15cm	124.5cm	34.1cm
60"	145.29cm	48cm	15cm	146.8cm	34.1cm

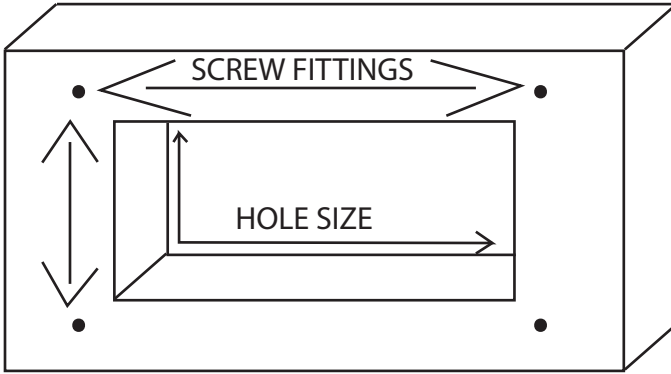

WALL MOUNTED INSTALLATION

1. There are hanging mounts on the rear of the appliance. Two on the 50" model and four on the 60" model. Measure and mark the positions of the mounts.
2. Drill two / four holes into the wall you are going to install the fireplace onto. Insert two / four wall plugs. **Ensure you note the minimum distances to combustibles before drilling the holes.**
3. Screw two / four screws into the wall plugs leaving 3-5mm exposed.
4. Now lift and hang the fireplace from the hanging mounts onto the exposed screws.





USER GUIDE

OPERATION INSTRUCTIONS

NOTE: The icons & functions on the touch control panel have the same icons & functions on the remote control.





When you first turn on the fireplace a slight odour may be present. This is normal and should not happen again unless the fireplace is not used for a long time.

When you first plug the fireplace into the mains you will hear a buzzer which indicates the fireplace is in standby mode. Press the Power symbol on the front display which will turn red. The fireplace will remain in standby mode.

BUTTON	FUNCTION
 POWER	<p>Press the power button to turn on the fireplace. There will be a short buzzer sound. The power button will turn blue on the display.</p> <p>Press the power button again to turn off the fireplace.</p>
 HEAT	<p>The fireplace default temperature is 22°C (72°F). If the room temperature is lower than the default temperature, then the fireplace will start in high heating mode. To adjust the fireplace to low heating mode, press the Heat button twice.</p> <p>The display will show the heating mode as follows:</p> <p>  One star indicates low heating mode. </p> <p>  Two stars indicates high heating mode. </p> <p>No stars indicates no heating mode.</p> <p>Pressing the Heat button for 3 seconds will change the display from Celsius to Fahrenheit.</p> <p>When the heating is turned off, the fan inside the fireplace will continue to work for 10 seconds.</p>
 TIMER	<p>The Timer can be set for between 0-12 hours.</p> <p>Once the fireplace is on press the timer button and the Temperature Display will change to a flashing '00'. Press the Timer button again to increase the time. The sequence is 00-30-1H-2H up to 12H in hour increments.</p>

USER GUIDE

OPERATION INSTRUCTIONS

BUTTON	FUNCTION
	Press to increase the temperature of the fire by 1°C increments.
	Press to decrease the temperature of the fire by 1°C increments.
	Flame brightness function. 5 settings of brightness. The fireplace will automatically start in the brightest mode.
	Press to change the flame colours. The default setting is orange. Each press will change to the next colour setting as follows – Orange, Green, Blue, White, Green & Orange, Orange & Blue, Orange & White, Green & Blue and Green & White.
	This Electric Fireplace has a child lock which can be accessed by pressing the up & down arrows together for 3 seconds on the display or the lock button on the remote for 1 second. An 'L' will appear on the display to confirm the lock is now on. To remove the child lock just press the up & down arrows together for 3 seconds on the display or the lock button on the remote for 1 second.
HOUR	Hour Setting – adjust the time by one hour.
MIN	Minute setting – adjust the time by one minute.
DAY	Day of week setting – press to adjust the day.
WEEK	Weekly timer setting.
SET-UP	Press to set up weekly timer function.

USER GUIDE

PLEASE NOTE - This fireplace has a thermostatic heater and therefore will only start to produce heat if the room temperature is lower than the temperature set on the fireplace.

Safety Thermal Cut-Off

This fireplace is fitted with the thermal safety cut-off. If the fireplace reaches an unsafe temperature, then the cut-off will automatically switch the fireplace off.

To reset:

1. Turn the on/off switch on the fireplace to off and unplug from the mains.
2. Wait 5 minutes and inspect the fireplace to make sure no vents are blocked. Clear any blockages.
3. Plug into mains and turn on with the power switch on the fireplace.
4. If the problem persists, contact customer services.

MAINTENANCE & CLEANING

Disconnect power before attempting any maintenance or cleaning to reduce the risk of fire, electric shock, or injury.

Apart from lightbulb replacement and cleaning, an authorised, qualified service technician should perform all other servicing.

Glass – Use a quality glass cleaner and dry thoroughly with a paper towel or lint free cloth. Never use abrasive cleaners or liquid sprays.

Metal – Buff using a soft cloth. Do not use brass polish or an abrasive cleaner.

TROUBLESHOOTING

RESOLUTION GUIDE

WHAT DO I DO IF THERE ARE MISSING PARTS FROM MY ORDER?

If there appears to be any part missing from your order, contact our friendly and helpful Customer Support Team within 7 days of receipt.

WHY ISN'T MY FIREPLACE TURNING THE HEATER ON?

As your fireplace has a built-in thermostat, it will only start to produce heat when the temperature you set is higher than the current room temperature. Check that you have set the temperature high enough for the heater to switch on.

**FOR ALL OTHER ISSUES, PLEASE CONTACT OUR
CUSTOMER SUPPORT TEAM.**



SPÉCIFICATIONS

DESCRIPTION DU PRODUIT

DÉTAILS DU PRODUIT

LISTE DES PIÈCES

SPÉCIFICATIONS

CARACTÉRISTIQUES DU PRODUIT

La responsabilité de Monster Group UK Limited sera limitée à la valeur commerciale du produit.

CONSEILS DE SÉCURITÉ

 PRATIQUE DE TRAVAIL SÉCURITAIRE

MODE D'EMPLOI

INSTRUCTIONS DE MONTAGE

MODE D'EMPLOI

ENTRETIEN

DÉPANNAGE

GUIDE DE RÉOLUTION

QUE FAIRE S'IL MANQUE DES PIÈCES À MA COMMANDE?

S'il semble manquer des pièces à votre commande, contactez notre équipe du service client dans les 7 jours suivant la réception.

**POUR TOUT AUTRE PROBLÈME, VEUILLEZ
CONTACTER NOTRE ÉQUIPE DU SERVICE CLIENT.**



SPEZIFIKATIONEN

PRODUKTBESCHREIBUNG

PRODUKTSPEZIFIKA

TEILELISTE

SPEZIFIKATION

PRODUKTMERKMALE

Die Haftung von Monster Group UK Limited ist auf den Handelswert des Produkts beschränkt.

SICHERHEITSHINWEIS

 SICHERES ARBEITEN

BENUTZERLEITFADEN

MONTAGEANLEITUNGEN

BENUTZERLEITFADEN

WARTUNG

FEHLERBEHEBUNG

LÖSUNGSGUIDE

WAS MACHE ICH, WENN BEI MEINER BESTELLUNG TEILE FEHLEN?

Falls bei Ihrer Bestellung ein Teil zu fehlen scheint, wenden Sie sich bitte innerhalb von 7 Tagen nach Erhalt der Ware an unser freundliches und hilfsbereites Kundenservice-Team.

**FÜR ALLE ANDEREN FRAGEN WENDEN SIE SICH BITTE AN
UNSER KUNDENSERVICE-TEAM.**



ESPECIFICACIONES

DESCRIPCIÓN DEL PRODUCTO

ESPECIFICACIONES DEL PRODUCTO

LISTA DE PIEZAS

ESPECIFICACIONES

CARACTERÍSTICAS DEL PRODUCTO

La responsabilidad de Monster Group UK Limited estará limitada únicamente al valor comercial del producto.

CONSEJOS DE SEGURIDAD

PRÁCTICAS DE TRABAJO SEGURAS

GUÍA DEL USUARIO

INSTRUCCIONES DE ENSAMBLAJE

GUÍA DEL USUARIO

MANTENIMIENTO

SOLUCIÓN DE PROBLEMAS

GUÍA DE RESOLUCIÓN

¿QUÉ PUEDO HACER SI LE FALTAN PIEZAS A MI PEDIDO?

Si parece faltar alguna pieza en su pedido, por favor, comuníquese con nuestro amable y servicial Equipo de Atención al Cliente en los 7 días posteriores a la recepción de su pedido.

**PARA CUALQUIER OTRO PROBLEMA, POR FAVOR CONTACTE
CON NUESTRO EQUIPO DE ATENCIÓN AL CLIENTE**



SPECIFICHE

DESCRIZIONE DEL PRODOTTO

SPECIFICHE DEL PRODOTTO

LISTA COMPONENTI

SPECIFICHE

CARATTERISTICHE DEL PRODOTTO

La responsabilità di Monster Group UK Limited sarà limitata al solo valore commerciale del prodotto.

CONSIGLI PER LA SICUREZZA

 PRATICHE DI LAVORO SICURO

GUIDA UTENTE

ISTRUZIONI PER IL MONTAGGIO

GUÍA DEL USUARIO

MANTENIMIENTO

RISOLUZIONE DEI PROBLEMI

GUIDA ALLA RISOLUZIONE DEI PROBLEMI

COSA DEVO FARE SE NEL MIO ORDINE CI SONO DELLE PARTI MANCANTI?

Se sembra che all'interno del tuo ordine manchino delle parti, contatta il nostro gentile e disponibile team di assistenza clienti entro 7 giorni dalla ricezione del tuo ordine.

**PER QUALUNQUE ALTRO PROBLEMA, CONTATTA IL NOSTRO
TEAM DI ASSISTENZA CLIENTI.**



OMSCHRIJVING

PRODUCT OMSCHRIJVING

PRODUCTSPECIFICATIES

ONDERDELENLIJST

SPECIFICATIE

PRODUCT SPECIFICATIE

De aansprakelijkheid van Monster Group UK Limited is beperkt tot de commerciële waarde van het product.

VEILIGHEIDSADVIIES

 VEILIG GEBRUIK

HANDLEIDING

MONTAGE-INSTRUCTIES

HANDLEIDING

ONDERHOUD

PROBLEEM OPLOSSEN

OPLOSSINGEN

WAT MOET IK DOEN ALS ER ONDERDELEN VAN MIJN BESTELLING ONTBREKEN?

Neem wanneer een onderdeel van je bestelling ontbreekt binnen 7 dagen na ontvangst contact op met onze vriendelijke en behulpzame klantenservice.

**NEEM VOOR ALLE ANDERE KWESTIES CONTACT
MET ONZE KLANTENSERVICE OP.**



SPECIFIKATION

PRODUKTBESKRIVNING

PRODUKTSPECIFIKATIONER

MEDFÖLJANDE DELAR

SPECIFIKATION

PRODUKTFUNKTIONER

SÄKERHETSÅD

 SÄKER ARBETSÖVNING

ANVÄNDARGUIDE

MONTERINGS INSTRUKTIONER

BRUKSANVISNING

SKÖTSEL

FELSÖKNING

LÖSNINGSGUIDE

VAD GÖR JAG OM DET SAKNAS DELAR FRÅN MIN BESTÄLLNING?

Om det verkar som om någon del saknas i din beställning, kontakta vårt vänliga och hjälpsamma kundsupportteam inom 7 dagar efter mottagandet.

**FÖR ALLA ANDRA FRÅGOR, VÄNLIGEN KONTAKTA VÅRT
KUNDSUPPORTTEAM.**

Monster Group (UK) is one of the UK's fastest growing online retailers. We supply a diverse range of products which offer exceptional value for money. We strive to provide the best possible customer experience with free UK delivery across all our products and a Monster Guarantee for 100% satisfaction.

For information regarding this device or other products from our Monster divisions please contact Sales.

SALES

TEL: 01347 878 888

EMAIL: hello@monstershop.co.uk

For queries about this device, warranty, returns or reporting faults please contact Support.

SUPPORT

TEL: 01347 878 887

EMAIL: help@monstershop.co.uk

Pour plus d'informations concernant cet appareil ou d'autres produits de nos divisions de Monster veuillez utiliser les détails suivants ci-dessous.

DÉPARTEMENT COMMERCIAL

TEL: 01347 878 888

EMAIL: bonjour@monstershop.eu

Pour les interrogations concernant cet appareil, la garantie, les retours ou les défauts de déclaration veuillez utiliser les détails suivants ci-dessous.

DÉPARTEMENT DE SOUTIEN

TEL: 01347 878 887

EMAIL: help@monstershop.co.uk

Para información sobre este dispositivo u otros productos de nuestras divisiones de Monster por favor use los siguientes detalles.

DEPARTAMENTO DE VENTAS

TEL: 01347 878 888

EMAIL: hola@monstershop.eu

Para consultas sobre este dispositivo, la garantía, devoluciones o denuncias de fallos por favor use los siguientes detalles.

DEPARTAMENTO DE SOPORTE

TEL: 01347 878 887

EMAIL: help@monstershop.co.uk

Für Informationen bezüglich dieses Geräts oder anderer Produkte aus unserer Monster-Abteilung, benutzen sie die folgenden unten aufgeführten Angaben.

VERKAUFABTEILUNG

TEL: 01347 878 888

EMAIL: hallo@monstershop.eu

Für Fragen über dieses Gerät, die Garantie, Rückgaben oder bei Störungen, benutzen sie die folgenden unten aufgeführten Angaben.

SUPPORT-ABTEILUNG

TEL: 01347 878 887

EMAIL: help@monstershop.co.uk

Per informazioni riguardanti questo dispositivo o altri prodotti dalle categorie Monster utilizzare i dettagli sotto riportati.

DIPARTIMENTO VENDITE

TEL: 01347 878 888

EMAIL: ciao@monstershop.eu

Per domande riguardo dispositivo, garanzia, reso o per riferire di guasti, utilizzare i dettagli sotto riportati.

DIPARTIMENTO SUPPORTO

TEL: 01347 878 887

EMAIL: help@monstershop.co.uk

Monster House, Alan Farnaby Way,
Sheriff Hutton Industrial Estate,
Sheriff Hutton, York, YO60 6PG
www.monstershop.co.uk



 Try **Monster**. Buy **Monster**. Be **Monster**. 