

OWNER'S MANUAL

4 in 1 Garden Tools

MT52



IMPORTANT!

To help reduce the risk of injury, please read instruction manual carefully before operation and keep for future reference.

CONTENTS

INSTRUCTIONS.....	2
INTENDED USE.....	2
SPECIFICATIONS.....	3
SAFETY MESSAGES.....	3
ACCESSORIES.....	8
USAGE.....	8
STORAGE.....	10
DISPOSAL.....	10
MAINTENANCE.....	11
TROUBLESHOOTING GUIDE.....	13

To check how to use the different tools, please check the attached independent manuals.

INSTRUCTIONS

Dear Customer:

Thank you for purchasing our products!

We want to help you to get the best results from your new product and to operate it safely. This manual contains information on how to do that; **please read it carefully** before operating the product. If a problem should arise, or if you have any questions about your product, please contact us.

All information in this publication is based on the latest product information available at the time of printing. We reserve the right to make changes at any time without notice and without incurring any obligation. No part of this publication may be reproduced without written permission.

This manual should be considered a permanent part of the product and should remain with the engine if resold.

INTENDED USE

This appliance is designed for the following applications:

- Brush cutter (when fitted with metal circular blade)

The brush cutter is intended to cut weed and climbing plants. Do not use it for other purposes; never use it for cutting wood. Never cut objects with a diameter exceeding 13mm.

- Grass trimmer (when fitted with nylon line cutting head)

The grass trimmer is intended for trimming grass. Do not use it for other purposes.

- Chainsaw (when fitted with saw chain)

The pruner (pole saw) is intended to be used for trimming fruit trees, cutting back overhanging branches, thinning out treetops and cutting off buckled branches.

- Hedge trimmer (when fitted with reciprocating blade)

The trimmer is intended to be used for trimming hedges and bushes with diameter not more than 24mm.

This product is intended for use by adults only. Keep out of reach of children.

Do not use this appliance for other purposes than those described in this manual.

Note: CHECK WITH LOCAL COUNCIL FOR ANY RESTRICTIONS OF USE.

SPECIFICATIONS

Engine	1E40F-5
Volume (fuel tank)	800cm ³
Engine type	2 stroke
Engine displacement	52 cm ³
Max. engine power /Engine speed (in accordance with ISO 8893)	1.25kW / 7000 min ⁻¹
Engine speed at idling	3200 min ⁻¹
Grass trimmer:	
Nylon line spool	Bump feed, Twin line, line diameter: 2mm
Cutting width	380mm
Brush cutter:	
Blade type	3-tooth metal blade, Ø230mm x Ø25.4mm x 2mm
Cutting diameter	230mm
Hedge trimmer:	
Cutting length of trimmer blade:	410mm
Cutting capacity	Ø 24mm
No-load speed of blade	1400 min ⁻¹
Chainsaw:	
Mass (without fuel, cutting attachment)	6.65kg
Bar length	10 inches (250mm)
Max. Cutting Length	200 mm
Chain speed at no load	10 m/s
Oil tank capacity	120 cm ³

SAFETY MESSAGES

Your safety and the safety of others are very important. We have provided important safety messages in this manual and on the engine. Please read these messages carefully.

A safety message alerts you to potential hazards that could hurt you or others. Each safety message is preceded by a safety alert symbol and one of three words, DANGER, WARNING, or CAUTION.

These signal words mean:



You WILL be KILLED or SERIOUSLY HURT if you don't follow instructions.



You CAN be KILLED or SERIOUSLY HURT if you don't follow instructions.



You CAN be HURT if you don't follow instructions.

Each message tells you what the hazard is, what can happen, and what you can do to avoid or reduce injury.

SAFETY LABEL LOCATION

This label warns you of potential hazards that can cause serious injury. Read it carefully. If the label comes off or becomes hard to read, please contact us for replacement.

WARNING LABELS ON THE MACHINE

They will facilitate essential information on the product or instructions for use.

- Notice: When handling the power chain saw, special safety precautions are required.
- Read and try to understand the entire instruction manual before you get down to using the machine. Non-observance of the instructions before use may be DANGEROUS TO LIFE!



- Warning



- Read the user manual before using the machine.



- Beware of flying objects



- Keep bystanders at least 15 m away



- Beware of sharp blades



- Beware of foot injury



- Beware of falling objects



- Beware of blade thrust



- Wear eye protection, ear muffers and helmet



- Wear sturdy boots to protect yourself from slipping



- Wear glove to protect your hands



- Always beware of the danger from overhead electric-power line, keep a safe distance of at least 10m from the power line

SYMBOLS ON THE MACHINE



For safe operation and maintenance, symbols are carved in relief on the machine.

According to these indications, please be careful not to make a mistake.

The port to refuel the "GASOLINE"

Position: FUEL TANK CAP



The direction to close the choke

Position: AIR CLEANER COVER



The direction to open the choke

Position: AIR CLEANER COVER



If you turn the rod with a screwdriver follow the arrow to the

"MAX" position, the chain oil will flow more, and if you turn to the "MIN" position, less.

Position: Bottom of the TRANSMISSION

SYMBOLS MAY BE ON OR NOT ON THE MACHINE BUT YOU MUST ALSO BEWARE



No fire, no unprotected source of light, no smoking



Beware if health hazardous gases

SAFETY INFORMATION

GENERAL SAFETY INSTRUCTION

- This machine can cause serious injuries. Read the instructions carefully for the correct handling, preparation, maintenance, starting and stopping of the machine. Be familiar with all controls and the proper use of the machine.
- Keep this manual handy so that you may refer to it later whenever any questions arise. Also note, if you have any questions which cannot be answered herein, please contact us.
- Never allow children or anyone unable to fully understand the directions given in the manual to use the machine.

PERSONAL SAFETY EQUIPMENT

- When operating this machine, make sure to wear the following safety equipment:
 - (1) Helmet
 - (2) Ear protectors
 - (3) Protection goggles or face protector
 - (4) Thick work gloves
 - (5) Non-slip-sole work boots
- Do not wear loose clothing, jewelry, short trousers, sandals, or go barefoot. Do not wear anything which might be caught by a moving part of the unit. Secure hair so it is above shoulder length.

WORK PLACE

- Never start the engine inside a closed room or building. Exhaust gases contain dangerous carbon monoxide.
- Never use the product:
 - a. When the ground is slippery or when you can't maintain a steady posture.
 - b. At night, at times of heavy fog, or at any other times when your field of vision might be limited and it would be difficult to gain a clear view of the working area.
 - c. During rain storms, during lightning storms, at times of strong or gale-force winds, or at any other times when weather conditions might make it unsafe to use the product.
- The machine may not be used unless it is undamaged and functions properly. If the equipment or parts of it have become defective, have it repaired by a specialized technician.
- Always obey the current national and international safety, health, and working regulations.
- Do not operate the machine unless you did not find any faults on checking. If a part has become defective, make sure to replace it before you use the machine again.
- The environment must be free of easily flammable and explosive materials.
- Do not overload the machine. Use the machine only for its intended purpose.
- Always work with care, and stay alert: Do not operate the machine when you are tired, ill, or under the influence of alcohol, drugs or medication, as you will no longer be able to operate the machine safely.

BEFOR STARTING THE ENGINE

- Make sure that no persons or animals are within your work area when you start working.
- Make sure there are no obstacles in your work area.

- Ensure that your machine has been fully and properly assembled.
- Check that the machine works properly and make sure, in particular, that the On/Off switch works properly. Do not operate the machine with a damaged or extensively worn cutting device.
- The machine will vibrate during operation. This may cause its screws and parts to loosen. Therefore, check all screws and parts for tightness.

USING THE PRODUCT

▲ WARNING

Cut only materials recommended by the manufacturer. And use only for tasks explained in the manual.

- Keep bystanders and animals at least 15m away from the operating point. If you are approached, immediately stop the engine.
- Grip the handles firmly with both hands using your whole hand.
- Assume a firm standing position during operation:
 - Make sure you cannot slip or fall over.
 - Do not stretch your arms too far in front of you or above your shoulder level.
- After starting the engine, check to make sure that the cutting attachment stops rotating when the throttle is full released. If it continues to rotate even after the throttle has been fully released, turn off the engine and take the unit to the dealer for repair.
- If the unit starts to shake or vibrate, turn off the engine and check the whole unit. Do not use it until the trouble has been properly corrected.
- Keep all parts of your body away from rotating cutting attachment and hot surfaces.
- Never touch the muffler, spark plug, or other metallic parts of the engine while the engine is in operation or immediately after shutting down the engine. Doing so could result in serious burns or electrical shock.
- While the motor is still hot, keep the machine away from anything flammable, such as dry grass, debris, leaves or excessive lubricant.
- Before laying down the machine, make sure the engine is turned off and the cutting attachment is completely stopped!
- Never work alone! Make sure you are within shouting distance or have visual or other kind of contact with another person who will be able to provide first aid in an emergency situation.
- Always be aware of your surroundings and stay alert for possible hazards that you may not hear due to the noise of the machine
- **Never operate the pruner or hedge trimmer at an angle greater than 60° in order to reduce the risk of being struck by falling objects during operation.**
- **Avoid operating while people, especially children are nearby.**
- **Always beware of the danger from overhead electric-power line, keep a safe distance at least 10m from the power line**

MAINTENANCE

- In order to maintain your product in proper working order, perform the maintenance and checking operations described in the manual at regular intervals.
- Always be sure to turn off the engine before performing any maintenance or checking procedures.

▲ WARNING

The metallic parts reach high temperatures immediately after stopping the engine

- Use only original replacement parts. Only these spare parts are guaranteed to be designed and suitable for use with this machine. Using other spare parts will void your warranty and may cause danger to yourself and your surroundings.
- In the event that any part must be replaced or any maintenance or repair work not described in this manual must be performed, please contact us for assistance.
- Under no circumstances should you ever take apart the product or alter it in any way. Doing so might result in the product becoming damaged during operation or the product becoming unable to operate properly.

HANDLING FUEL

- The engine is designed to run on gasoline, which contains highly flammable gasoline. Never store cans of fuel or refill the tank of the unit in any place where there is a boiler, stove, wood fire, electrical sparks, welding sparks, or any other source of heat or fire which might ignite the fuel.
- Never smoke while operating the unit or refilling its fuel tank.
- When refilling the tank, always turn off the engine and allow it to cool down. Take a careful look around to make sure that there are no sparks or open flames anywhere nearby before refueling.
- Wipe spilled fuel completely using a dry rag if any fuel spillage occurs during refueling.
- After refueling, screw the fuel cap back tightly onto the fuel tank and then carry the unit to a spot 3m or more away from where it was refueled before turning on the engine.

TRANSPORT AND STORAGE

- When you finish cutting in one location and wish to continue work in another spot, turn off the engine, lift up the unit and carry it paying attention to the blade.
- When transporting or storing the machine always fit the cutting device guard or guide bar cover.
- When hand-carrying the product, cover over the cutting part if necessary, lift up the product and carry it paying attention to the blade.
- Never transport the product over rough roads over long distances by vehicle without removing all fuel from the fuel tank. If doing so, fuel might leak from the tank during transport.
- Protect the machine from damage when transporting it.
- When transporting or storing the machine, always fit the cutting device transport guard.

KICKBACK SAFETY PRECAUTIONS**▲ DANGER**

- (1) Kickback may occur when the nose or tip of the guide bar touches an object, or when the wood closes in and pinches the saw chain in the cut. Tip contact in some cases may cause a lightning fast reverse reaction, kicking the guide bar up and back towards the operator. Pinching the saw chain along the top of the guide bar may push the guide bar rapidly back towards the operator. Either of these reactions may cause you to lose control of the saw, which could result in serious personal injury.**
 - (2) Do not rely exclusively on the safety devices built into your saw. As a chain saw user you should take several steps to keep cutting jobs free from accident or injury.**
- With a basic understanding of kickback you can reduce or eliminate the element of surprise. Sudden surprise contributes to accidents.
 - Keep a good grip on the machine with both hands, the right hand on the rear handle, and the left hand on the front handle, when the engine is running. Use a firm grip with thumbs and fingers

encircling the machine handles. A firm grip will help you reduce kickback and maintain control of the machine.

- Make certain that the area in which you are cutting is free from obstructions. Do not let the nose of the guide bar contact a log, branch, or any other obstruction which could be hit while you are operating the machine.
- Cut at a high engine speed.
- Follow the manufacturer's sharpening and maintenance instructions for [the saw chain](#).
- Only use replacement bars and chains specified by the manufacturer or the equivalent.

⚠ DANGER

Make sure the chain and guide bar are correctly adjusted before operating the equipment. Never attempt chain adjustment with the engine running!

- Always make sure the cutting attachment is properly installed and firmly tightened before operation.
- Never use a cracked or warped guide bar: replace it with a serviceable one and make sure it fits properly.
- If a saw chain should bind fast in a cut, shut off the engine immediately. Push the branch or tree to ease the bind and free the saw chain.
- Do not operate the machine with the muffler removed.
- When cutting a limb that is under tension, be alert for springback so that you will not be struck by the moving limb.
- Always stop the engine immediately and check for damage if you strike a foreign object or if the machine becomes tangled. Do not operate with broken or damaged equipment.

⚠ WARNING

Do not make unauthorized modifications or substitutions to the guide bar or chain. Never allow the engine to run at high speed without a load. Doing so could damage the engine.

Keep the machine as clean as possible. Keep it free of loose vegetation, mud, etc



Residual risks

Even when the tool is used as prescribed it is not possible to eliminate all residual risk factors. The following hazards may arise in connection with the tool's construction and design:

1. Damage to lungs if an effective dust mask is not worn.
2. Damage to hearing if effective hearing protection is not worn.
3. Health defects resulting from vibration emission if the power tool is being used over longer period of time or not adequately managed and properly maintained.

WARNING! This machine produces an electromagnetic field during operation. This field may under some circumstances interfere with active or passive medical implants. To reduce the risk of serious or fatal injury, we recommend persons with medical implants to consult their physician and the medical implant manufacturer before operating this machine.

OPERATION

BEFORE OPERATION CHECKS

▲ WARNING

For your safety, and to maximize the service life of your equipment, it is very important to take a few moments before you operate the engine to check its condition. Be sure to take care of any problem you find, or let us correct it.

Before beginning your pre-operation checks, be sure the engine stop switch is in the OFF position.

Always check the following items before you start the engine:

- Cutting head correct mount
- Switches easy run
- The ignition plug is safely mounted. If the plug is loose, sparkle and subsequent ignition of fuel-air mixture may occur.
- Make sure that handgrips are clean so that scythe may be led safely.
- The cutting head must move freely.
- Check and adjust the harness to suit for your body size.
- Check the damage of parts including the cutting device.
- To reduce fire hazards, keep the engine and silencer free of debris, leaves and excessive lubricant.

▲ DANGER

If in doubt when putting the machine in operation, take advice from a professional of an authorised servicing centre.

Non-professional advice may be dangerous to life!

FUEL AND CHAIN OIL

▲ DANGER

Gasoline is very flammable. Avoid smoking or bringing any flame or sparks near fuel. Make sure to stop the engine and allow it cool before refueling the unit. Select outdoor bare ground for fueling and move at least 3 m (10 ft) away from the fueling point before starting the engine.

If the fuel tank is drained, this should be done outdoors.

■ FUEL:

Please use the lead-free pure gasoline

■ CHAIN OIL

Use motor oil SAE #10W-30 all year round or SAE#30 ~#40 in summer and SAE #20 in winter.

SAFE OPERATING PRECAUTIONS

Before operating the engine for the first time, please review the SAFETY INFORMATION and the BEFORE OPERATION CHECKS!

- Hold the equipment firmly and safely with both the hands!
- Work thoughtfully and do not expose anybody to a risk while operation. Be calm and

considerate while working.

- Observe the cutting head!
- Never work standing on a ladder!
- Work on firm and stable bases only!
- In the course of work procedure, make sure that no persons or animals are standing within 15 m diameter. Switch the machine off immediately if anybody, children in the first place, enter the reach of machine
- Use the machine at daylight only.
- Do not work unless the visual and lighting conditions are good!

To turn the machine off, the switch has to be in "OFF" position.

- Respect municipal and communal regulations when operating the machine.
- Do not use the machine during general rest periods.
- Any hard objects – stones, metal parts etc. – have to be removed. They could be thrown away and cause personal or material damage.
- Working in high shrubs or bushes, the working height must be 15 cm as a minimum not to expose animals, such as hedgehogs to any risk.

Grass Trimming

-Working on grass areas, hold the machine at an angle of approx. 30° and make semicircle turns to the left and right.

The best results are achieved with grass 15 cm high. If it is higher, it is recommended to repeat mowing several times.

CAUTION! When the machine is running never put the cutting head on the ground.

If the trimming output decreases

- 1) Hold the running machine over the grass and knock the ground several times with the cutting head the nylon line will get prolonged in thus way.
- 2) The cutter enclosed in the protection shield will cut the nylon line to the required length.

Caution! The nylon line remnant may be thrown off and cause an injury.

If the machine is vibrating:

Clean it or, where necessary, remove the grass stuck on the cutting head and protection shield.

ACCESSORIES

- engine
- pole chain saw head assembly(include attachment tube)
- extension tube assembly (Optional)
- pole hedge trimmer head assembly
- Brush cutter head assembly
- Nylon cutting head
- screw driver
- spanner
- owner's manual

USAGE

SET UP THE EQUIPMENT

JOINT ATTACHMENT

Assemble the poles with coupler.



INSTALLING HANDLE

1 insert the barrier handle to the top handle



2 Fasten the 4 internal hexagonal screws with spanner.

START ENGINE

1. Before starting the engine, ensure the mix rate of the petrol and oil is 40:1
2. Move the switch to ON position
3. Push the primer bulb repeatedly (7-10times) until fuel comes into the primer bulb
4. Pull the choke up
5. Pull the throttle lever a little and push down the upper throttle lock button
6. Pull the starter rope vigorously 2 to 3 times with the other hand
7. Push the choke downwards
8. Pull the starter again to run the engine
9. If engine does not start go back to step 4

⚠ WARNING

The product is equipped with a centrifugal clutch mechanism, so the cutting attachment

begins to rotate as soon as the engine is started by putting the throttle trigger into the start position. When starting the engine, place the product onto the ground in a flat clear area and hold it firmly in place so as to ensure that neither the cutting part nor the throttle trigger come into contact with any obstacle when the engine starts.

Please ensure that the cutting attachment stops turning when engine idles, if it is running while engine idles, please have it repaired by dealer or authorized technician.

⚠ CAUTION

Do not pull too far. Watch the cutting/mowing head while pull the starting cable.

NOTE

1. When restarting the engine immediately after stopping it, leave the choke open.
2. Over-choking can make the engine hard to start due to excess fuel. When the engine failed to start after several attempts, open the choke and repeat pulling the rope, or remove the spark plug and dry it.

STOPPING ENGINE

1. Release the throttle lever and run the engine for half a minute.
2. Shift the stop switch to the “OFF” position.

⚠ WARNING

- **Except for an emergency, avoid stopping the engine while pulling the throttle lever.**
- **When it doesn't stop at the stop switch, move the choke level to the closed position.**

NOTE !

The oil reservoir has a capacity sufficient to provide about 40 minutes of cutting time (when set to deliver the minimum flow rate, or about as long as you'll get from a tank of fuel). Be sure to refill the oil tank every time when refueling the saw.

STORAGE

Aged fuel is one of major causes of engine starting failure. Before storing the unit, empty the fuel tank and run the engine until it uses all the fuel left in the fuel line and the carburetor.

If the fuel tank is drained, this should be done outdoors.

Cleaning and maintenance of the machine should be performed before storage.

Store the unit indoor without direct sunlight and taking necessary measures for rust prevention.

Store the unit in a locked place out of reach of children.

Store the unit where the fuel vapour will not reach an open flame or spark. Always allow the machine to cool down before storing.

When storing the machine, always fit the cutting device transport guard.

DISPOSAL

When disposing your machine, fuel or oil for the machine, be sure to follow your local regulations.

MAINTENANCE

THE IMPORTANCE OF MAINTENANCE

Good maintenance is essential for safe, economical and trouble-free operation. It will also help reduce pollution.

▲ DANGER

- **Improper maintenance, or failure to correct a problem before operation, can cause a malfunction in which you can be seriously hurt or killed.**
- **Always follow the inspection and maintenance recommendations and schedules in this owner's manual.**

To help you properly care for your equipment, the following pages include a maintenance schedule, routine inspection procedures, and simple maintenance procedures using basic hand tools. Other service tasks that are more difficult, or require special tools, are best handled by professionals and are normally performed by your dealer or other qualified mechanic.

▲ WARNING

- **Make sure that the engine has stopped and the sparkplug wire is disconnected, and is cool before performing any service to the machine. Contact with moving cutting head or hot muffler may result in a personal injury.**
- **Read the instructions before you begin, and make sure you have the tools and skills required.**
- **To reduce the possibility of fire or explosion, be careful when working around gasoline. Use only a nonflammable solvent, not gasoline, to clean parts. Keep cigarettes, sparks and flames away from all fuel related parts.**

MAINTENANCE SCHEDULE

Maintenance		System/component						
		Each time you use	1 month/ 5 hours	3month/ 25 hours	6 month/ 50 hours	12month/ 100hours	24month/ 250hours	
Engine oil	Check the oil level	■						
	replacement		■		■			
air cleaner	check	■						
	clean			■a				
spark plug	Check and adjustment					■		
	replacement						■	
clutch	check				■b			
idle	replacement					■b		
Valve clearance	replacement					■b	■b	
Combustion chamber	clean	After every 250 hours operation						
Fuel filter	check					■		

fuel pipe		check	Every 2 years				
others	System/components	Procedure	Before use	Every 25 hours after	Every 50 hours after	Every 100 hours after	Note
	throttle lever, stop switch	check operation	✓				
	cutting parts	replace if something's wrong	✓				Pole hedge trimmer only
	transmission	grease		✓(b)			
	screws/nuts/bolts	tighten/replace	✓			✓	Not adjusting screws
	guide bar	clean	✓				Pole chain saw only
	sprocket	inspect/replace			✓		Pole chain saw only
	saw chain	inspect/sharp	✓				Pole chain saw only

(a) Service more frequently when used in dusty areas.

(b) These items should be serviced by your servicing dealer, unless you have the proper tools and are mechanically proficient.

ENGINE

AIR CLEANER

The air cleaner clogged, will reduce the engine performance. Check and clean the filter element in warm, soapy water as required. Dry completely before installing. If the element is broken or shrunk, replace with a new one.

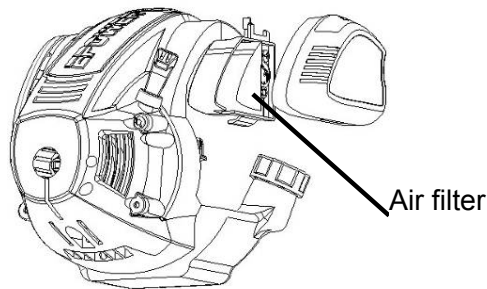

SPARK PLUG

Starting failure and misfiring are often caused by a fouled spark plug. Clean the spark plug and check that the plug gap is in the correct range.

Always replace a defective spark plug with a new one with same specifications.

Remove carbon

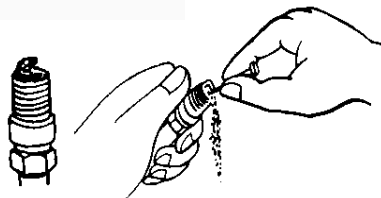

Demolished spark plug

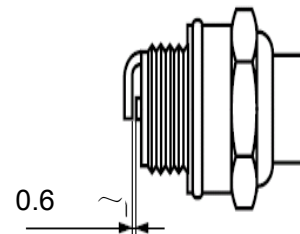
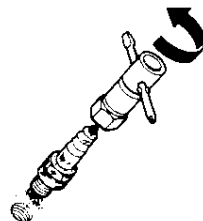

CAUTION

- Note that using any spark plug other than those designated may result in the engine failing to operate properly or in the engine becoming overheated and damaged.
- To install the spark plug, first turn the plug until it is finger tight, then tighten it a quarter turn more with a socket wrench.

Tightening torque: 9.8 ~ 11.8 N.m (1 ~ 1.2 kg.m)

MUFFLER

⚠ WARNING

- Inspect periodically, the muffler for loose fasteners, any damage or corrosion. If any sign of exhaust leakage is found, stop using the machine and have it repaired immediately.
- Note that failing to do so may result in the engine catching on fire.

Remove the muffler, insert a screwdriver into the vent, and wipe away any carbon buildup. Wipe away any carbon buildup on the muffler exhaust vent and cylinder exhaust port at the same time.



TROUBLESHOOTING GUIDE

Case 1. Starting failure

CHECK		PROBABLE CAUSES		ACTION
fuel tank	→	incorrect fuel	→	drain it and use correct fuel
fuel filter	→	fuel filter is clogged	→	clean
carburetor adjustment screw	→	out of normal range	→	adjust to normal range
sparkling (no spark)	→	spark plug is fouled/wet	→	clean/dry
	→	plug gap is incorrect	→	correct (GAP: 0.6 ~ 0.7 mm)
spark plug	→	disconnected	→	retighten

Case 2. The engine will not reach the maximum output

CHECK		PROBABLE CAUSES		ACTION
Spark plug	→	Fouled plug, (the carbon residues on electrodes) too big distance between the electrodes.	→	Clean the plug, check the thermal value and replace it if necessary Set 0.6 - 0.7 mm

carburettor	→	Fouled carburetor or carburetor jets.	→	Clean the carburetor blow it off
Air filter	→	Fouled air filter	→	Clean
exhaust	→	Exhaust, exhaust pipe	→	Remove the exhaust pipe, clean and remove carbon residues.
Cylinder /piston /piston ring	→	The packing ring in the crankcase leaking Worn cylinders, pistons, piston rings	→	Replace the cylinder, piston or piston rings, grind cylinder and piston, install
fuel	→	Poor fuel mix (too much oil	→	Fill up according to instructions

Case 3. The engine will not stop

CHECK		PROBABLE CAUSES		ACTION
Spark plug	→	The plug is pale grey with marks of white-hot (melting drops)	→	Fit in the plug of higher thermal value.
Cylinder	→	Carbon residue in the Ignition area.	→	Clean the cylinder head, piston bottom and cylinder the engine block

Case 4. The pruner runs but is not cutting

CHECK		PROBABLE CAUSES		ACTION
Guide bar & Saw chain	→	The chain is fitted in reverse on the guide bar	→	Refer to the assembly of guide bar and chain

Case 5. Insufficient chain lubrication.

CHECK		PROBABLE CAUSES		ACTION
Oil tank	→	Oil tank empty.	→	Replenish oil tank.
Guide bar	→	Has the oil guide groove of the saw rail become clogged?	→	Clean the oil guide groove.

OWNER'S MANUAL

Hedge trimmer



IMPORTANT!

To help reduce the risk of injury, please read this instruction manual carefully before operation and keep for future reference.

OPERATION OF POLE HEDGE TRIMMER

▲ DANGER

This product is equipped with extremely sharp blades, and when used improperly these blades can be extremely dangerous. Improper handling can cause accidents, which may lead to serious injury or death. For this reason, you should always be careful to follow the following instructions when using your trimmer.

- Ensure that no one is in your work area prior to use.
- Keep away from children and pets.
- Never hold the trimmer in a way in which the blades are pointed towards someone else.
- Never allow the blades to come into proximity with your body while the engine of the trimmer is in operation.
- Always be sure to turn off the engine before changing the angle of the blades, removing branches which have become stuck in the blades, or at any other time when coming into close proximity with the blades.
- Always wear work gloves made of leather or some other sturdy material when using the trimmer.
- Always place the blade cover provided with the trimmer over the blades when not in use.
- Falling branches may fall onto the face or into the eyes, resulting in injuries, scratches, and cuts, and for this reason you should always be sure to wear a helmet and face protector when using your trimmer.

▲ CAUTION

The thickness of branches, which may be cut using this trimmer, is limited to up to approximately 24 mm. Never try to cut branches thicker than this, as doing so may result in damage to the trimmer.

ADJUSTING THE ANGLE OF THE CUTTING BLADES

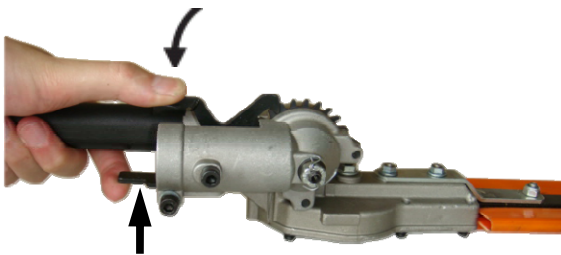

1. Stop the engine.
2. Lift the lock lever and press down the adjusting lever.
3. Adjust the angle of the blades to the desired angle and loose your hand.

MAINTENANCE

TRANSMISSION

The reduction gears are lubricated by multipurpose grease in the transmission. Grease should be added every 25 hours of use or more often depending on the job condition. When adding lubricant, use a grease gun to insert lubricant into the three grease nipples located on the transmission.

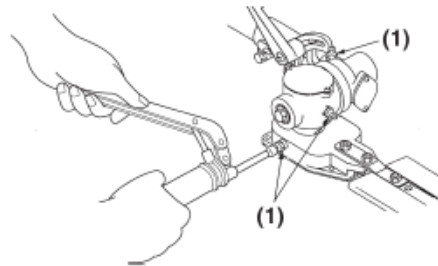

(1) Grease fitting

HEDGE TRIMMER:

BLADE:

- When refilling the tank or resting, it is often a good idea to use the time to oil the cutting blades.
- If a gap exists between the upper and lower blades, follow the procedure below to adjust them so that they fit more closely together.

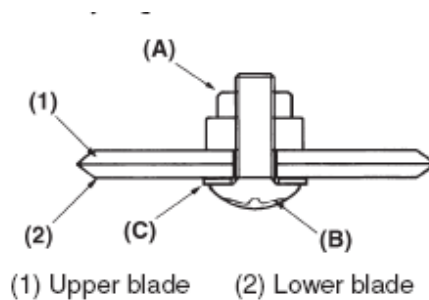

(1) Upper blade (2) Lower blade

1. Loosen lock nut (A) as shown in the diagram.
2. Tighten screw (B) fully, and then turn one-third to one half of a rotation backward.
3. While holding onto the screw to keep it in position, tighten the lock nut.
4. Check to make sure that the flat washer (C) is loose enough so that it may be turned by pressing on it with

NOTE!

Screwing in the screw too tightly may make it impossible for the blades to move. Conversely, not screwing in the screw tightly enough may make the blades of the trimmer feel dull and cause leaves and branches to become caught in the blades of the trimmer.

OWNER'S MANUAL

Brush/Grass cutter



IMPORTANT!

To help reduce the risk of injury, please read this instruction manual carefully before operation and keep for future reference.

GRASS TRIMMER OR BRUSH CUTTER SET UP

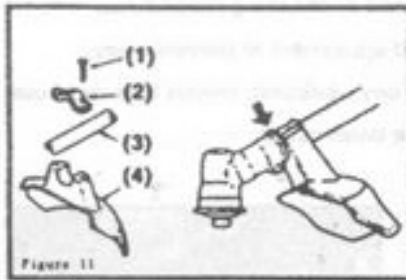

Figure 11

■ SAFETY GUARD

Attach the safety guard to the gear case and fix it with the clamp and 2 bolts (M5*25) securely. (Figure 11)

- (1) Bolt
- (2) Clamp
- (3) Main pipe
- (4) Safety guard

■ INSTALLING THE METAL BLADE (Figure 12)

1. Set the inner holder to the gear shaft, and turn to fix with the attached L-shaped bar.
2. Put the blade on the inner holder with letters to the gear case, and match correctly the hole of the blade to the projection of the inner holder.
3. Set the outer holder to the gear shaft with the hollowed face to the blade.

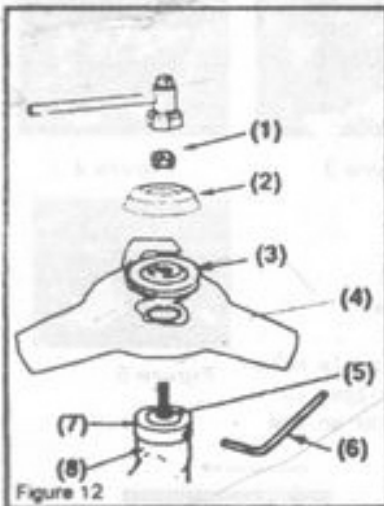

Figure 12

4. Put the attached bolt cover on the outer holder and secure it with the bolt (left screw) together with the spring washer and the washer.

- (1) Nut
- (2) Outer holder 1
- (3) Outer holder 2
- (4) Blade
- (5) Gear shaft
- (6) Bar
- (7) Inner holder
- (8) Gear case

■ INSTALLING THE NYLON CUTTER (OPTION) (Figure 13)

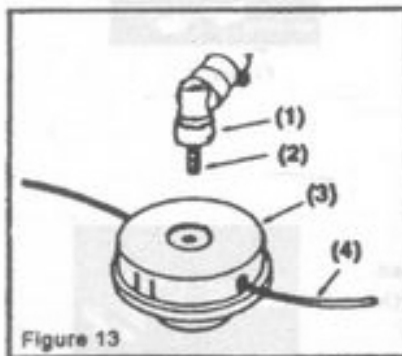

Figure 13

1. Set correctly the inner holder and the outer holder to the gear shaft.
2. Screw the attached bolt (M8 Left) into the gear shaft and secure it with the spanner.
3. Screw the nylon cutter into the bolt by fixing the inner holder with the L-shaped bar and tighten it manually.

NOTE

Keep bolts and washers to install the blade carefully so as not to lose them.

- (1) Gear Case
- (2) Bolt
- (3) Nylon cutter
- (4) Nylon cord

OPERATING THE BRUSH CUTTER

Hold the device with the right hand at the rear handle and with the left hand at the front handle. Try to hold the device at a comfortable level at your hip and always use both hands. Always make sure you maintain a steady firm stance to maintain balance at all times.

BLADE THRUST

Take great care using the blade with the device. Thrust is a reaction that occurs when the blade hits objects that it can not cut. This can make the blade stop and “push away” the tool from the object that was unable to be cut. This reaction can be intense enough to lose control of the object, this process can occur without a warning, as soon as the blade hits an obstacle and stands still. It will occur in areas, where you cannot see exactly what you are cutting. This is why you always should cut from right to left to minimize the reactions.

CUTTING TECHNIQUES OF BLADE

⚠ WARNING

Take great care with the blade. Read SAFETY INSTRUCTIONS in your instruction manual

- Keep the device with both hands at the handle on your right side. Ensure a secure hold.
- Make sure you stand firmly on both feet, to not loose balance because of possible setbacks.
- Check and clean the area from hidden objects like stones, glass, fences, wood etc.
- Never use the blade near curbs, fences, buildings or other immobile objects.
- Do not use the blade after hitting a hard object and without inspection. Do not use it after you discovered damages.
- The device can be used as a scythe by cutting from right to left in a large movement.

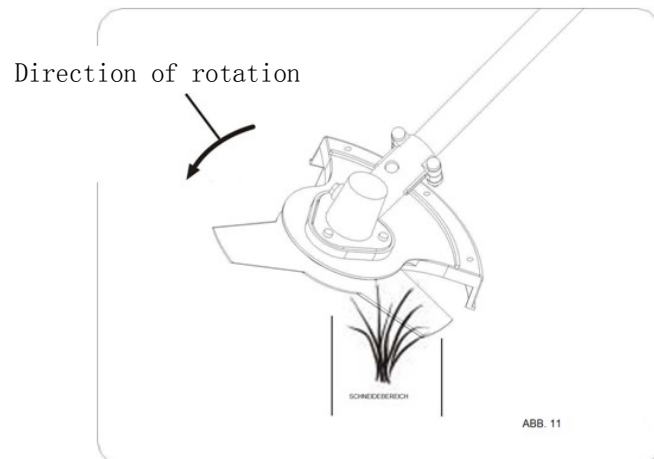

OWNER'S MANUAL

Chainsaw



IMPORTANT!

To help reduce the risk of injury, please read this instruction manual carefully before operation and keep for future reference.

CHAIN TENSION SET UP

⚠ WARNING

- The saw chain has very sharp edges. Use protective gloves for safety.
- Always pay attention to the chain tension. A slackened chain will increase the risk of backlash. If slackened, the chain could spring out of the guide, could cause injury to the operator and as well as damage to the unit. A slackened chain wears out very quickly and the sprocket wheel and the guide bar wears out.

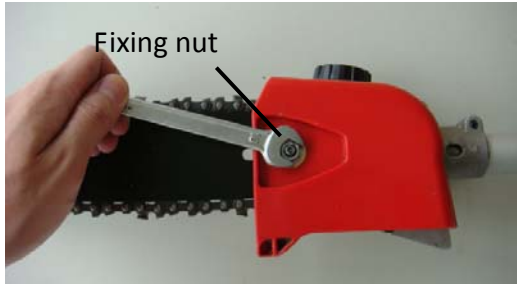

1. Unscrew the fixing nut.

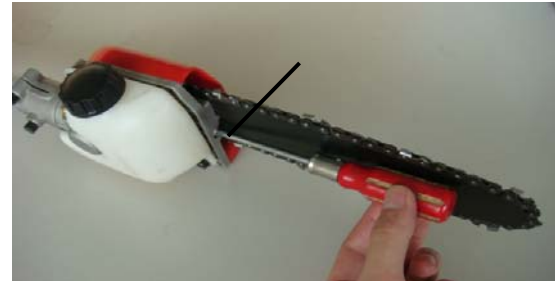

2 Turn the adjusting screw until the chain fits but may be moved with ease.

CHANGE GUIDE BAR OR SAW CHAIN

REMOVE THE GUIDE BAR AND SAW CHAIN

1 Unscrew the fixing nut and remove the chain wheel guard.



Chain wheel guard

2 Remove the saw chain and guide bar.

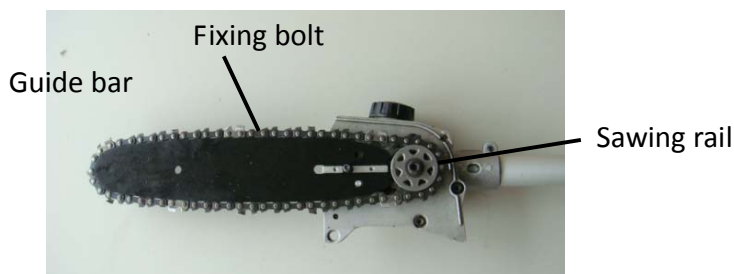

3 Now you can change the bar or the saw chain.

INSTALLING THE GUIDE BAR AND SAW CHAIN

1 Place the sawing chain onto the sawing rail.



2 Position the guide bar so that the chain tensioning stud projects into the guide bar, **Ensure that the saw chain runs in the correct direction!**

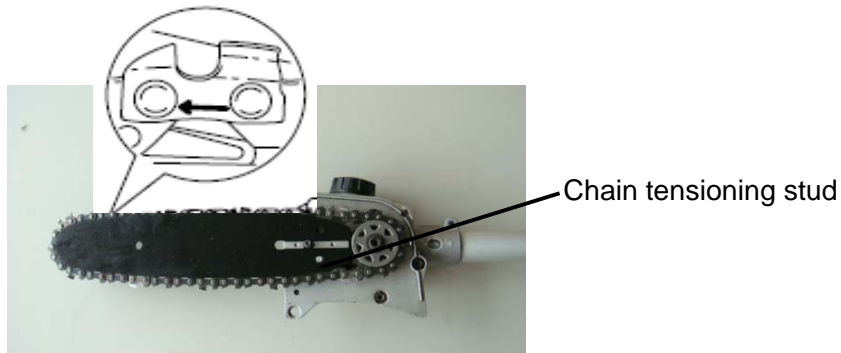

3 Attach the chain wheel protection and then tighten the fixing bolt lightly.



4 Tighten the tensioning screw.



5 Tighten the fixing nut.

NOTE!

The chain should not sag, but it should be possible to pull it a few millimeters away from the saw rail.

Pole chain saw only:

Feed the chain oil into the oil tank and tighten the cap securely.

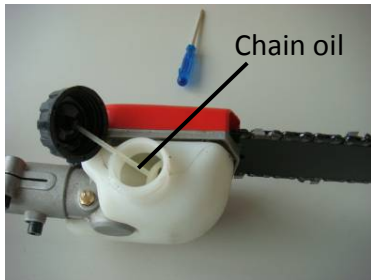

OPERATION OF POLE SAW

▲ DANGER

- Always wear work gloves made of leather or some other sturdy material when using the pole saw.
- Falling branches may fall onto the face or into the eyes, resulting in injuries, scratches, and cuts, and for this reason you should always be sure to wear a helmet and face protector when using your pole saw.
- Beware of the rebound branches after they fall down and hit the ground.

CHECKING OIL SUPPLY

After starting the engine, run the chain at medium speed and see if chain oil has scattered off, as shown in the figure.

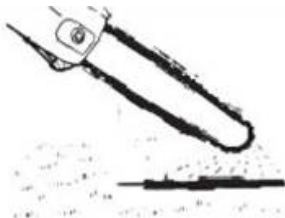

NOTE !

The oil reservoir has a capacity sufficient to provide about 40 minutes of cutting time (when set to deliver the minimum flow rate, or about as long as you'll get from a tank of fuel). Be sure to refill the oil tank every time when refueling the saw.

ADJUSTING OIL FLOW RATE

⚠ CAUTION

Never fill the oil reservoir nor adjust the oiler with the engine running.

An increase in bar oil flow rate will speed oil consumption, requiring more frequent checks on the oil reservoir. To ensure sufficient lubrication, it may be necessary to check the oil level more frequently than at fuel tank refills.

The guide bar and chain are lubricated automatically by a pump that operates whenever the chain rotates. The pump is set at the factory to deliver a minimum flow rate, but it can be adjusted in the field. A temporary increase in oil flow is often desirable when cutting things like hardwood or wood with a lot of pitches.

Adjust the pump as follows:

1. Stop the engine and make sure the stop switch is in the "O" position.
2. Place the unit on its side with the oil reservoir up.
3. With a screwdriver, push in on the oil flow rate adjusting screw and turn in the desired direction

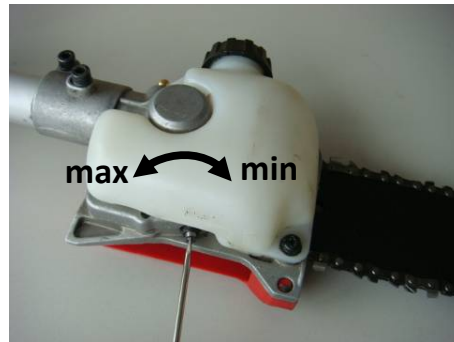

⚠ CAUTION

The oil flow adjusting screw must be pressed in slightly in order to turn. Failure to do so could damage the pump and screw.

Working with the pole chain saw:

- Do not work with an angle higher than 60°. The pole saw will work under higher degrees, but there is the danger of being injured by branches falling without warning. Keep an eye at the ground while working to avoid tripping over fallen branches.
- Never use the pruner without oil, use bio-degradable chainsaw oil. Please keep in mind that this pruner, like all chainsaws, flings oil from the chain during operation. Protect yourself from falling oil drops with suitable protective glasses and clothing.
- To operate the pruner, press down the throttle lockout and then pull the throttle trigger.
- The pruner is equipped with a low-kickback chain and it was also done everything from an engineering point of view to keep kickback low. Nevertheless, some kickback can not be avoided when cutting with the upper tip of the blade. Be prepared for some kickback when using this area of the blade or hitting another branch with this area. Always hold the unit firmly in both hands.
- Thin branches can be cut off with one single cut. To prevent the branch from slivering and buckling the branch should be cut off in several pieces.
- When cutting off lager branches, you should first cut into the branch from below. First cut into the branch from below outside the place where you intend to cut off the branch. The cut should go from one third to halfway through the branch. This prevents the branch from buckling when you cut into the branch from the top outside the first cut. Last, cut off the stump with one clean cut. You might want to seal the cut with a suitable compound.

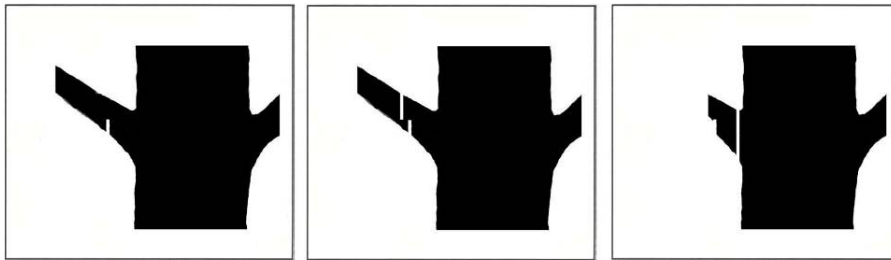

First Cut

Second Cut

Third Cut

- operation.
- Always be sure to turn off the engine before changing the angle of the blades, removing branches which have become stuck in the blades, or at any other time when coming into close proximity with the blades.
- Always wear work gloves made of leather or some other sturdy material when using the trimmer.
- Always place the blade cover provided with the trimmer over the blades when not in use.
- Falling branches may fall onto the face or into the eyes, resulting in injuries, scratches, and cuts, and for this reason you should always be sure to wear a helmet and face protector when using your trimmer.

POLE CHAIN SAW

OILING PORT

Dismount the guide bar and check the oiling port for clogging.

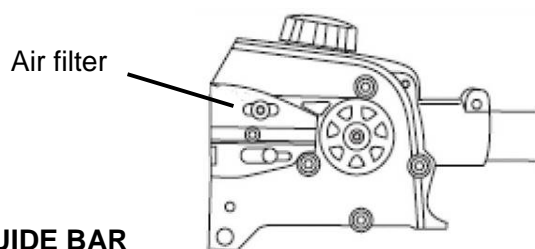

Air filter

GUIDE BAR

Remove sawdust in the bar groove and the oiling port.

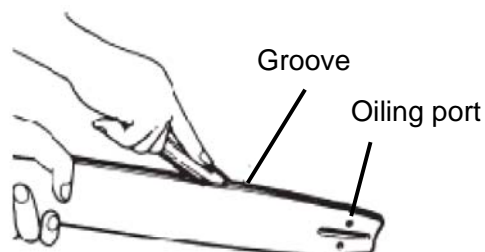

Groove

Oiling port

The bar rail should always be a square. Check for wear of the bar rail. Apply a ruler to the bar and the outside of a cutter. If a gap is observed between them, the rail is normal. Otherwise, the bar rail is worn. Such a bar needs to be corrected or replaced.

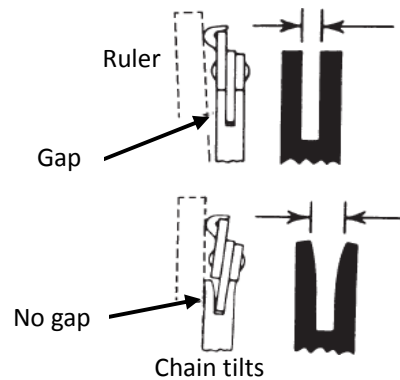

SPROCKET

Check for extensive wear, and replace it when the teeth are worn over 0.3 mm.

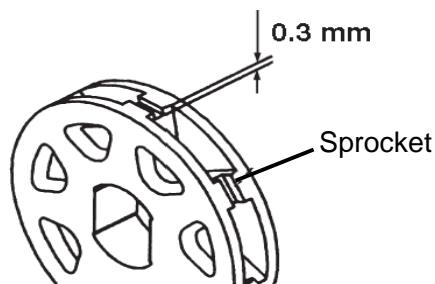

SAW CHAIN

▲ CAUTION

It is very important for smooth and safe operation to keep the cutters always sharp.

Your cutters need to be sharpened when:

- Sawdust becomes powder-like.
- You need extra force to saw in.
- The cut way does not go straight.
- Vibration increases.
- Fuel consumption increases.

CUTTER SETTING STANDARDS

▲ WARNING

Be sure to wear safety gloves.

Before filing:

- Make sure the saw chain is held securely.

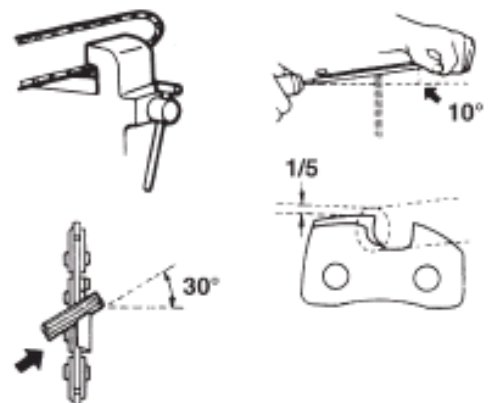

- Make sure the engine is stopped.
- Use a round file of proper size for your chain.
- Chain type : 91PJ
- File size : 5/32 in (4.0 mm)

Place your file on the cutter and push straightforward.
Keep the file position as illustrated.

After every cutter has been set, check the depth gauge and file it to the proper level as illustrated.

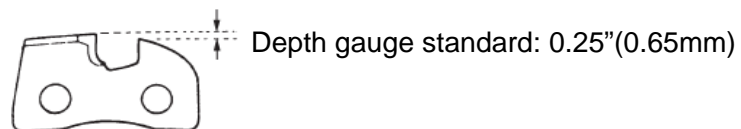
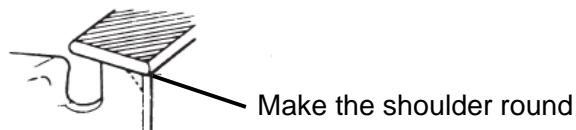
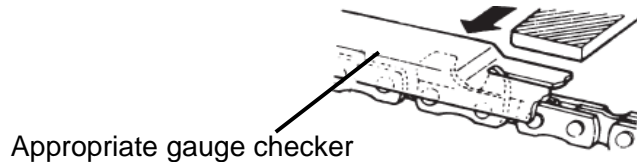

NOTE!

Be sure to round off the front edge to reduce the chance of kickback or tie-strap breakage.
Make sure every cutter has the same length and edge angles as illustrated.



Cutter length



Side plate angle

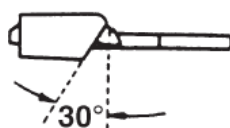

Filing angle



Top plate cutting angle

TRANSMISSION

The reduction gears are lubricated by multipurpose, lithium-based grease in the transmission.

Supply new grease every 25 hours of use or more often depending on the job condition.

When adding lubricant, use a grease gun to insert lubricant into the three grease nipples located on the transmission.

