

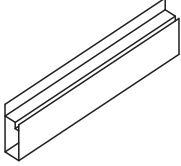

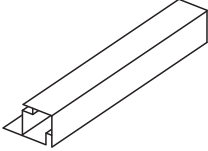
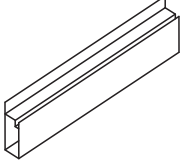
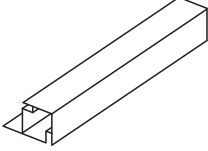
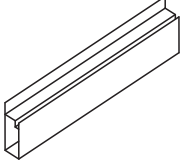
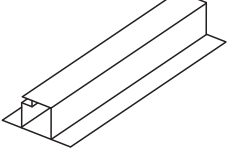
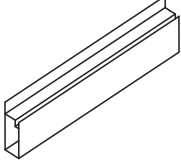
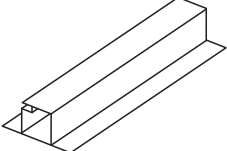
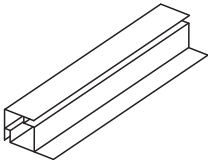
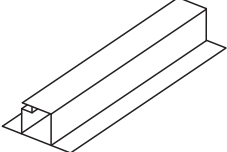
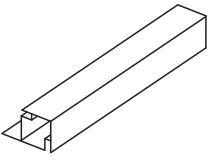
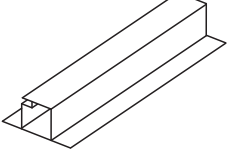
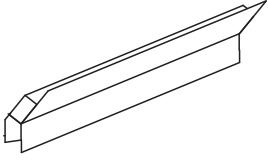
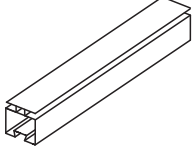
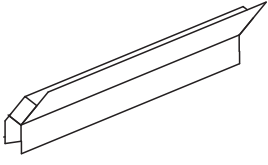
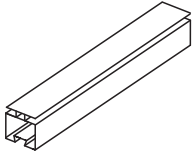
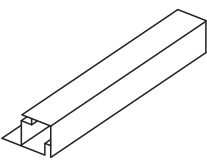
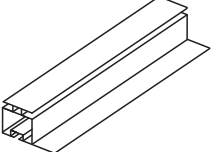
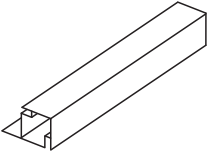
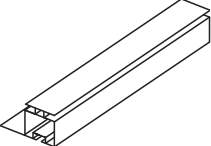
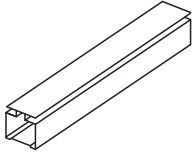
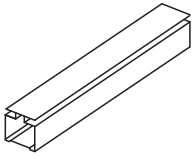
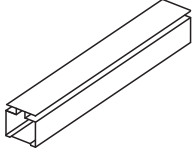
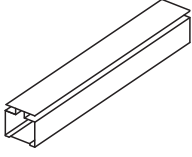
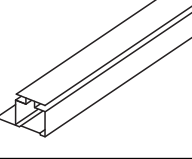

## Aluminum Parts :

| No. | Picture   | Qty. | Size  | No. | Picture  | Qty. | Size  |
|-----|---|------|-------|-----|--|------|-------|
| 1   |    | 2    | 147.7 | 10  |    | 1    | 97.5  |
| 2   |    | 2    | 147.7 | 11  |    | 1    | 97.5  |
| 3   |    | 1    | 172   | 12  |    | 1    | 168.2 |
| 4   |   | 1    | 172   | 13  |   | 1    | 168.2 |
| 5A  |  | 2    | 133.2 | 14  |  | 1    | 170.2 |
| 5B  |  | 2    | 133.2 | 15  |  | 1    | 170.2 |
| 6   |  | 2    | 147.7 | 16  |  | 8    | 133.2 |
| 7   |  | 2    | 147.7 | 17  |  | 6    | 99    |
| 8   |  | 1    | 97.5  | 18A |  | 1    | 98.6  |
| 9   |  | 1    | 97.5  | 18B |  | 1    | 98.6  |

| No. | Picture   | Qty. | Size  | No. | Picture   | Qty. | Size  |
|-----|---|------|-------|-----|---|------|-------|
| 19  |    | 2    | 52.2  | 27  |   | 2    | 56    |
| 20  |    | 2    | 55.1  | 28  |   | 1    | 56    |
| 21  |    | 1    | 63    | 30  |   | 1    | 58*58 |
| 22  |   | 1    | 57    | 31  |  | 4    | 147.7 |
| 23  |  | 2    | 147.7 |     |   |      |       |
| 24  |  | 1    | 57.2  |     |   |      |       |
| 25  |  | 1    | 159   |     |   |      |       |
| 26  |  | 1    | 159   |     |   |      |       |

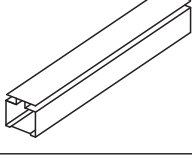
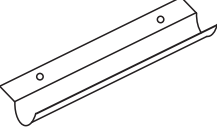
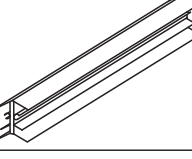
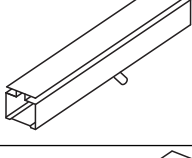
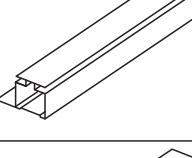
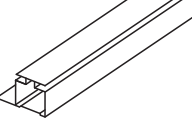
### Plastic Parts:

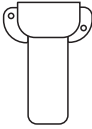
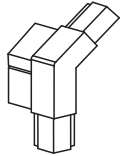
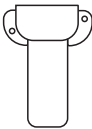
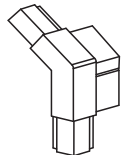
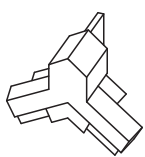
| No. | Picture   | Qty. | Size | No. | Picture   | Qty. | Size |
|-----|---|------|------|-----|---|------|------|
| 32  |  | 4    |      | 35A |  | 2    |      |
| 33A |  | 2    |      | 35B |  | 2    |      |
| 33B |  | 2    |      |     |   |      |      |
| 34  |  | 2    |      |     |   |      |      |

### Hardware:

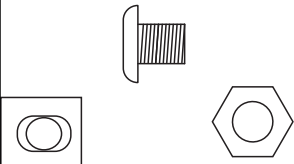
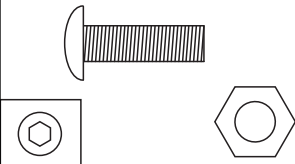
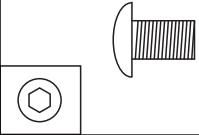
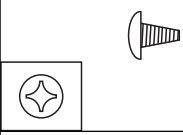
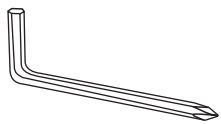
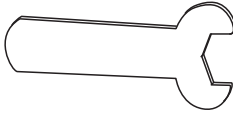
| No. | Picture   | Qty. | Size  | No. | Picture  | Qty. | Size  |
|-----|---|------|-------|-----|--|------|-------|
| 41  |  | 28   | M6*9  | 44  |  | 4    | M6*26 |
| 42  |  | 64   | M6*12 |     |  |      |       |
| 43  |  | 16   | M4*8  |     |  |      |       |
|     |   |      |       |     |  |      |       |
|     |  |      |       |     |  |      |       |

## Twin PC Board:

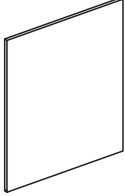
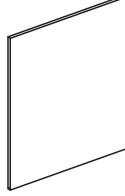
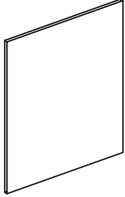
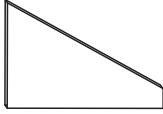
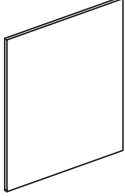
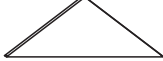
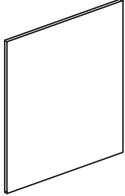
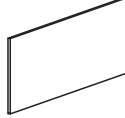
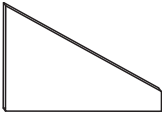
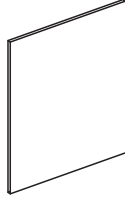
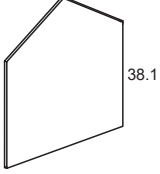
| No. | Picture   | Qty. | Size            | No. | Picture  | Qty. | Size            |
|-----|---|------|-----------------|-----|--|------|-----------------|
| A   |    | 10   | 136*58.7        | G   |    | 2    | 132.7*54        |
| B   |    | 9    | 102*58.7        | H   |    | 2    | 34.8*54<br>*3.7 |
| C   |   | 2    | 132.7*56.9      | I   |   | 1    | 20*63<br>*1.2   |
| D   |  | 1    | 132.7*58.8      | J   |  | 1    | 39.8*58.7       |
| E   |  | 2    | 37*56.9<br>*3.7 | K   |  | 2    | 79.8*57.6       |
| F   |  | 1    | 55*58.8         |     |  |      |                 |

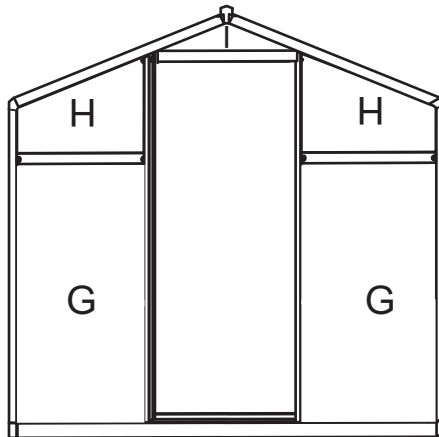
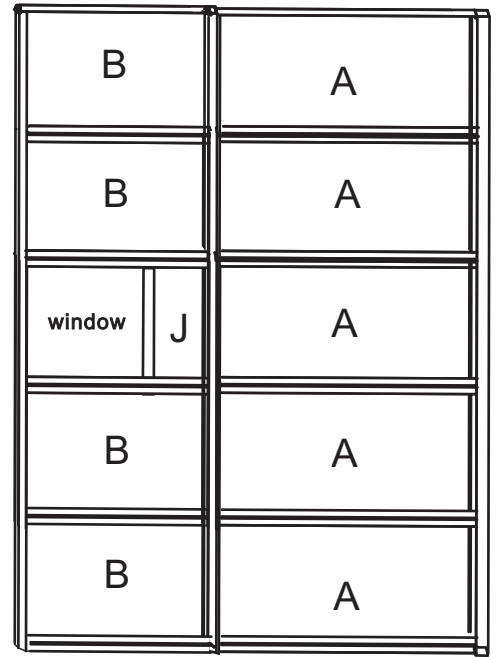
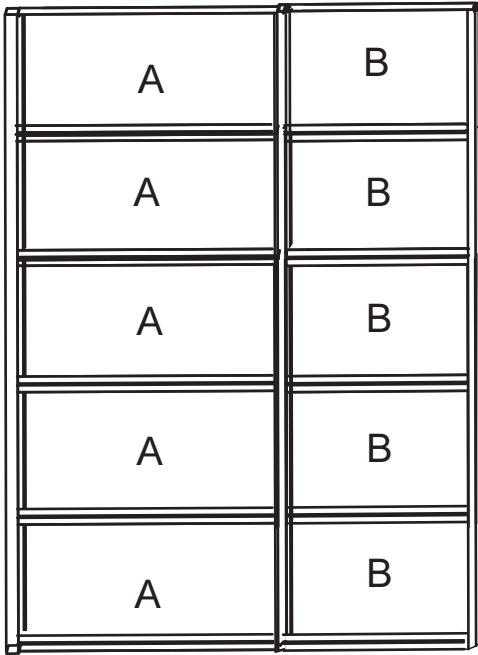
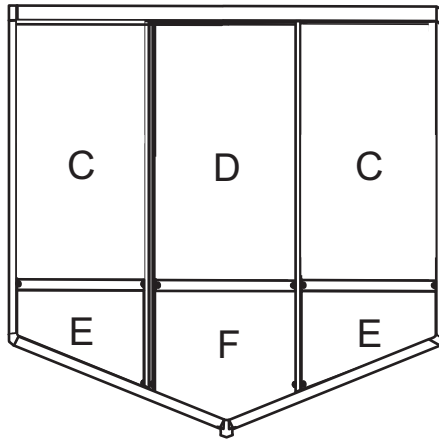

The white film faces outwards if applicable.

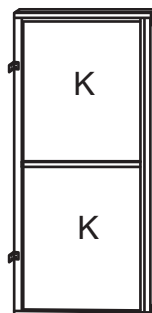
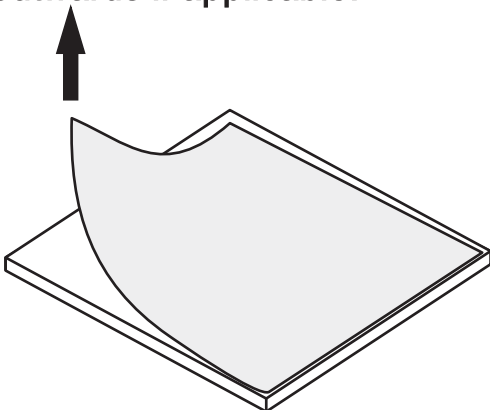

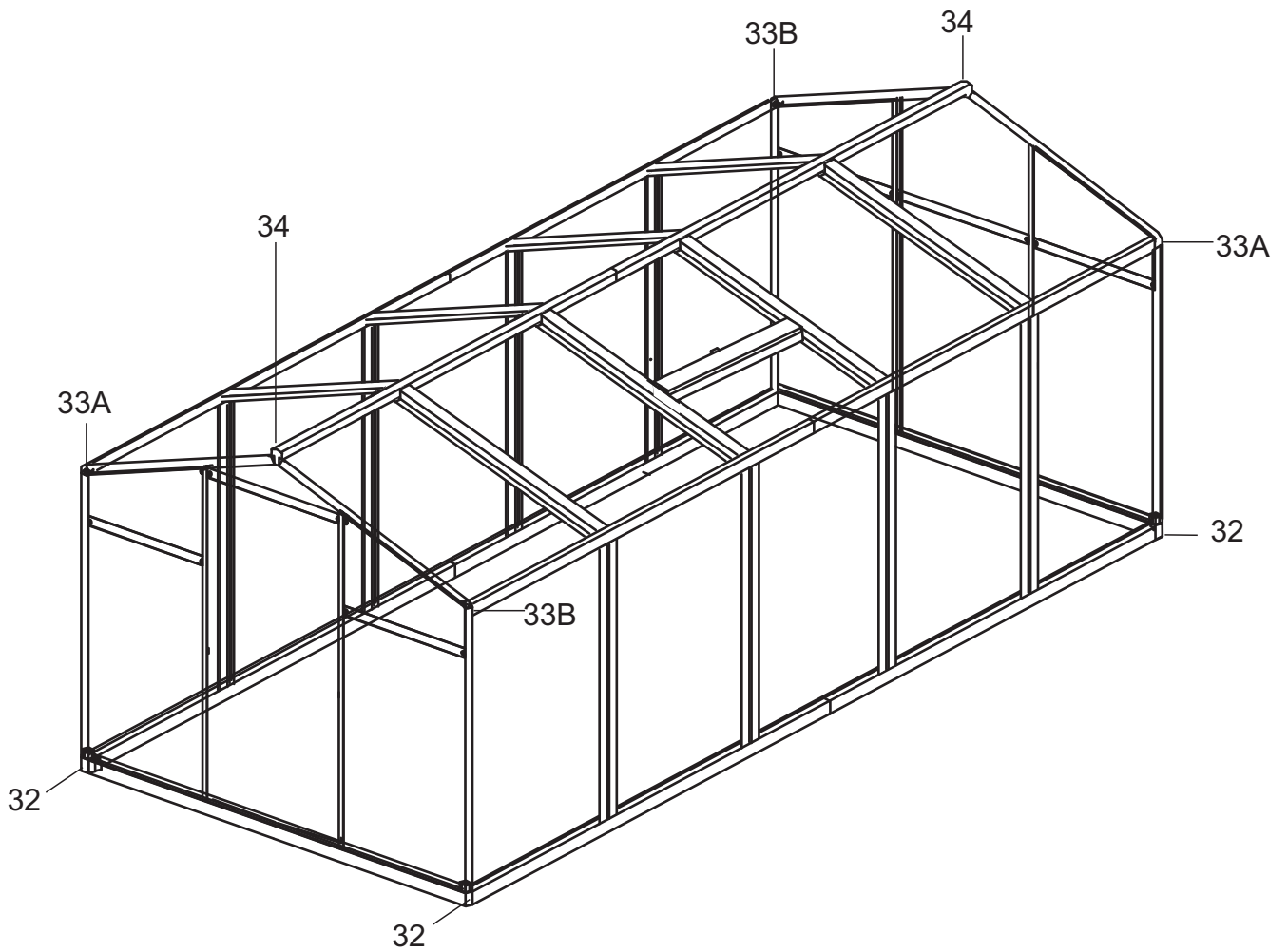
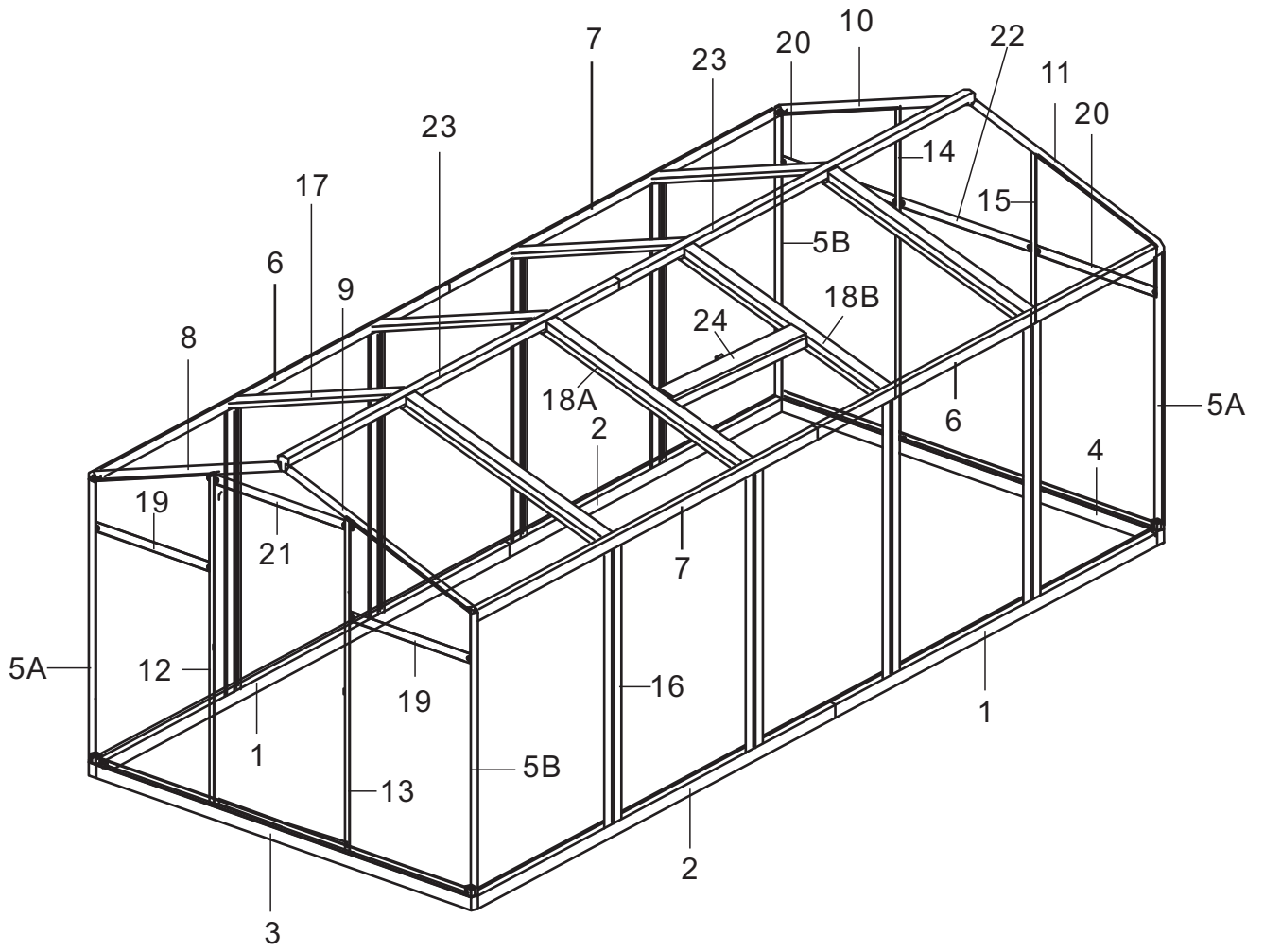

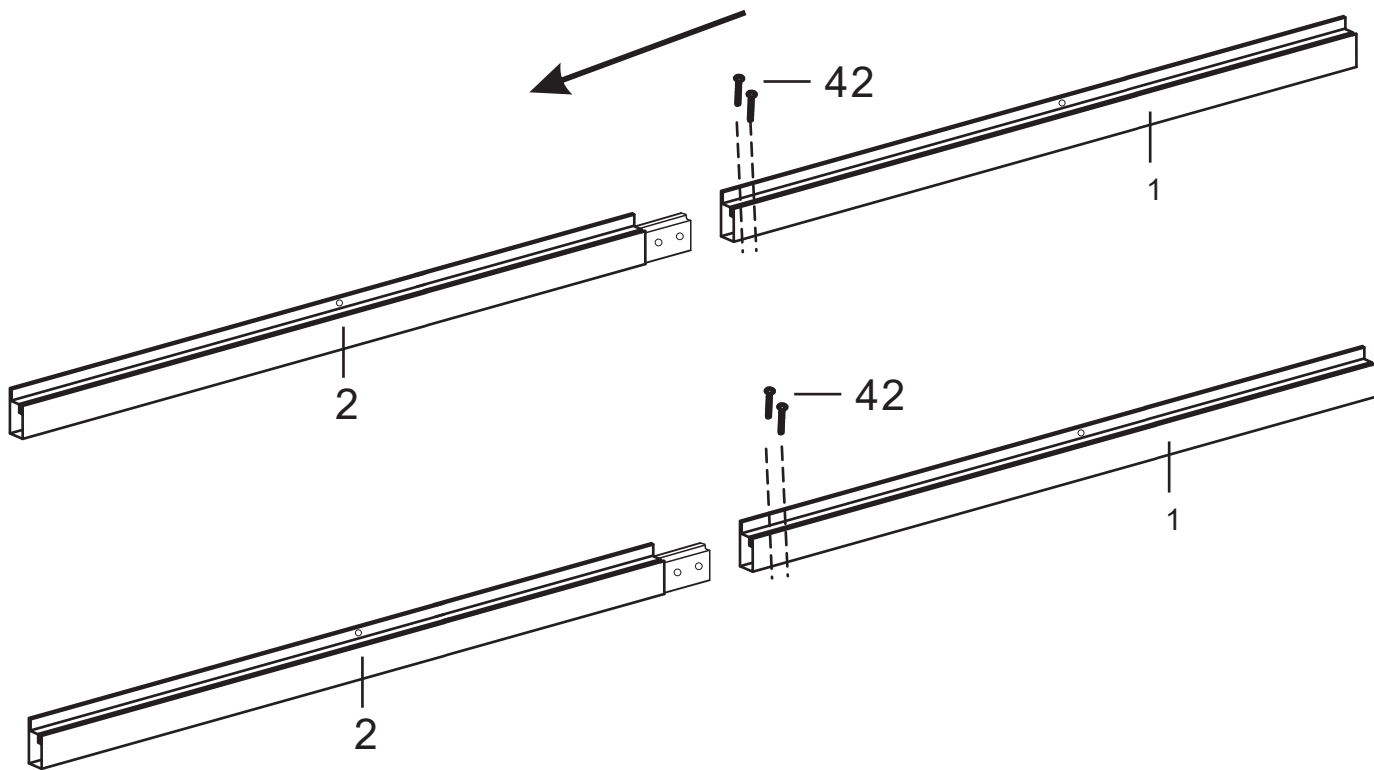

| Picture | NO. | Qty. |
|---------|-----|------|
|         | 1   | 2    |
|         | 2   | 2    |
|         | 42  | 4    |

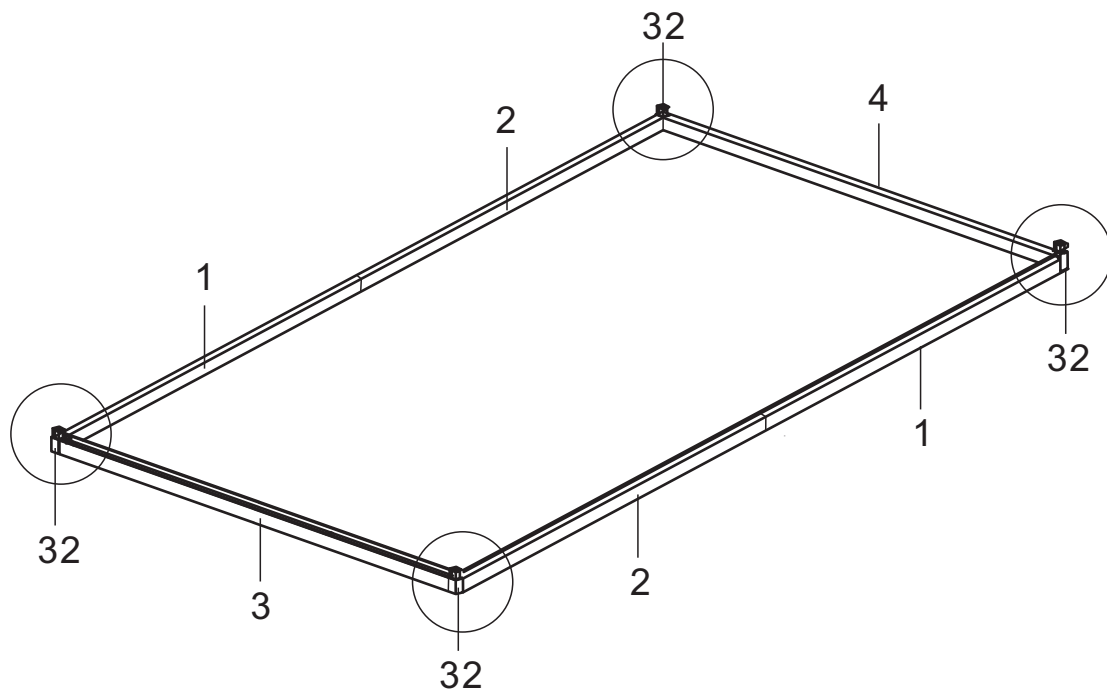

| Picture | NO. | Qty. |
|---------|-----|------|
|         | 3   | 1    |
|         | 4   | 1    |
|         | 32  | 4    |
|         | 42  | 8    |

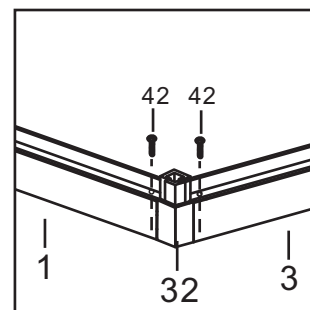
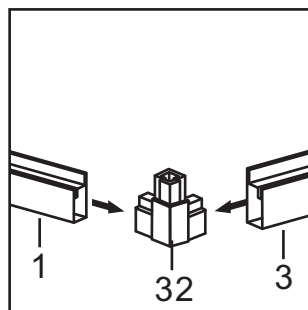



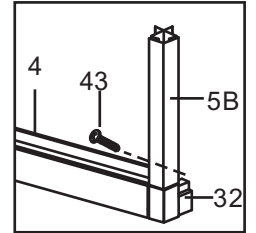
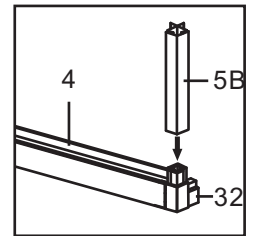
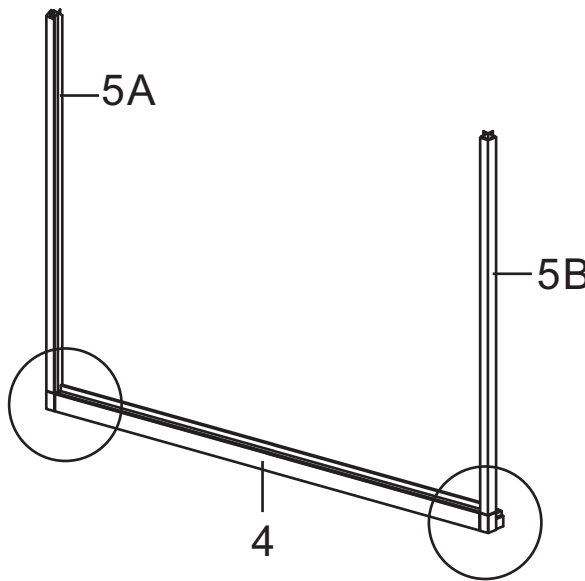
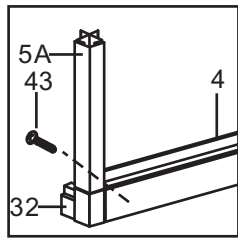
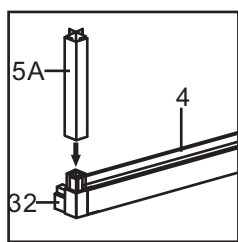
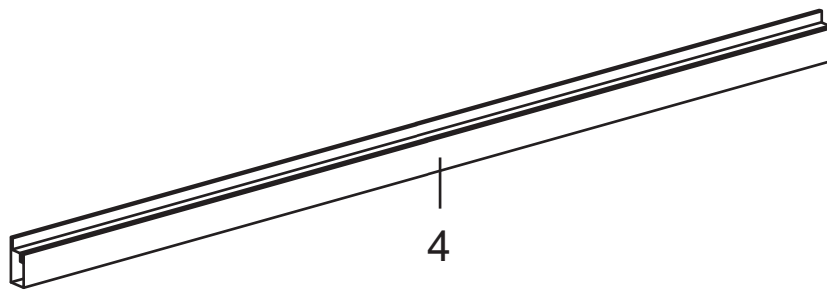



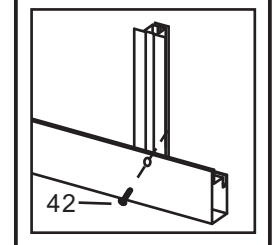
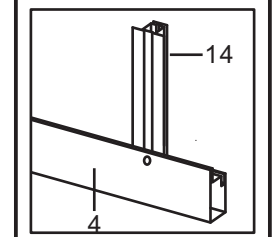
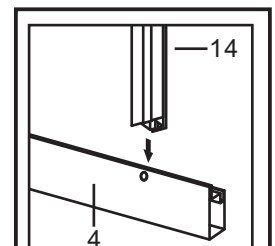
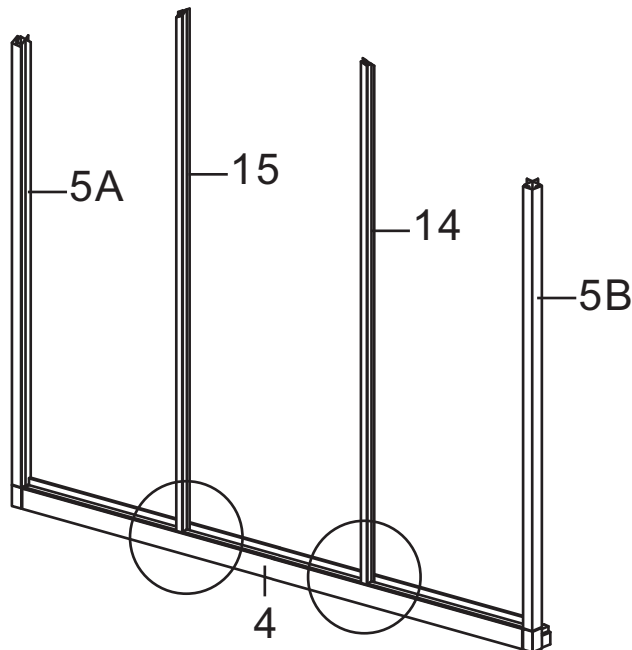

| Picture | NO. | Qty. |
|---------|-----|------|
|         | 5A  | 1    |
|         | 5B  | 1    |
|         | 43  | 2    |





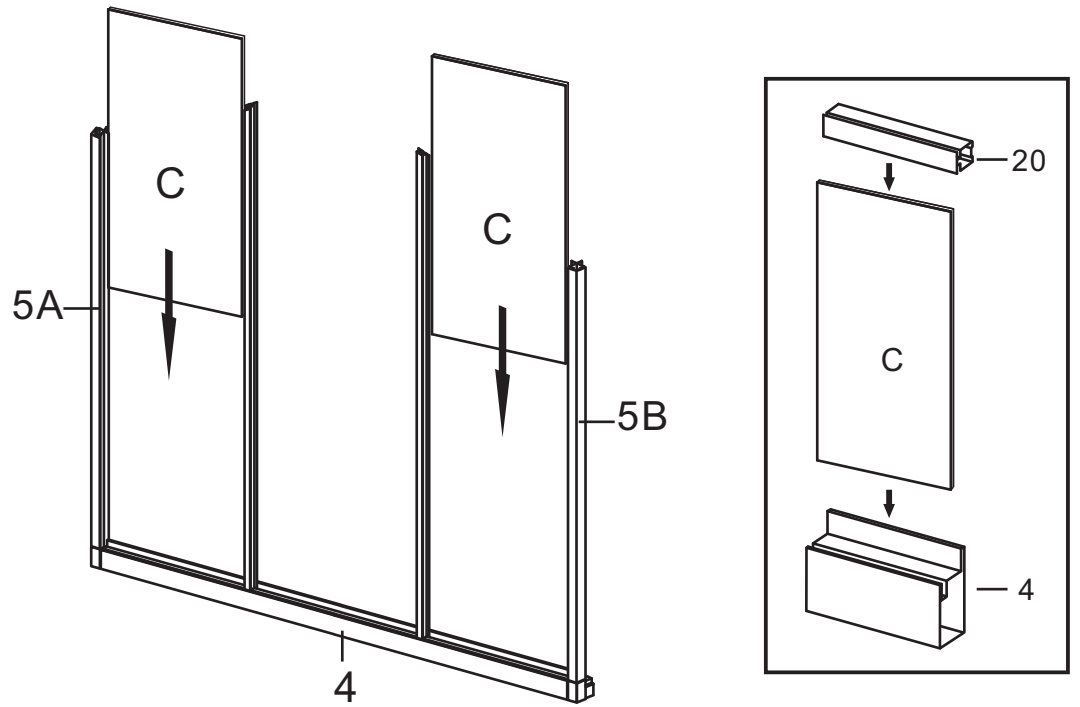

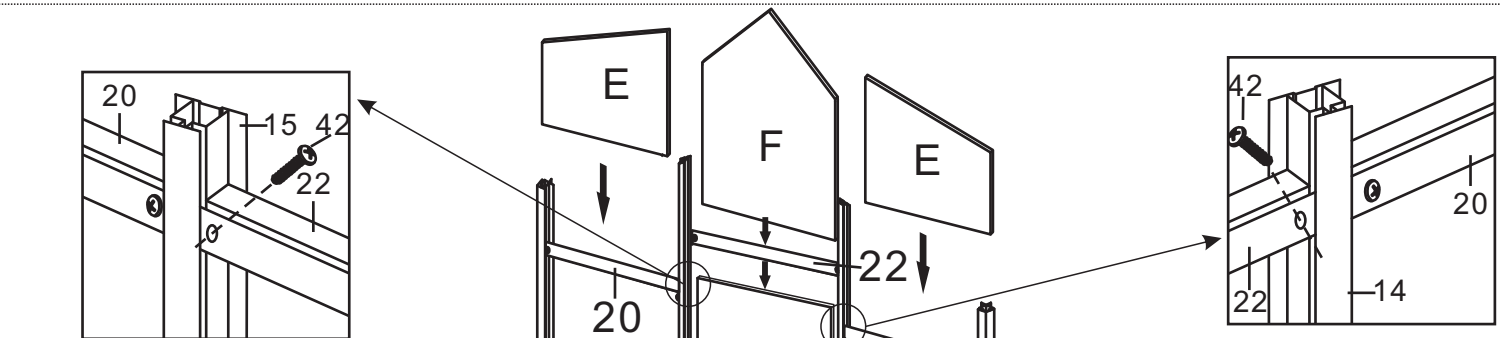
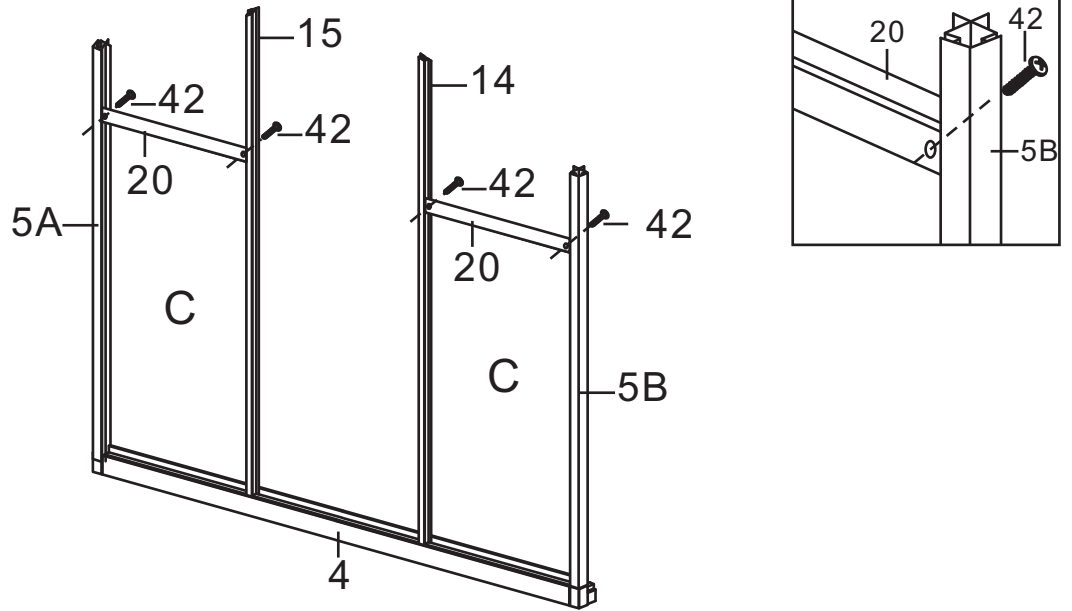

| Picture | NO. | Qty. |
|---------|-----|------|
|         | 14  | 1    |
|         | 15  |      |
|         | 42  | 2    |

| Picture  | NO. | Qty. |
|--|-----|------|
|  | C   | 2    |
|  | 20  | 2    |



| Picture  | NO. | Qty. |
|--|-----|------|
|  | 42  | 4    |



| Picture  | NO. | Qty. |
|--|-----|------|
|  | D   | 1    |
|  | F   | 1    |
|  | E   | 2    |
|  | 22  | 1    |
|  | 42  | 2    |

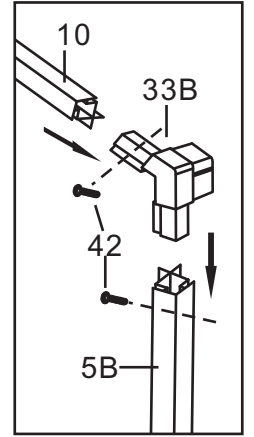
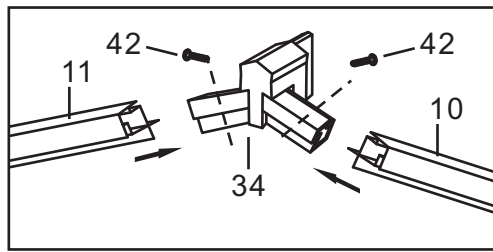
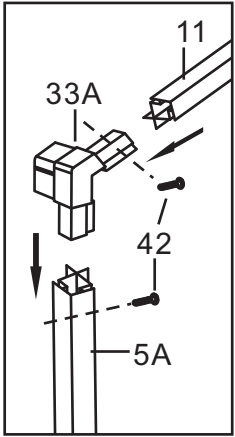

| Picture | NO. | Qty. |
|---------|-----|------|
|         | 10  | 1    |
|         | 11  | 1    |
|         | 34  | 1    |
|         | 33A | 1    |
|         | 33B | 1    |
|         | 42  | 6    |

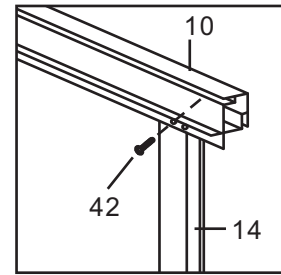
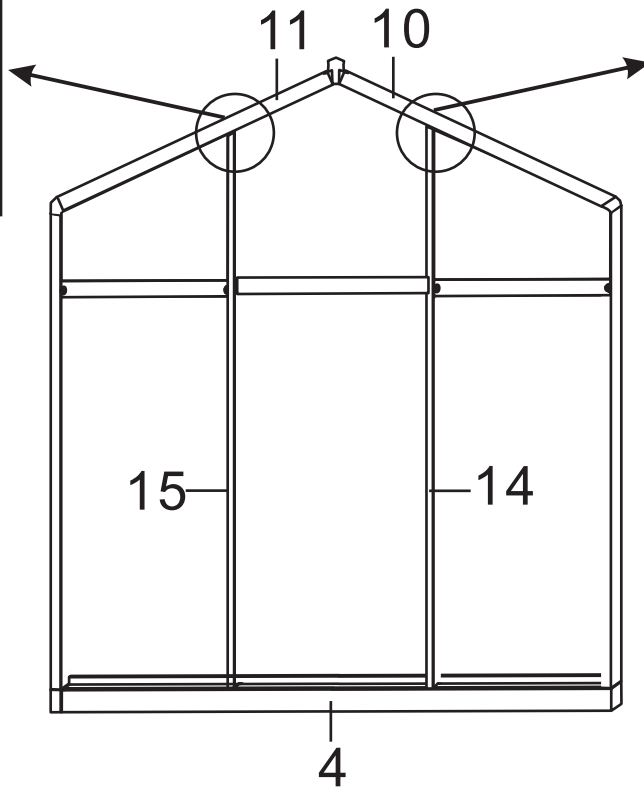
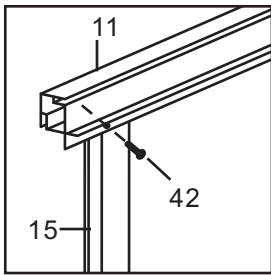
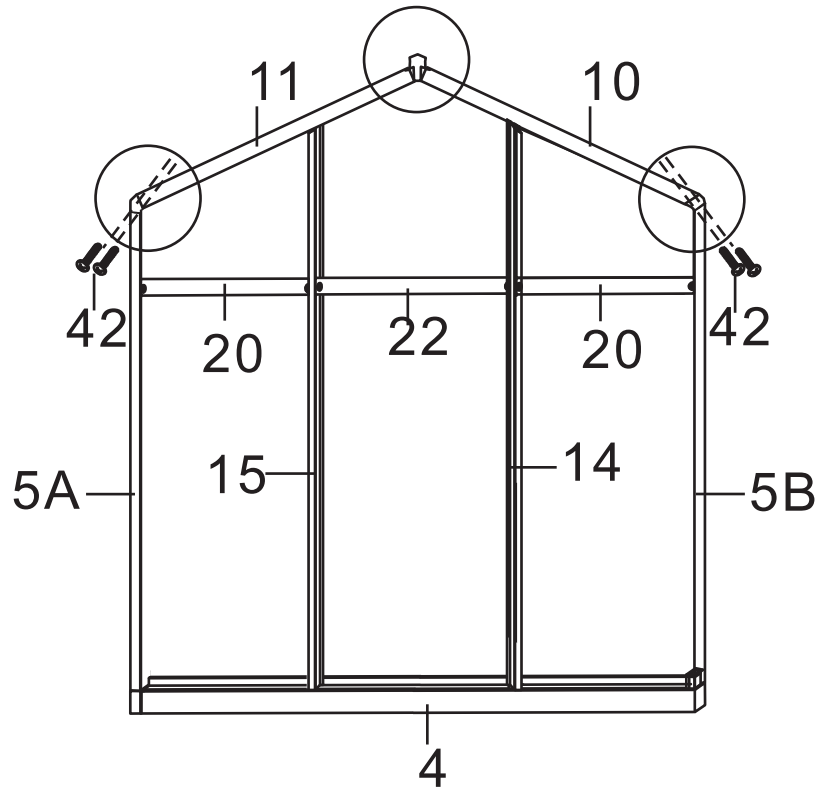

| Picture | NO. | Qty. |
|---------|-----|------|
|         | 42  | 2    |

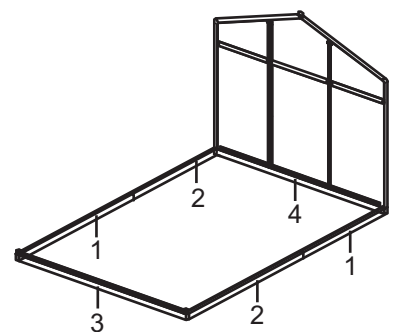

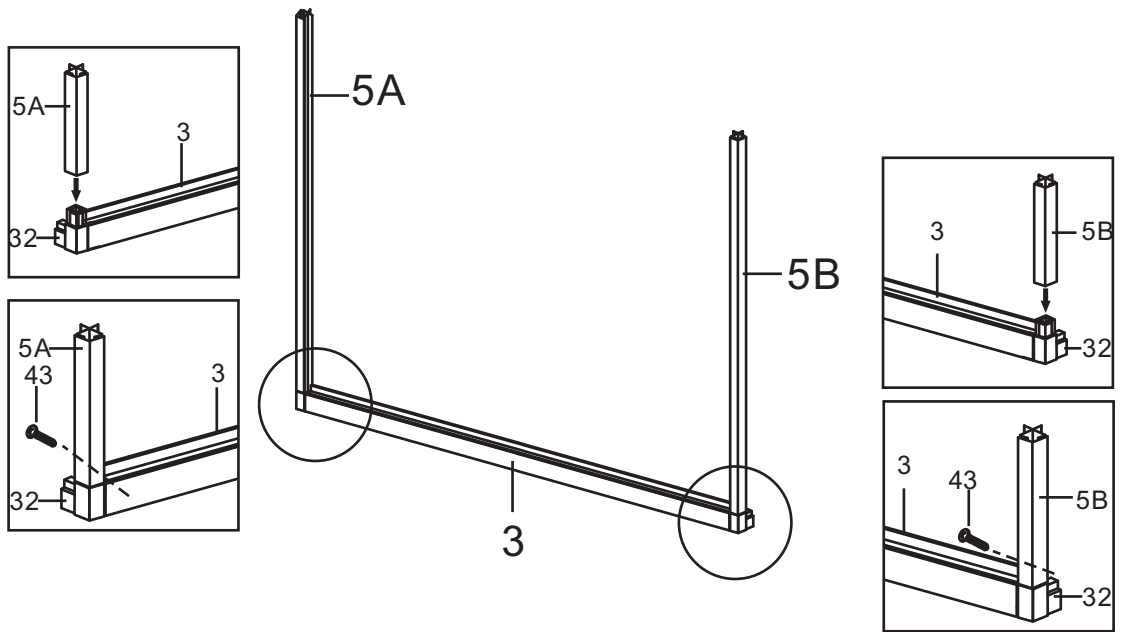
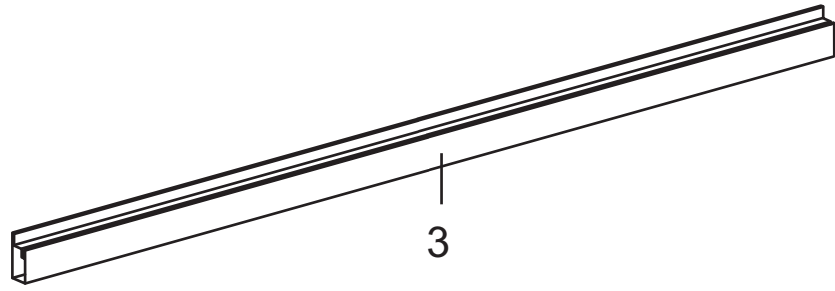

| Picture | NO. | Qty. |
|---------|-----|------|
|         | 5A  | 1    |
|         | 5B  | 1    |
|         | 43  | 2    |

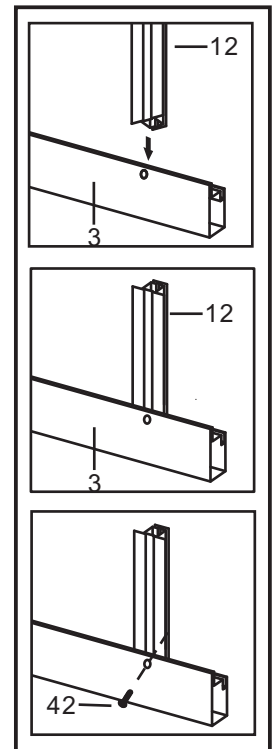
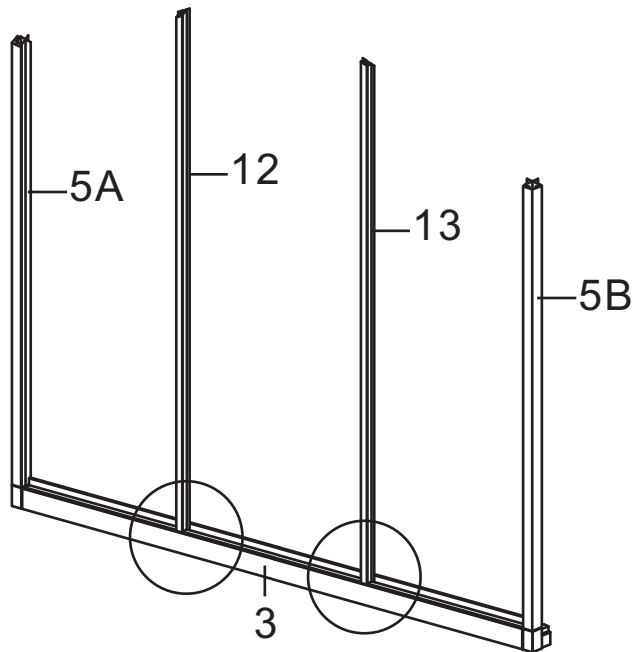

| Picture | NO. | Qty. |
|---------|-----|------|
|         | 12  | 1    |
|         | 13  |      |
|         | 42  | 2    |

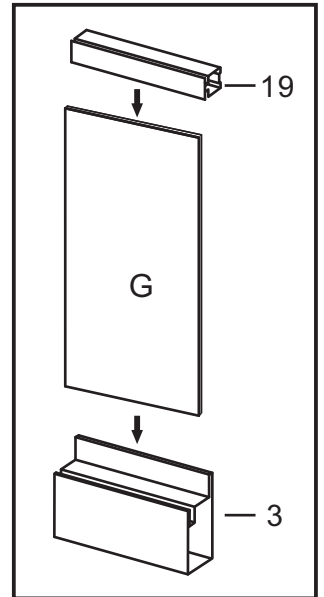
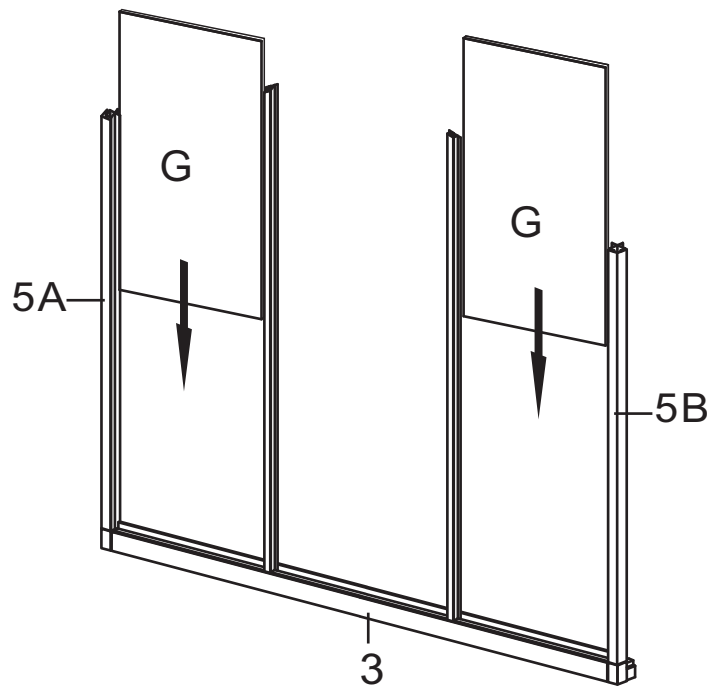

| Picture | NO. | Qty. |
|---------|-----|------|
|         | G   | 2    |
|         | 19  | 2    |

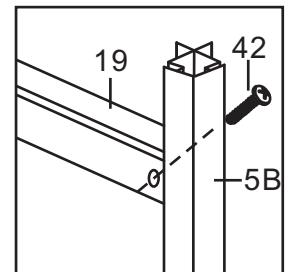
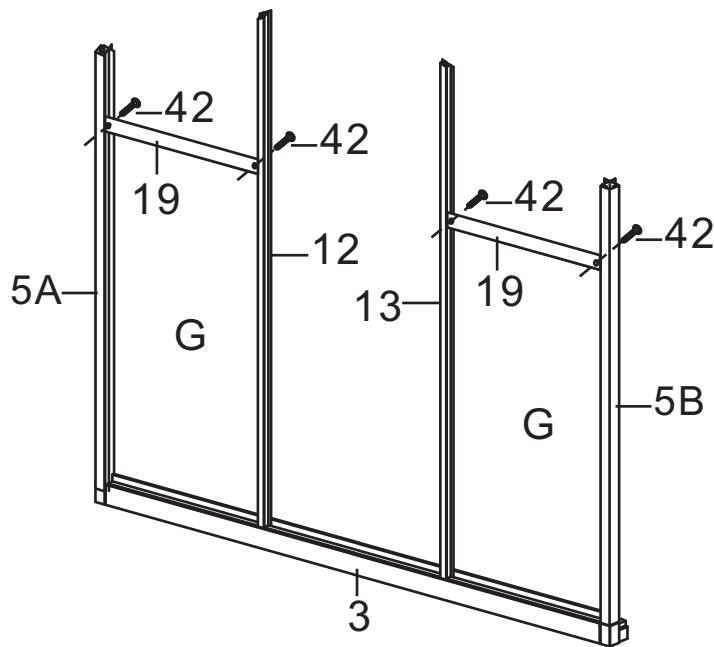

| Picture | NO. | Qty. |
|---------|-----|------|
|         | 42  | 4    |

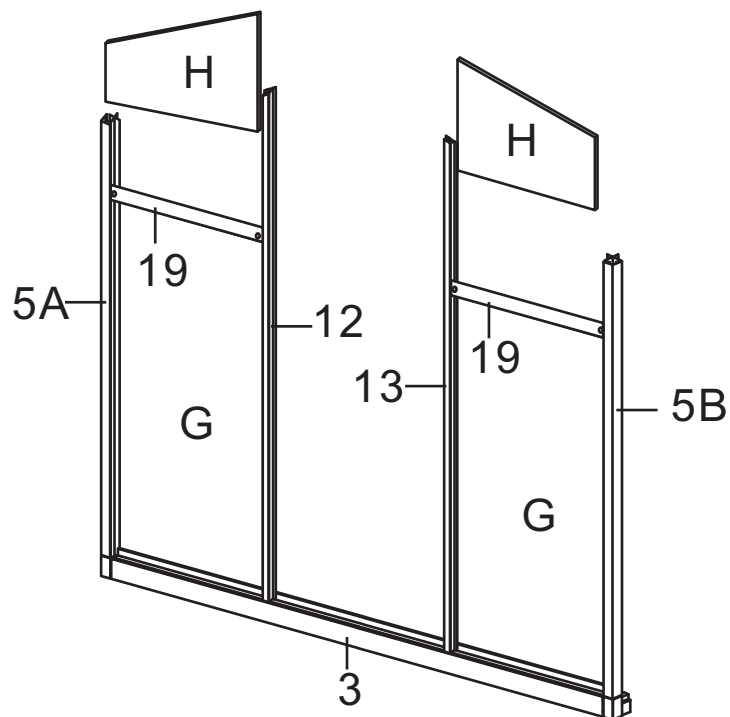

| Picture | NO. | Qty. |
|---------|-----|------|
|         | H   | 2    |

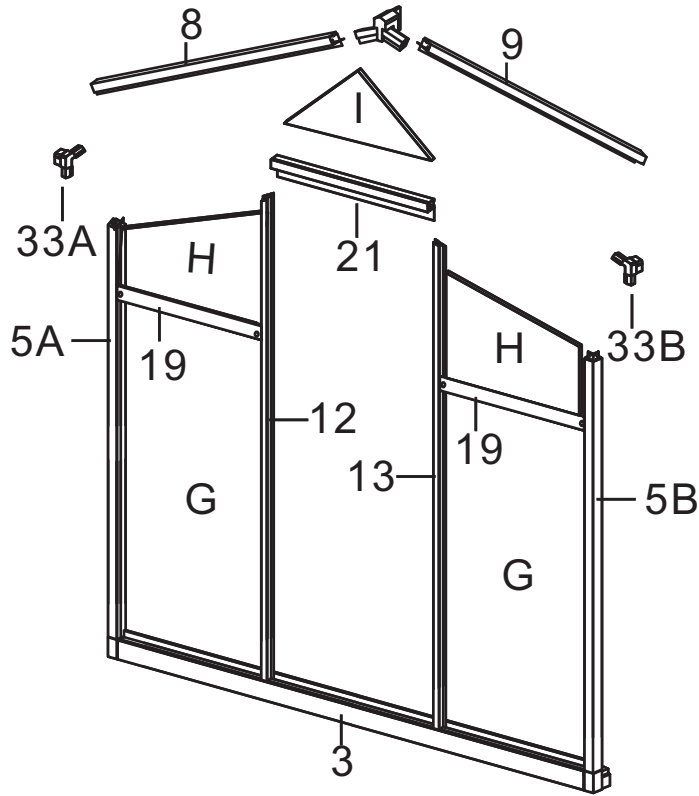
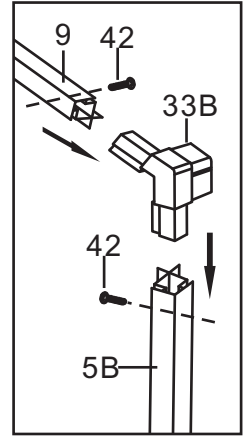
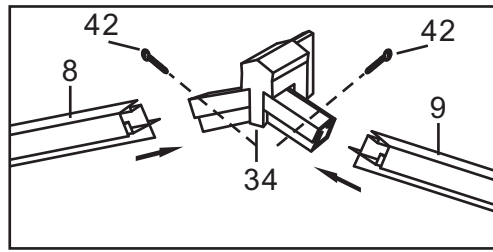
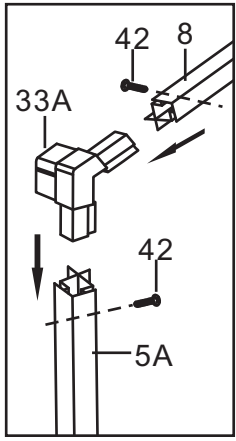

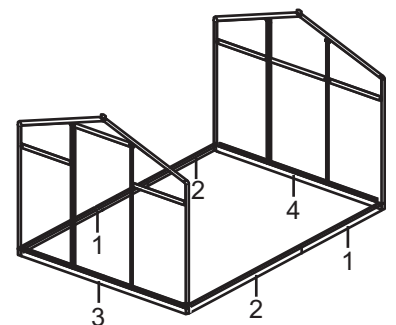
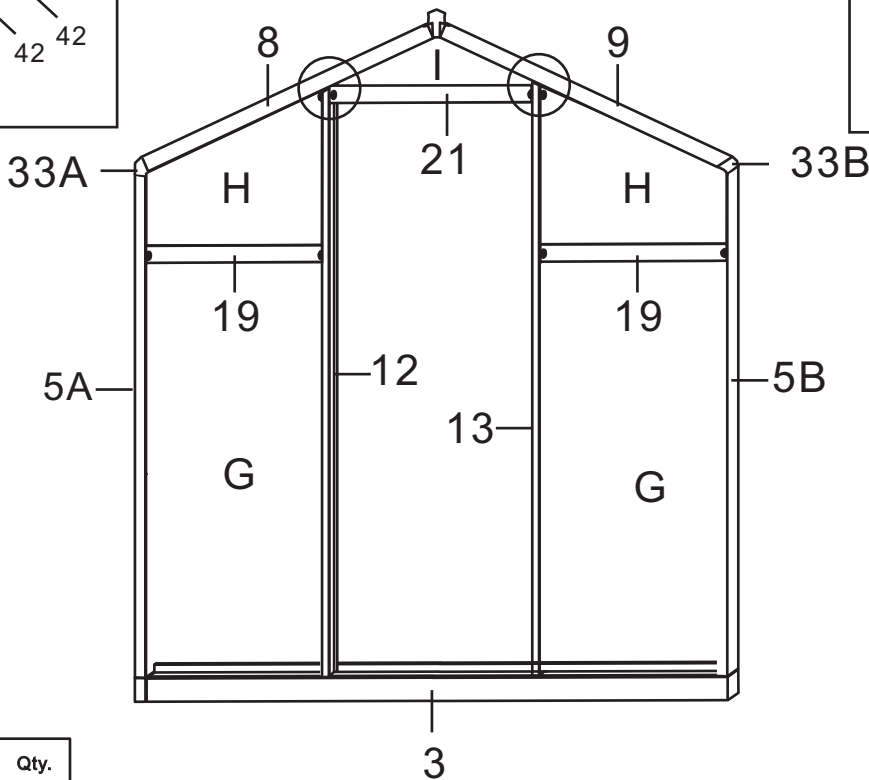
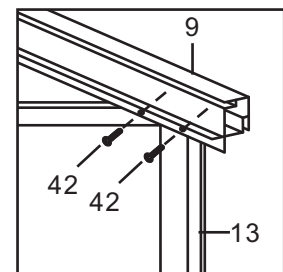
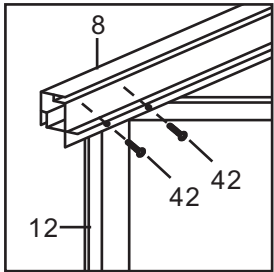

| Picture | NO. | Qty. |
|---------|-----|------|
|         | 8   | 1    |
|         | 9   | 1    |
|         | 21  | 1    |
|         | 33A | 1    |
|         | 33B | 1    |
|         | 34  | 1    |
|         | 42  | 6    |
|         | I   | 1    |

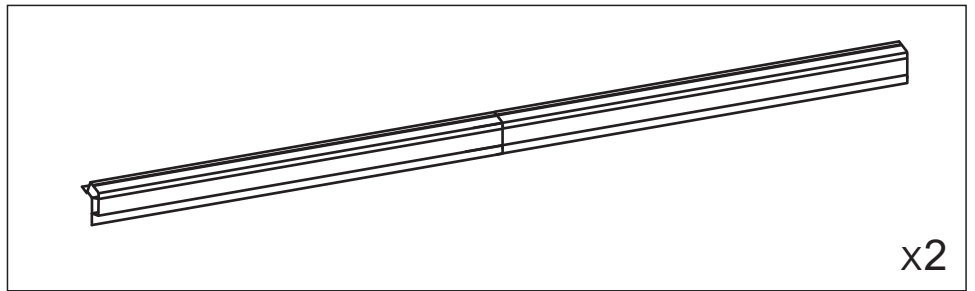
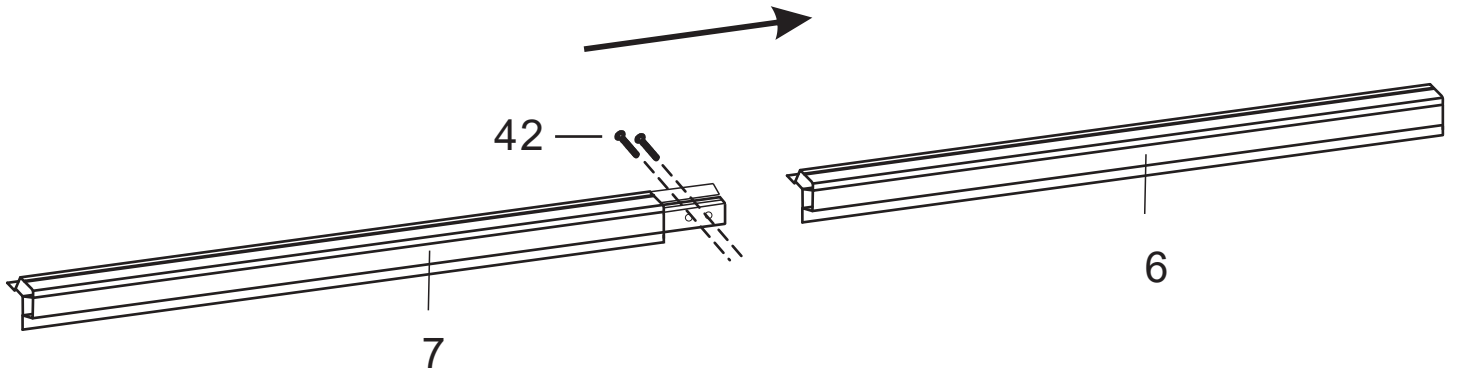

| Picture | NO. | Qty. |
|---------|-----|------|
|         | 42  | 4    |



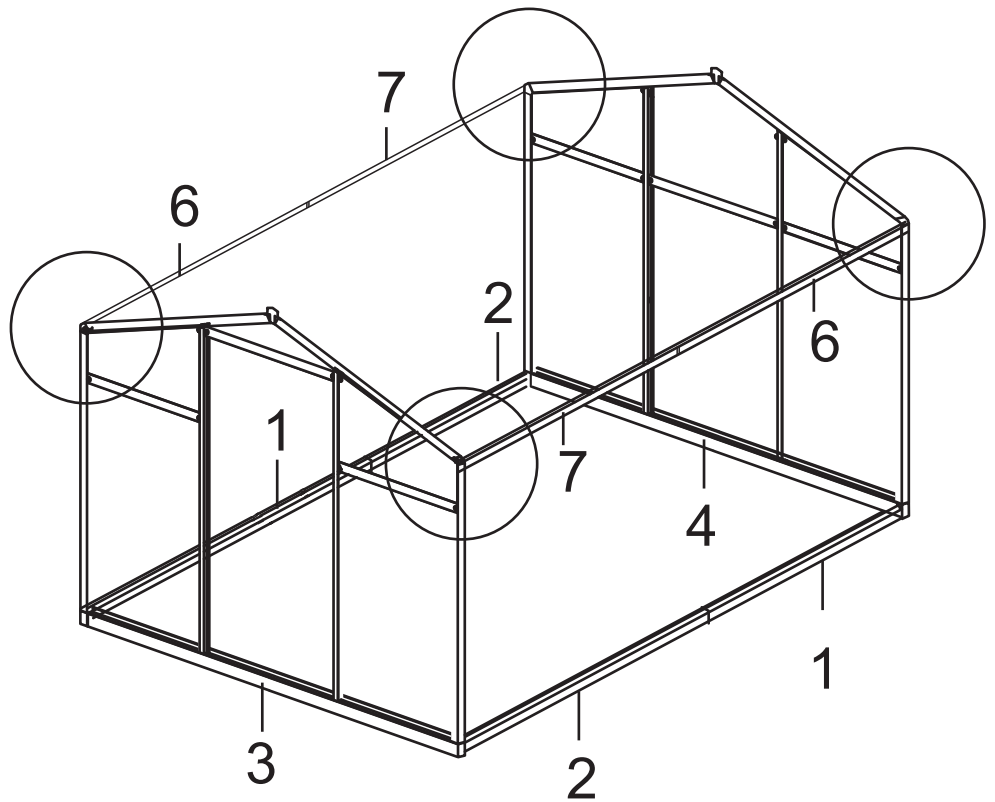
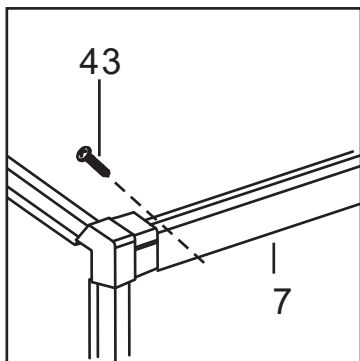
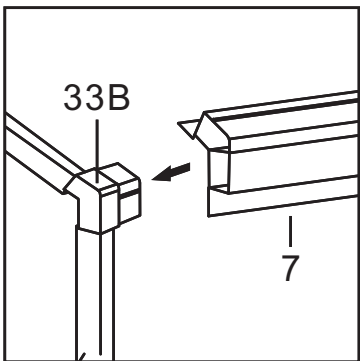

| Picture  | NO. | Qty. |
|--|-----|------|
|   | 6   | 2    |
|   | 7   | 2    |
|  | 42  | 4    |

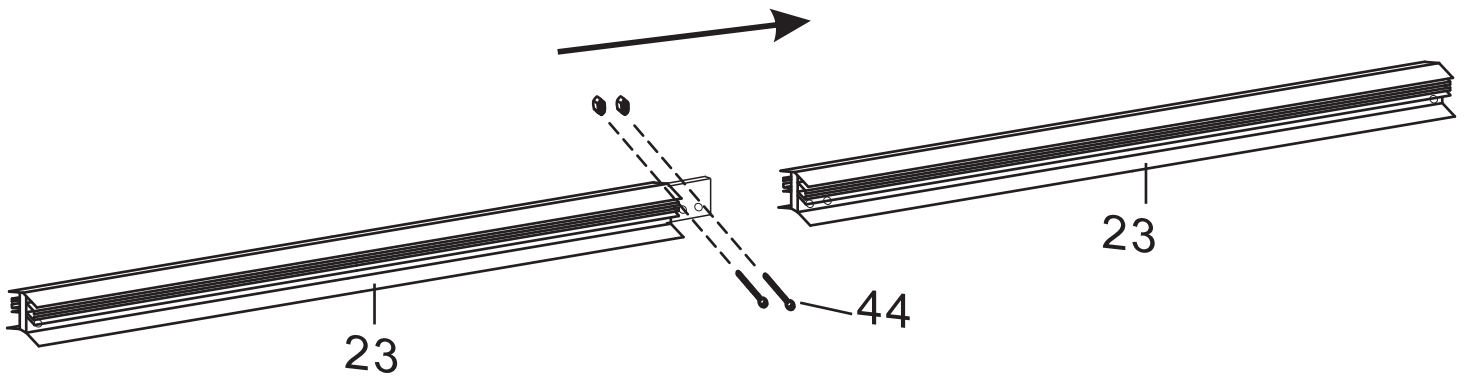

| Picture  | NO. | Qty. |
|--|-----|------|
|  | 43  | 4    |



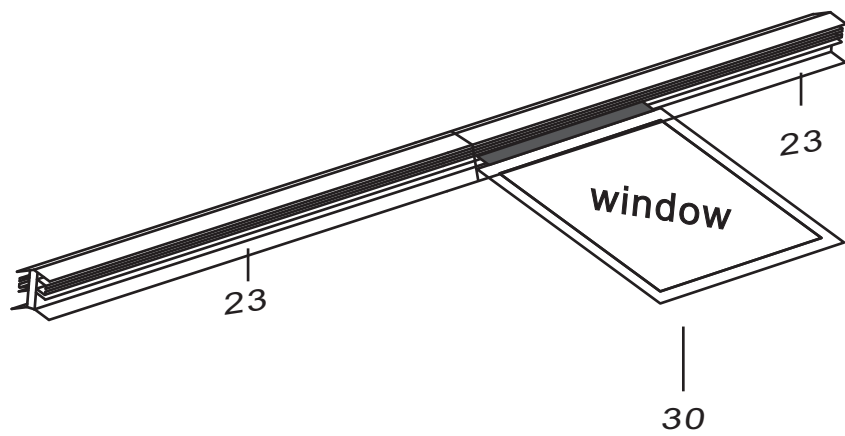
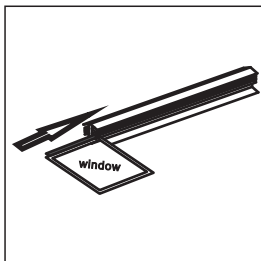
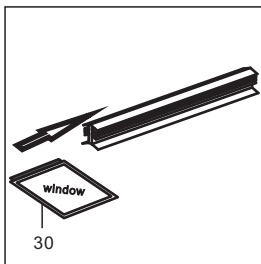

| Picture  | NO. | Qty. |
|--|-----|------|
|   | 23  | 2    |
|  | 44  | 2    |



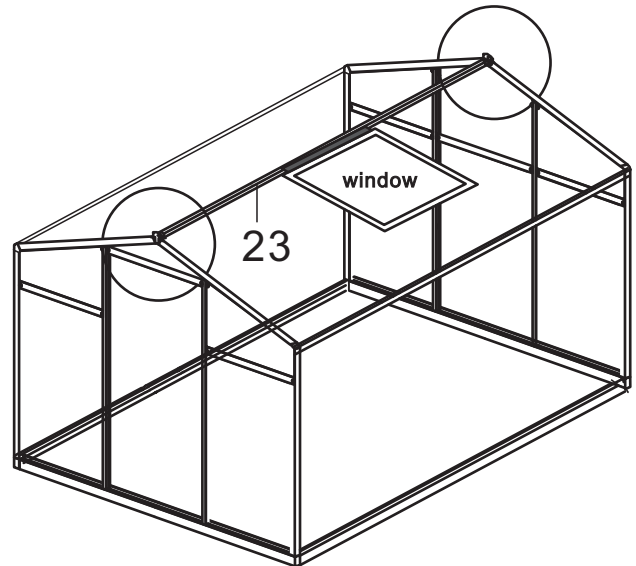
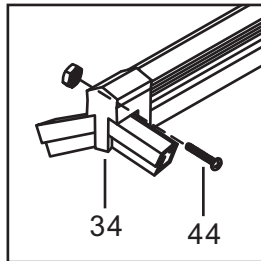
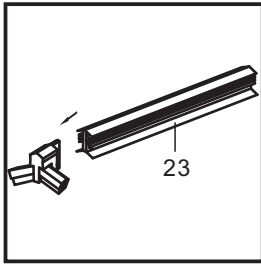

| Picture  | NO. | Qty. |
|--|-----|------|
|  | 30  | 1    |



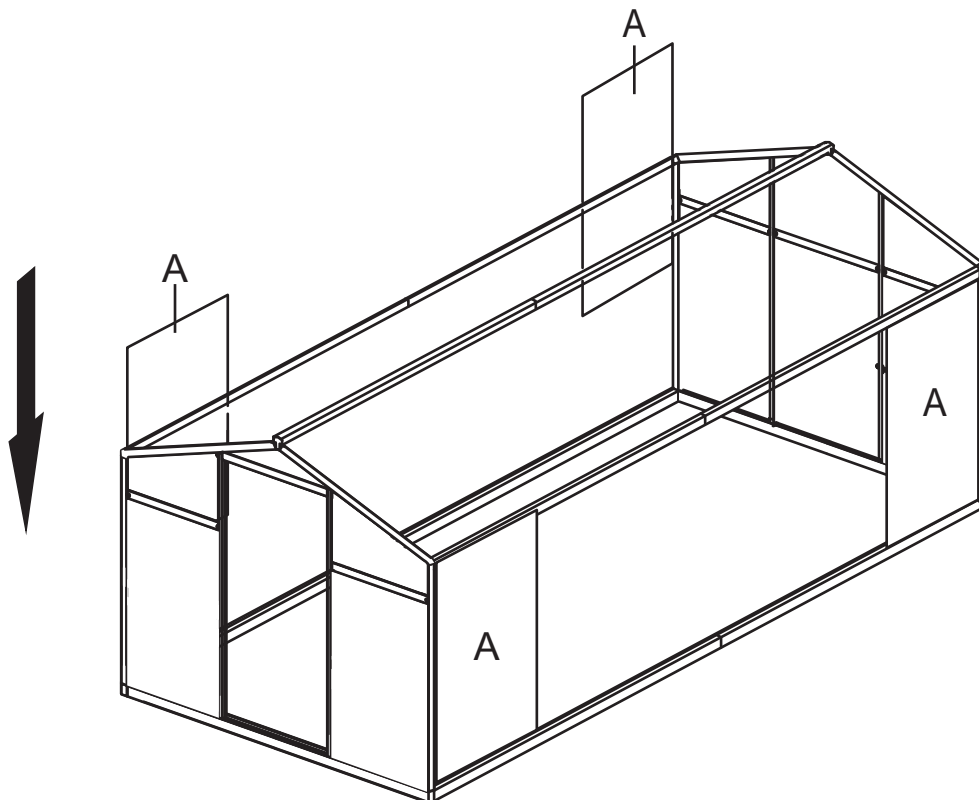

| Picture  | NO. | Qty. |
|--|-----|------|
|  | 44  | 2    |



| Picture  | NO. | Qty. |
|--|-----|------|
|  | A   | 4    |

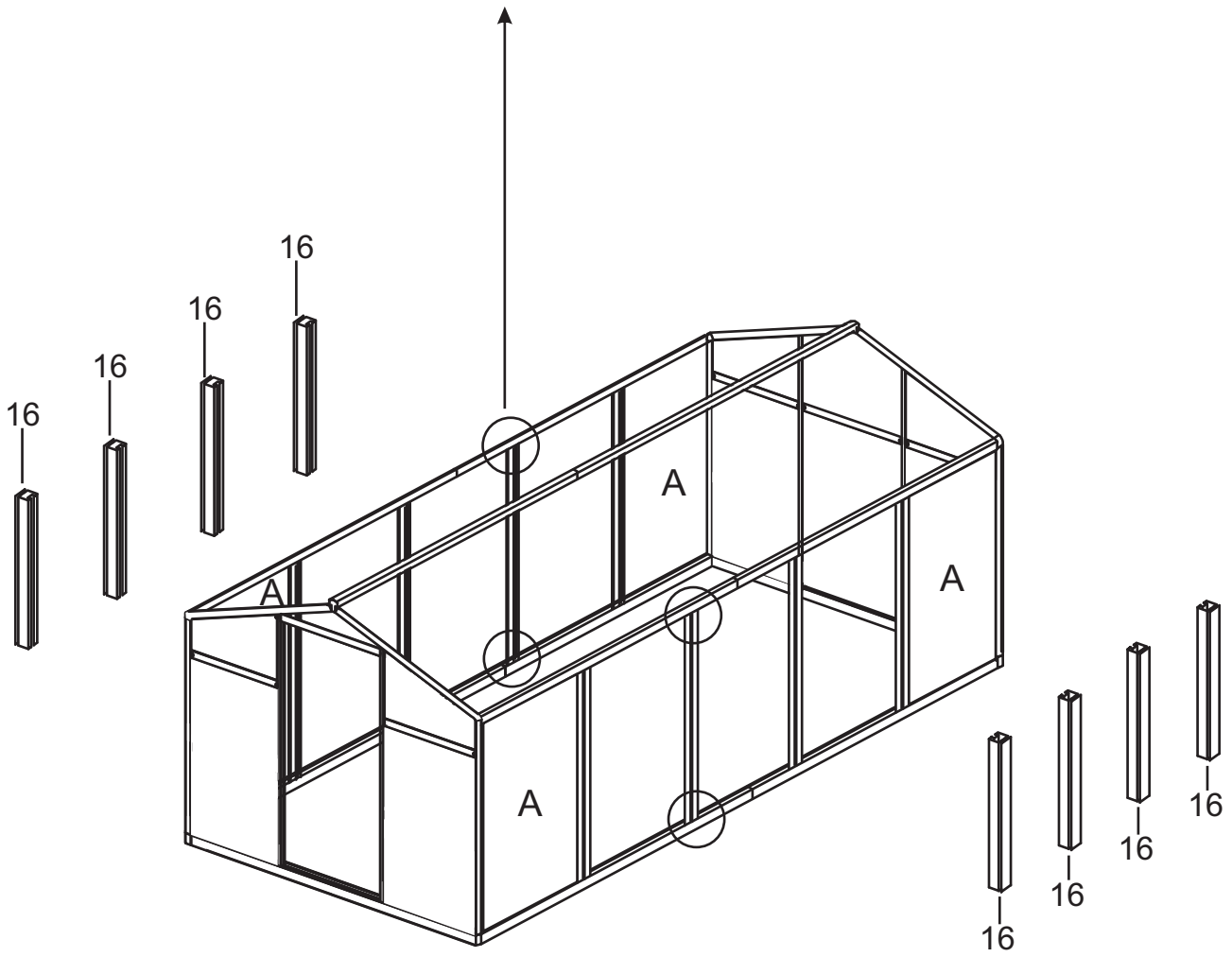
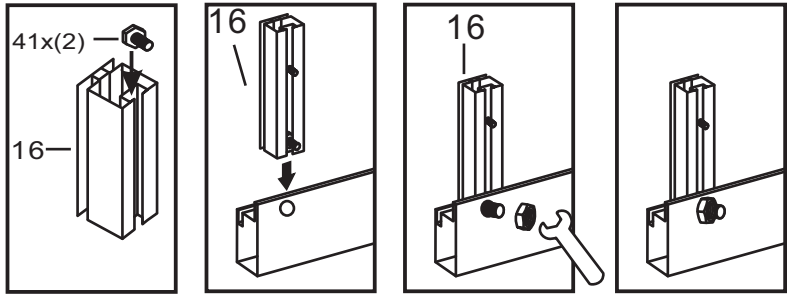

| Picture | NO. | Qty. |
|---------|-----|------|
|         | 16  | 8    |
|         | 41  | 16   |

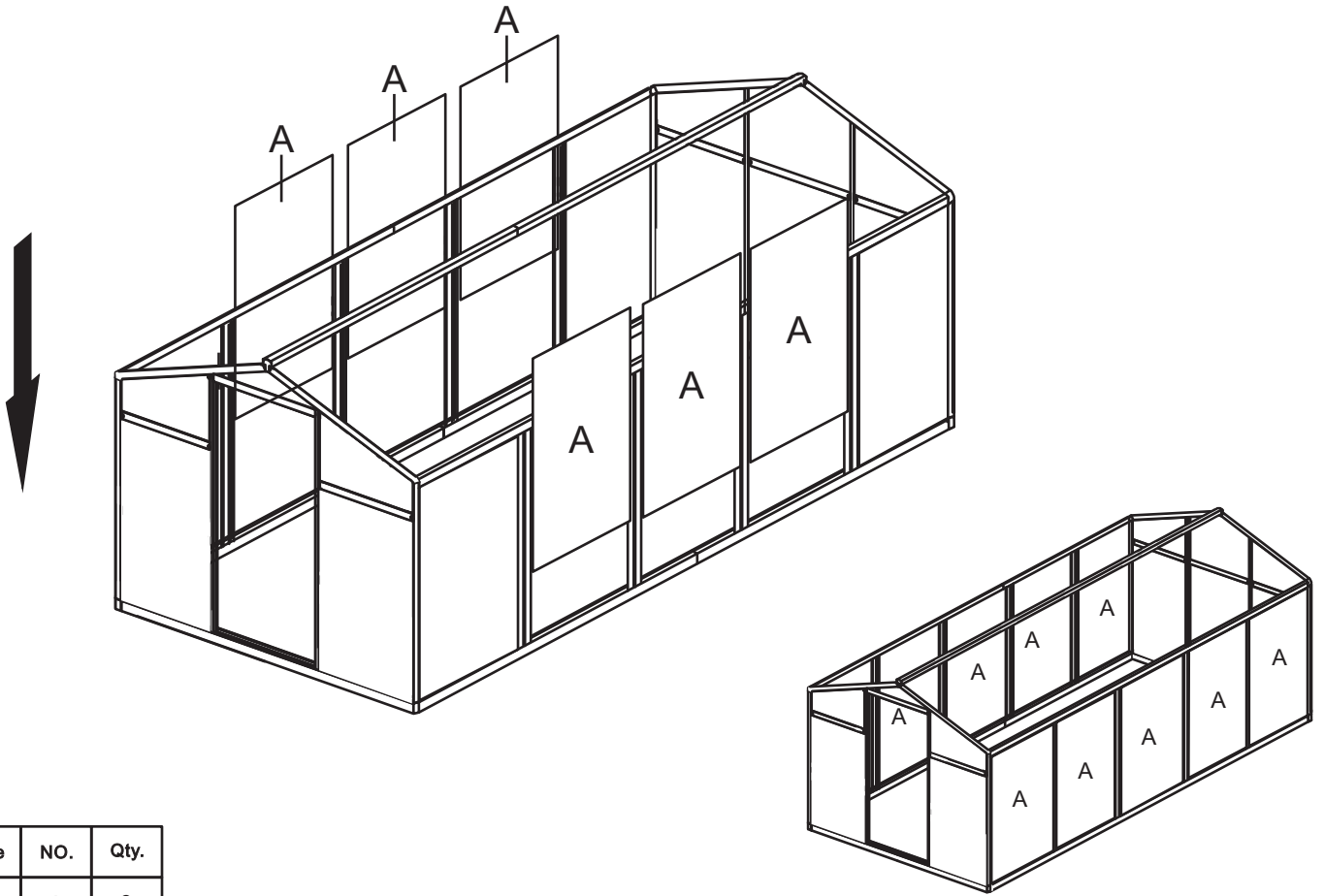

| Picture  | NO. | Qty. |
|--|-----|------|
|  | A   | 6    |

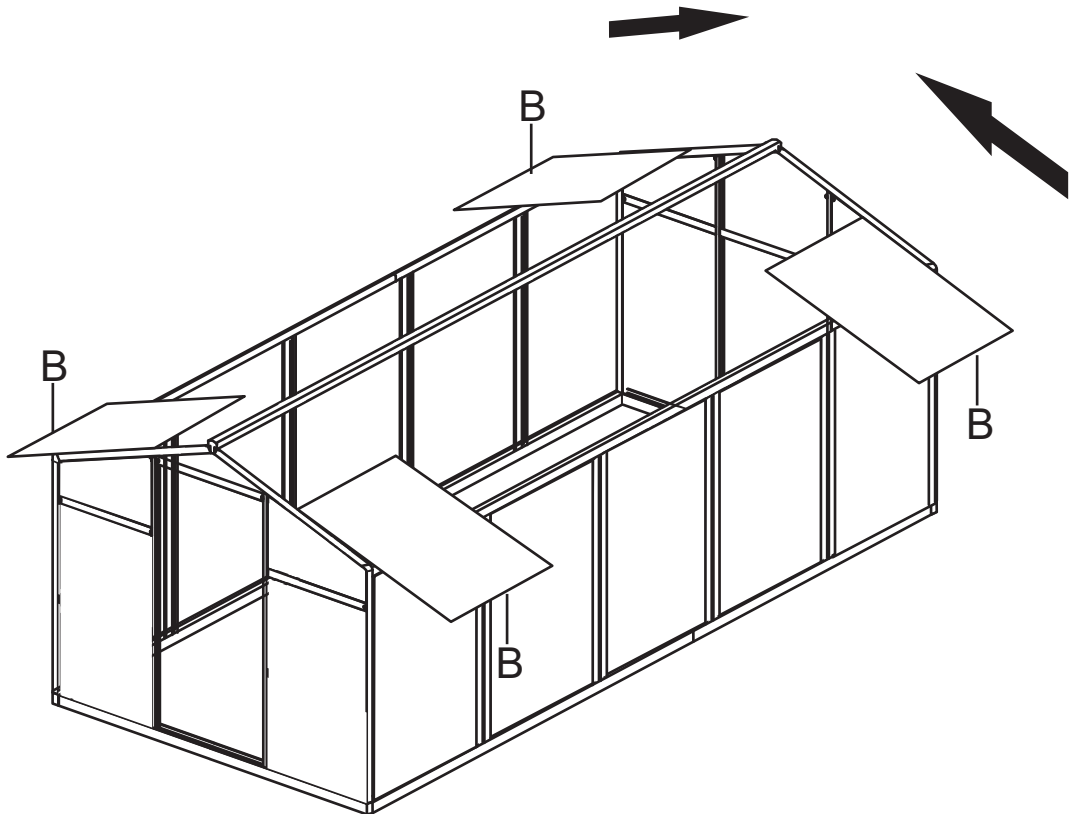

| Picture  | NO. | Qty. |
|--|-----|------|
|  | B   | 4    |

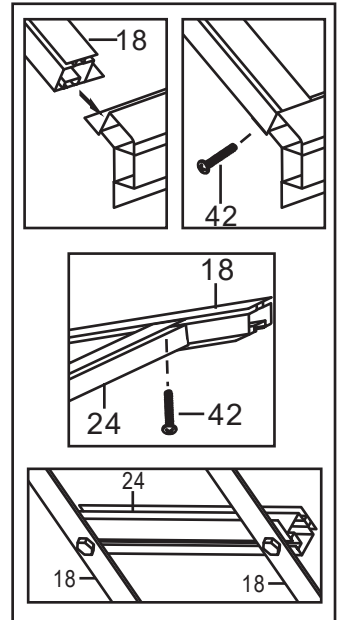
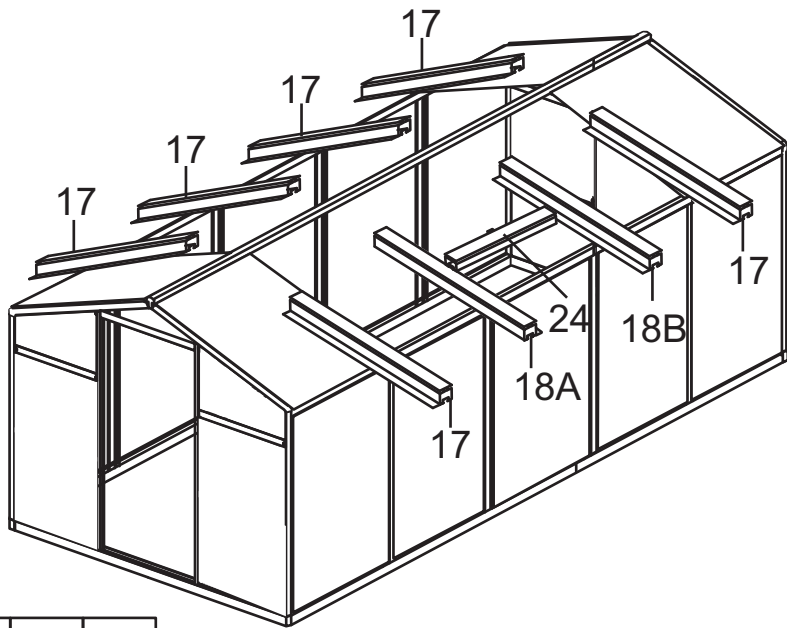

| Picture | NO. | Qty. |
|---------|-----|------|
|         | 17  | 6    |
|         | 18A | 1    |
|         | 18B | 1    |
|         | 24  | 1    |
|         | 41  | 12   |
|         | 42  | 6    |

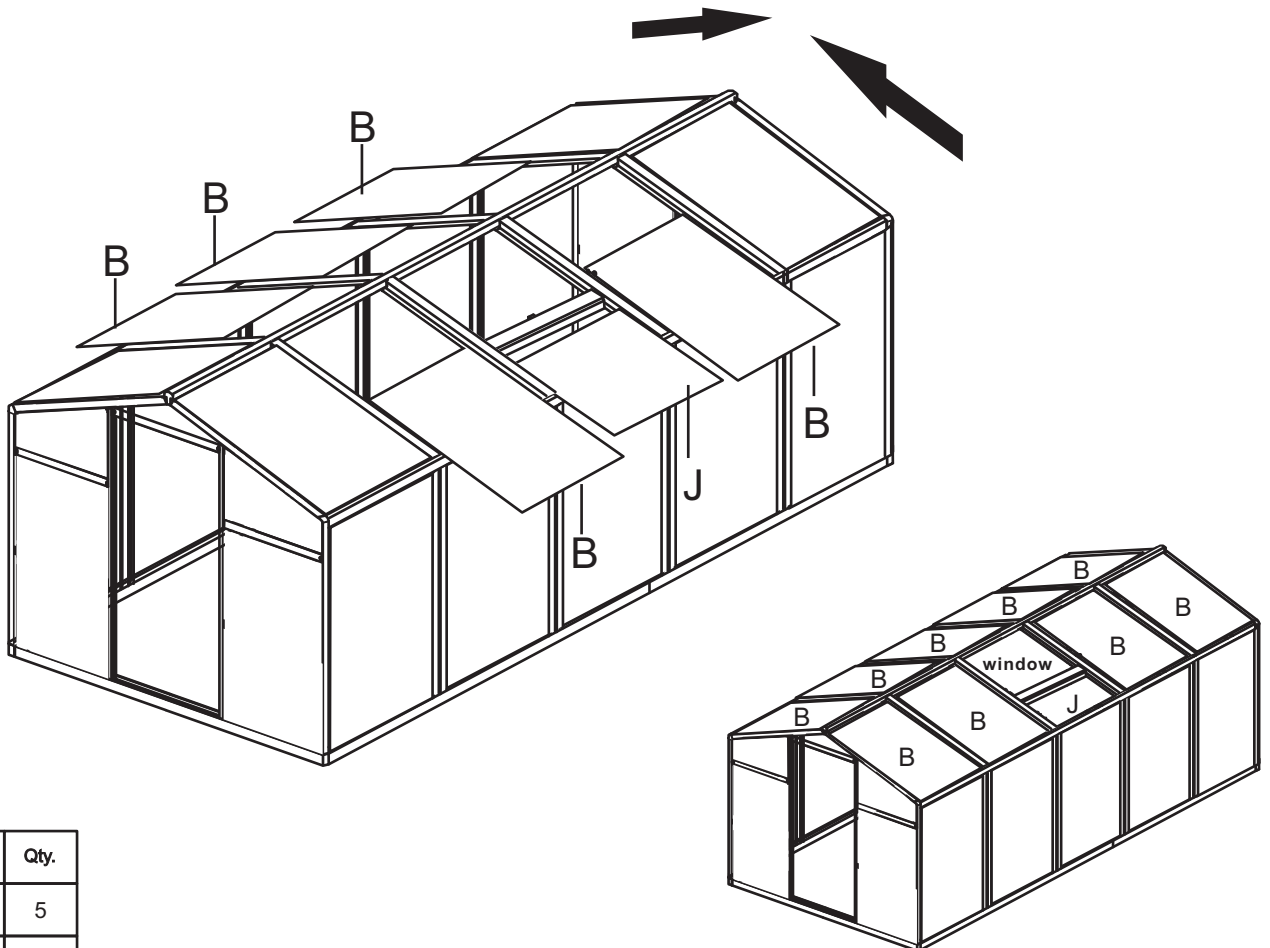
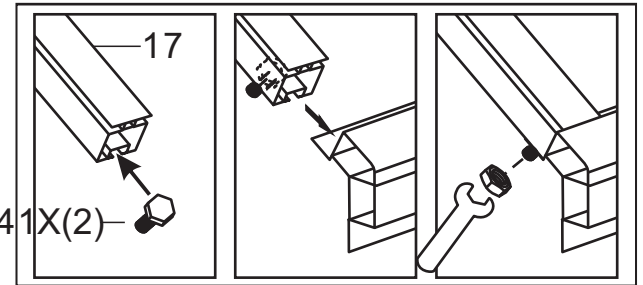

| Picture | NO. | Qty. |
|---------|-----|------|
|         | B   | 5    |
|         | J   | 1    |

