









PART LIST

- | | | | |
|---|---|---|--|
| 1 TOP STRAIGHT POLE X 4 | 2 TOP CURVE POLE X 2 | 3 BACK STRAIGHT POLE X 2 | 4 STRAIGHT POLE X 2 |
|  |  |  |  |
| 5 SHORT STRAIGHT POLE X 2 | 6 SIDE BOTTOM END POLE X 2 | 7 ELBOW JOINT X 6 | 8 BACK SIDE STRAIGHT JOINT X 2 |
|  |  |  |  |
| 9 FRONT FRAME STRAIGHT JOINT X 2 | | | |
|  | | | |

ACCESSORY PACK

NET X 1

GROUND PEGS X 6

PLASTIC HOOK X 24

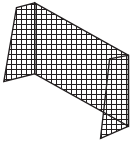

• Refer to Part Numbers and be sure all parts are included

STEP 1: PUSH BUTTON FITTING



STEP 2: RED TABS



STEP 3: HOOK

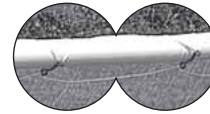

STEP 4: PEGS



STEP

1. Open all packaging and organise all poles into number groups. Each part will have a number sticker matching the parts list above.
2. Connect the numbered poles together as shown in the diagram. Ensure the push-button on Joint 7 is located and locked into the holes in Poles 1,4 for a firm fixing (Step 1). Repeat Step 1 on the joint 7 in Poles 1,4,5,6 for a firm fixing. And then place the support Poles 2,3 into the holes of joint 7.
3. Ensure all straight joint fittings are aligned and locked in position.
4. Ideally, two people should remove the net from bag, unravel and open fully before fitting. Put the net over the frame with the red tabs (Step 2) in the top left and right-hand corners once assembled.
5. The seam of the net should follow the frame supports. Secure the net to the frame using the plastic hooks ensuring you space them out evenly over the whole frame (Step 3).
6. Once fully assembled and for use on soft ground/grass only. Locate the ground Pegs to fix underground for added strength and stability (Step 4).

CAUTION:

Check regularly that pegs are secure. Loose pegs may cause injury. Care should be taken when using a mallet as misuse may cause injury.

