

DEMAR *mk*

WR35 - Volkswagen Transporter T5 Shelving unit

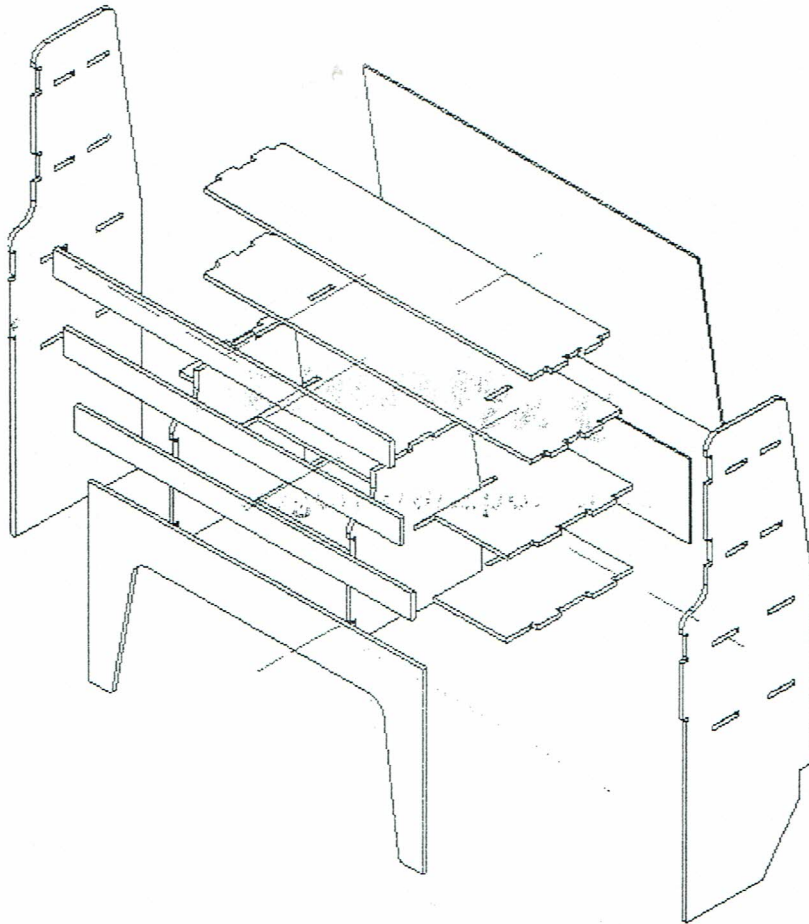

Assembly Procedure

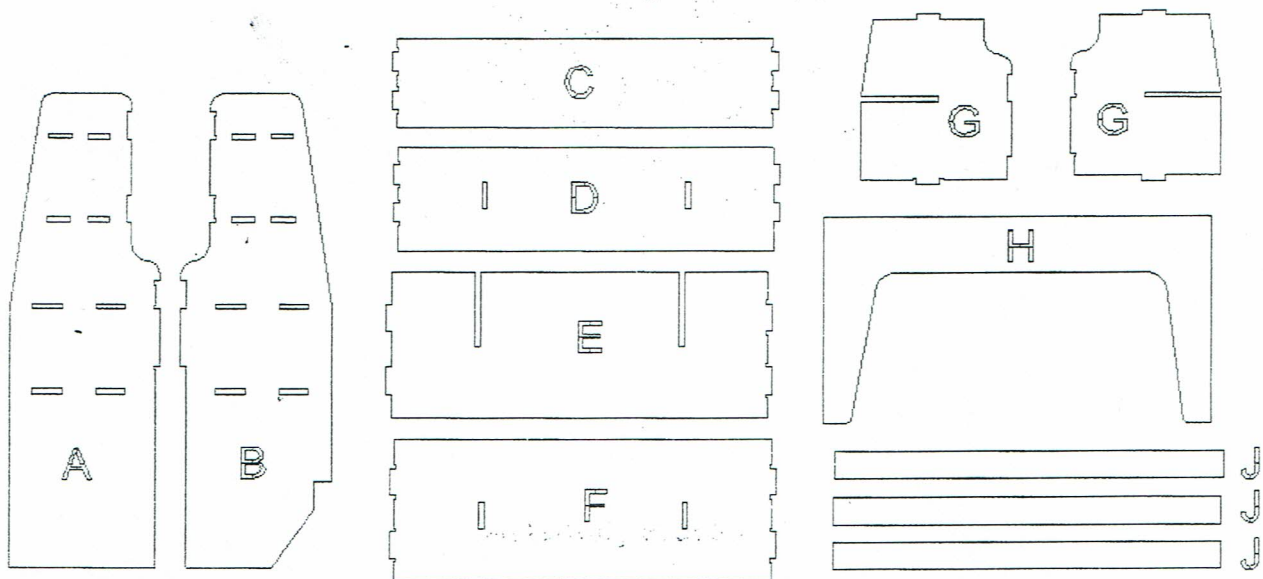

Note this unit is designed to work on either side of the van on top of the wheel arch. Looking at the unit from the front if fitting to the driver side of the van make sure panel B is on the left-hand side. If fitting to the nearside of the van make sure that Panel B is on the right hand side of the unit.

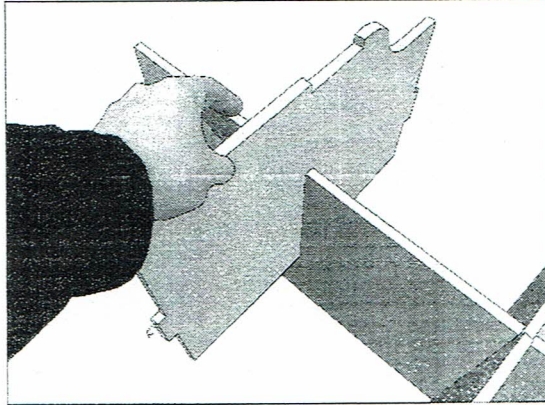

Take both the G panels and slide them into panel E, the panels will interlock into one another.

Locate panel F onto the bottom of the two G panels. The back edge of the panel should be flat against the floor. Now secure F with screws.

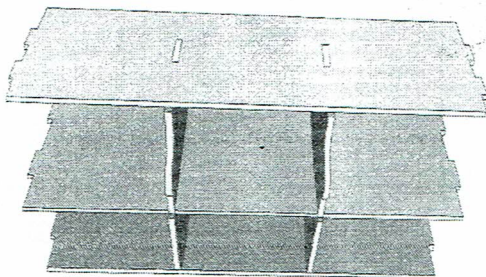
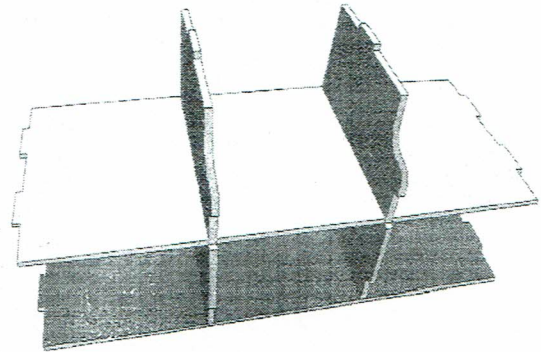

Place panel D on top of the two G panels. Once positioned secure with screws.

The assembly should look like the image at this stage.

At this stage the decision has to be made if the unit is to be fitted on the driver side or passenger side of the van.

Lift the assembly and locate it into the slots in the panel lay on the floor. Then carefully turn the unit over to allow fixing with screws through the panel.

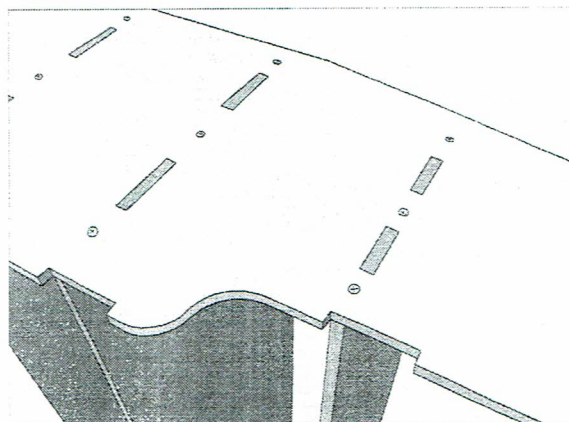
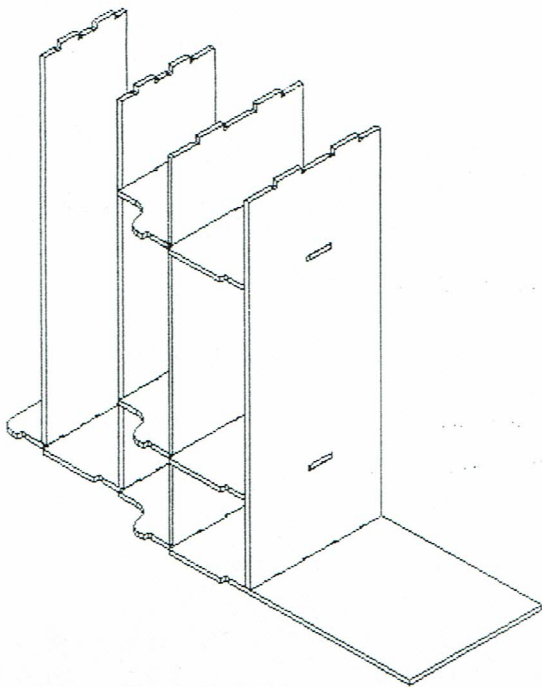

Take panel C and fit it into the remaining slots in the end panel. Lift on the remaining end panel (A or B), locate the shelves into the slots and fix with screws.

Top and bottom back panels are different, make sure that the drill marker dots line up with the shelves. If the bottom back panel is positioned correctly both backs should meet on the middle of the third shelf.

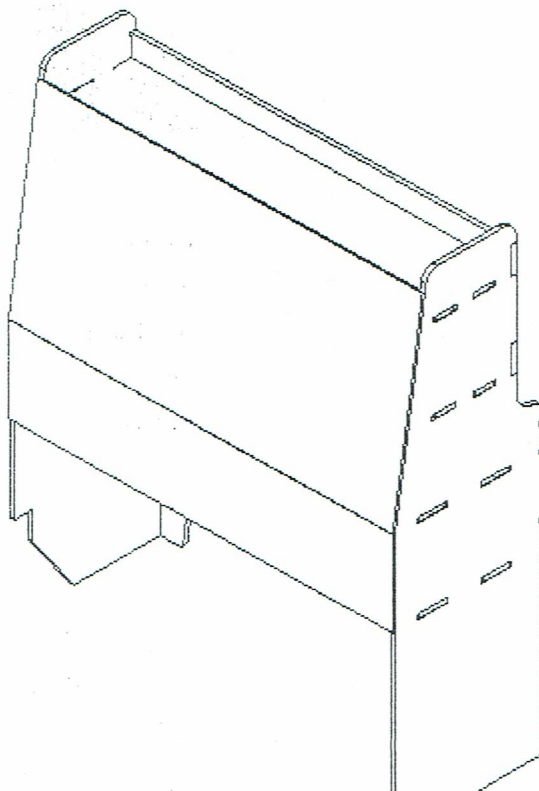

Fit the J strips fit into the recesses on the front, these are screwed to the shelves to form a retaining lip.

Panel H is positioned as per the image and fixed with screws.

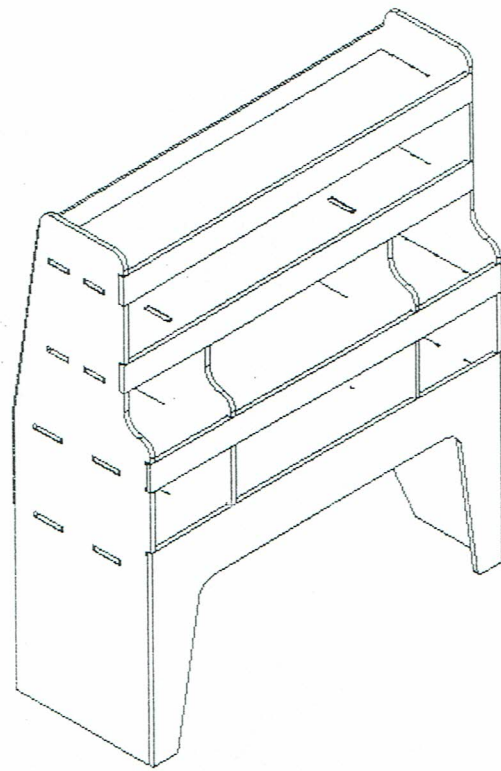

The assembled unit, should now be complete. Please ensure that when fitting in your van that it is securely fixed to the van floor and sides. Use angle brackets to secure to your van, these are not supplied by ourselves you need to source these yourself.