

360° PHOTO BOOTH

29931 / 29932 / 29933

INSTRUCTION MANUAL

www.monstershop.co.uk



SPECIFICATION

PRODUCT DESCRIPTION

So, you want to make your event special and unforgettable, whether you're planning a birthday party, a wedding bash, or a school leavers' ball the 360° Photo Booth is the perfect device to capture all those treasured memories.

The 360° Booth is compatible with many types of film and photo capture technology including tablet's, GoPro's, Digital Camera's or even your smartphone. Simple and quick set-up and with one-touch trigger system means a hassle-free experience for you. Supplied with a rechargeable 24V battery, you have the flexibility to use the booth without plugging into the mains. (Limited running time when only used with the battery.)

So, what are you waiting for? Time to get shooting!

Please refer to and read the Safe Working Practice to ensure prevention of injury or damage to the device before starting.

PRODUCT SPECIFICS

MODEL	MAX HEIGHT	WIDTH	DEPTH	WEIGHT
80cm	215cm	80cm	80cm	43kg
100cm	215cm	100cm	100cm	64kg
115cm	215cm	115cm	115cm	74kg

MATERIAL: Powder Coated Steel
POWER: 240v @ 50htz
BATTERY: 24V
PLATFORM WEIGHT CAPACITY: 400kg

BLUETOOTH SPECIFICATIONS:

COMMUNICATION: V4.0
TRANSMIT FREQUENCY: 2.4GHz - 2.4835GHz
COMMUNICATION DISTANCE: 10m (30ft)
BATTERY: CR2032 X1

SPECIFICATION

ITEM CONTENTS

PART	QTY	NAME
A	1x	Base Unit
B	1x	Metal Motion Arm with Adjustment Bracket
C	1x	Metal Motion Arm
D	1x	Selfie Telescopic Pole
E	1x	Smartphone Bracket
F	1x	Tablet Bracket
G	1x	LED Ring Light
H	1x	Smartphone Bracket (for use within LED Ring Light)
I	1x	GoPro Bracket
J	10x	Short Plum Screws
K	1x	Long Plum Screw
L	1x	Spherical Tripod Head
M	2x	Booth Remote Control
N	1x	Power Adaptor
O	1x	LED Ring Light Remote Control
P	1x	Money Gun with 100 Fake Notes
Q	1x	Bag of Photo Props
R	4x	Base Logo Stickers
S	1x	LED Light Strip
T	1x	LED Light Strip Remote Control
U	1x	Emergency Stop Pedal
V	2x	Equipment Carry Bags
W	1x	Flight Case
X	1x	2.5mm L-Shaped Allen Key
Y	1x	Battery Pack
Z	1x	Power Cord

SPECIFICATION

PRODUCT FEATURES

1. Base
2. Adjustable Angle (36° - 156°)
3. Adjustable Length (40cm - 155cm)
4. Multi-Function Bracket
5. LED Ring light
6. Smart Phone Bracket

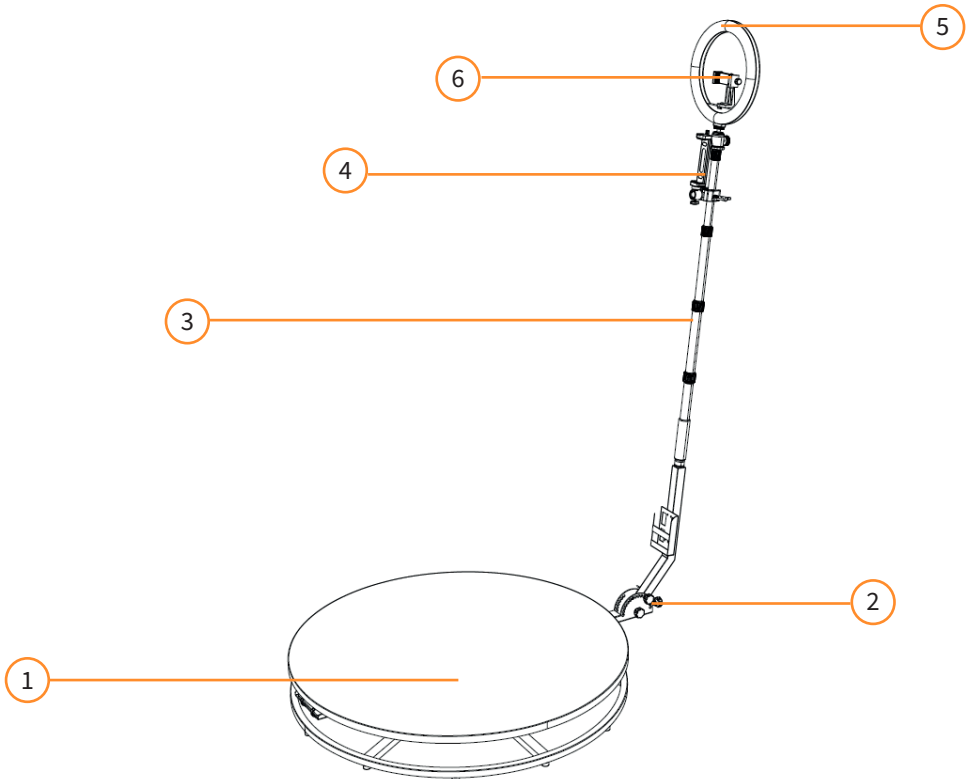

Monster Group UK Limited's liability will be limited to the commercial value of the product only.

SAFETY ADVICE

SAFE WORKING PRACTICE

Please read through the Safe Working Practice to ensure prevention of injury or damage to the device.

- Do not use this product for anything other than its intended purposes.
- Ensure you have read and fully understood the instruction manual and safety advice before using this product.
- Do not use around water or other liquids or allow the product to become wet.
- Inspect the product for signs of significant damage or wear before and after every use. If significant damage is spotted, arrange for repair.
- Do not attempt repairs yourself. Only a qualified technician should carry out repairs on this product.
- Do not alter or modify this product in any way.
- Ensure this product is switched off and unplugged when not in use.
- Do not leave this product unattended whilst it is in use.
- Use correct posture and lifting techniques when lifting, moving, or setting up equipment.
- We recommend that a trained and competent operator is present when the booth is in use.
- Ensure that the booth is placed on a flat and level surface.
- Do not exceed the Max load for the platform.
- Do not jump on the platform or allow users to jump on the platform.
- Ensure any cables are tied or taped down.
- Ensure any props are returned to a suitable container or area after use to reduce any tripping hazard.
- Ensure the emergency stop pedal is located close to the operator so it can be easily accessed in the event of an emergency. It also reduces any trip hazard.

USER GUIDE

ASSEMBLY INSTRUCTIONS

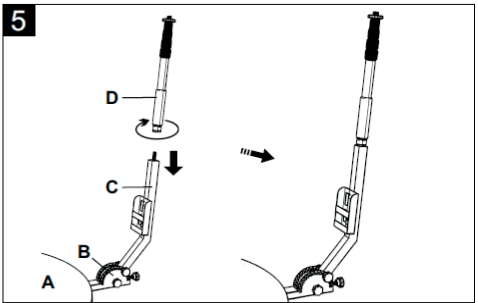
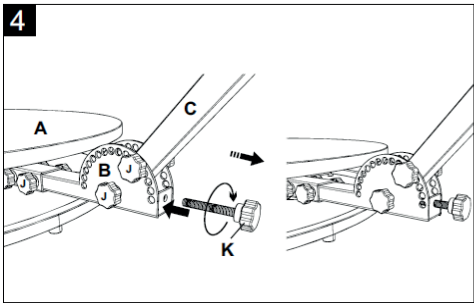
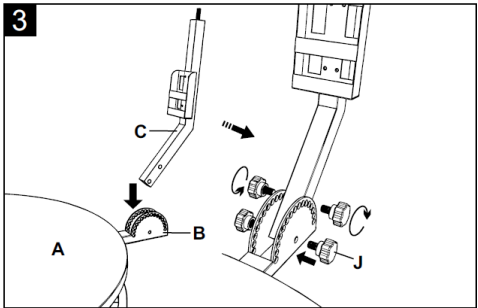
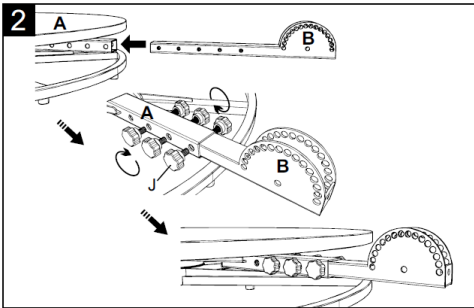
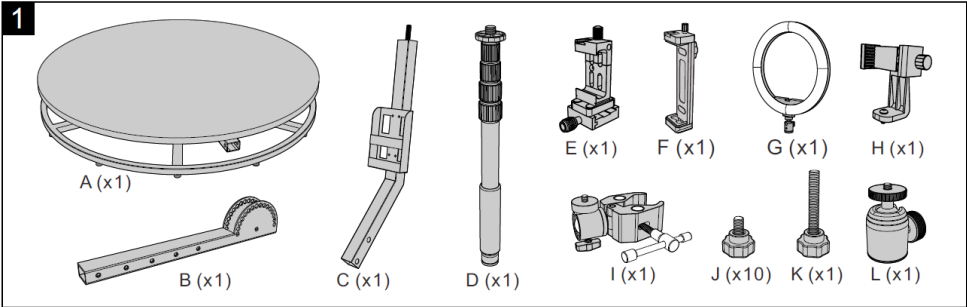

USER GUIDE

ASSEMBLY INSTRUCTIONS

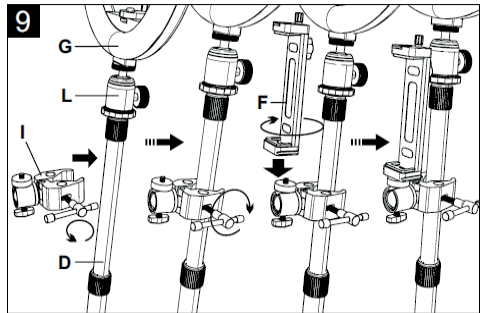
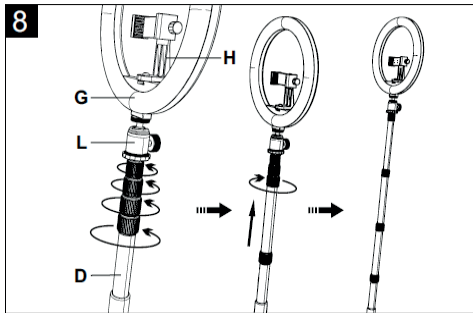
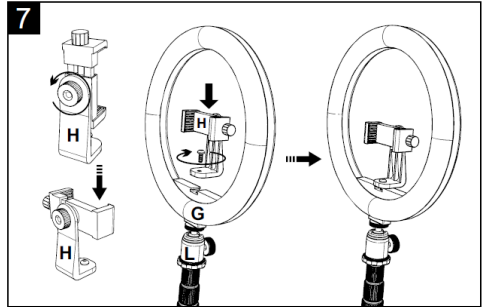
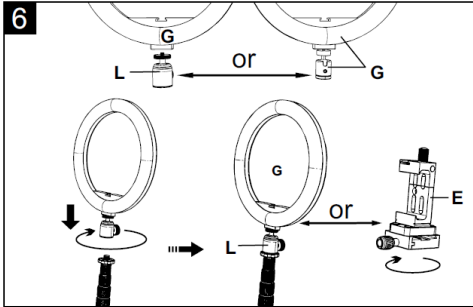

USER GUIDE

ASSEMBLY INSTRUCTIONS

1. Ensure you have all the parts on the Items List before you start assembly.
2. Attach the Motion Arm (B) with 3 short plum screws to the Base unit (A).
3. Attach the Motion Arm (C) using 2 short plum screws (J).
4. You can adjust the angle of the Motion Arm and secure using the long plum screw (K).
5. Attach the Selfie Telescopic Pole (D).
6. To the top of the Selfie Telescopic Pole, you can attach the Tripod Head (L), the LED Ring Light (G) or the Smartphone Bracket (E).
7. If using the LED Ring Light (G) you can also attach the smartphone bracket (H).
8. The Selfie Telescopic Pole (D) is adjustable by turning the adjustable collars.
9. The GoPro Bracket (I) can be clamped onto the Selfie Telescopic Pole (D) and the Tablet Bracket (F) can be attached to the GoPro Bracket (I)

INSTRUCTIONS FOR BLUETOOTH SHUTTER

PAIRING WITH A DEVICE

1. Turn on the Bluetooth shutter using the on/off switch. The shutter will enter pairing mode and the LED will start to flash quickly.
2. Activate the Bluetooth function on your phone and search for the shutter.
3. Select device 'AB Shutter3' from the list and pairing will be finished after a few seconds.

USING THE BLUETOOTH SHUTTER

You can use the inbuilt camera app on your smartphone or tablet to take photos or videos with the Bluetooth shutter.

Once you are ready press the shutter button on the remote shutter.

USER GUIDE

INSTRUCTIONS FOR USING THE 360° BOOTH

Once assembly is complete the 360° Photo Booth and the LED lights can be powered using either the mains power supply or the 24v battery.





Mains - Plug the Power Adaptor into the mains power supply. A Green light will indicate the power adaptor is on and the base will emit a short beep to indicate that it is on.

Battery - If only using the battery, then the battery charge will last approx. 5-6 hours.

If using the battery to power the LED lights as well as the booth, then the charge will last approx. 2-3 hours.





The battery is recharged using the mains power supply and is fully recharged in 2-3 hours.

INSTRUCTIONS FOR BOOTH REMOTE CONTROL

-  Start / Pause. Press once to start the motion arm, press again to stop.
-  Reversing: Press to reverse the direction of the motion arm.
-  Speed up: Increase the speed of the motion arm.
-  Slow Down: Decreases the speed of the motion arm.

USER GUIDE

INSTRUCTIONS FOR THE LED RING LAMP

BUTTON	FUNCTION
	Turns on LED Ring Light
	Turns off LED Ring Light
	This cycles through the three different modes: Static - Solid Colours Dynamic - Changes Colour Microphone - Lights react to ambient sounds or music
	Lets you select one of 16 static Colours
	Increase and Decrease the speed of the lighting effects





















INSTRUCTIONS FOR CAMERA APP

Once you have assembled the 360° Photo Booth we recommend that you download the accompanying App to allow you to fully utilise all the features of the LED Light Strip.

Search your App store for BanLanX and once downloaded onto your device you will be able to access features such as saving your favourite lighting preferences and using the three 'Music' modes.

USER GUIDE

INSTRUCTIONS FOR LED LIGHT STRIP

BUTTON	FUNCTION	BUTTON	FUNCTION
	Turns on light strip		Auto Favourites
	Turns off light strip		Increase Speed
 to 	Select colours		Decrease Speed
Rainbow	Rainbow Effect		Increase Brightness
Meteor	Meteor Effect		Decrease Brightness
Stars	Star Effect		Increase Length
Fire	Fire Effect		Decrease Length
	Cycle up through modes		Cycle up through music modes
	Cycle down through modes		Cycle down through music modes
	Cycle up through favourite modes		Auto Music Mode
	Cycle down through favourite modes		Change Colour
	Auto Modes		

TROUBLESHOOTING

RESOLUTION GUIDE

WHAT DO I DO IF THERE ARE MISSING PARTS FROM MY ORDER?

If there appears to be any part missing from your order, contact our friendly and helpful Customer Support Team within 7 days of receipt.

WHAT DO I DO IF THE MOTION ARM WON'T ROTATE?

Check that the Booth is on a flat and level surface with no objects blocking the path of the motion arm.

Ensure the power supply is connected correctly.

Check the remote control for a flat battery and replace if required (CR2032)

WHAT DO I DO IF THE MOTION ARM IS NOISY?

If there is a rattle from the motor reduction box when using the Booth then please contact Customer Services before using the Booth again.

If there is a noise from the drive belt connecting the motor to the base then check to ensure the motor unit, belt and base unit wheel are level with each other.

WHAT DO I DO IF THE MOTION ARM IS SHAKING?

Check the Plum screws and tighten if required. Also check the telescopic arm is fitted correctly and tighten if required. Ensure all other accessories are fitted correctly.

**FOR ALL OTHER ISSUES, PLEASE CONTACT OUR
CUSTOMER SUPPORT TEAM.**



SPÉCIFICATIONS

DESCRIPTION DU PRODUIT

DÉTAILS DU PRODUIT

LISTE DES PIÈCES

SPÉCIFICATIONS

CARACTÉRISTIQUES DU PRODUIT

La responsabilité de Monster Group UK Limited sera limitée à la valeur commerciale du produit.

CONSEILS DE SÉCURITÉ

 PRATIQUE DE TRAVAIL SÉCURITAIRE

MODE D'EMPLOI

INSTRUCTIONS DE MONTAGE

MODE D'EMPLOI

ENTRETIEN

DÉPANNAGE

GUIDE DE RÉOLUTION

QUE FAIRE S'IL MANQUE DES PIÈCES À MA COMMANDE?

S'il semble manquer des pièces à votre commande, contactez notre équipe du service client dans les 7 jours suivant la réception.

**POUR TOUT AUTRE PROBLÈME, VEUILLEZ
CONTACTER NOTRE ÉQUIPE DU SERVICE CLIENT.**



SPEZIFIKATIONEN

PRODUKTBESCHREIBUNG

PRODUKTSPEZIFIKA

TEILELISTE

SPEZIFIKATION

PRODUKTMERKMALE

Die Haftung von Monster Group UK Limited ist auf den Handelswert des Produkts beschränkt.

SICHERHEITSHINWEIS

 SICHERES ARBEITEN

BENUTZERLEITFADEN

MONTAGEANLEITUNGEN

BENUTZERLEITFADEN

WARTUNG

FEHLERBEHEBUNG

LÖSUNGSGUIDE

WAS MACHE ICH, WENN BEI MEINER BESTELLUNG TEILE FEHLEN?

Falls bei Ihrer Bestellung ein Teil zu fehlen scheint, wenden Sie sich bitte innerhalb von 7 Tagen nach Erhalt der Ware an unser freundliches und hilfsbereites Kundenservice-Team.

**FÜR ALLE ANDEREN FRAGEN WENDEN SIE SICH BITTE AN
UNSER KUNDENSERVICE-TEAM.**



ESPECIFICACIONES

DESCRIPCIÓN DEL PRODUCTO

ESPECIFICACIONES DEL PRODUCTO

LISTA DE PIEZAS

ESPECIFICACIONES

CARACTERÍSTICAS DEL PRODUCTO

La responsabilidad de Monster Group UK Limited estará limitada únicamente al valor comercial del producto.

CONSEJOS DE SEGURIDAD

PRÁCTICAS DE TRABAJO SEGURAS

GUÍA DEL USUARIO

INSTRUCCIONES DE ENSAMBLAJE

GUÍA DEL USUARIO

MANTENIMIENTO

SOLUCIÓN DE PROBLEMAS

GUÍA DE RESOLUCIÓN

¿QUÉ PUEDO HACER SI LE FALTAN PIEZAS A MI PEDIDO?

Si parece faltar alguna pieza en su pedido, por favor, comuníquese con nuestro amable y servicial Equipo de Atención al Cliente en los 7 días posteriores a la recepción de su pedido.

**PARA CUALQUIER OTRO PROBLEMA, POR FAVOR CONTACTE
CON NUESTRO EQUIPO DE ATENCIÓN AL CLIENTE**



SPECIFICHE

DESCRIZIONE DEL PRODOTTO

SPECIFICHE DEL PRODOTTO

LISTA COMPONENTI

SPECIFICHE

CARATTERISTICHE DEL PRODOTTO

La responsabilità di Monster Group UK Limited sarà limitata al solo valore commerciale del prodotto.

CONSIGLI PER LA SICUREZZA

 PRATICHE DI LAVORO SICURO

GUIDA UTENTE

ISTRUZIONI PER IL MONTAGGIO

GUÍA DEL USUARIO

MANTENIMIENTO

RISOLUZIONE DEI PROBLEMI

GUIDA ALLA RISOLUZIONE DEI PROBLEMI

COSA DEVO FARE SE NEL MIO ORDINE CI SONO DELLE PARTI MANCANTI?

Se sembra che all'interno del tuo ordine manchino delle parti, contatta il nostro gentile e disponibile team di assistenza clienti entro 7 giorni dalla ricezione del tuo ordine.

**PER QUALUNQUE ALTRO PROBLEMA, CONTATTA IL NOSTRO
TEAM DI ASSISTENZA CLIENTI.**



OMSCHRIJVING

PRODUCT OMSCHRIJVING

PRODUCTSPECIFICATIES

ONDERDELENLIJST

SPECIFICATIE

PRODUCT SPECIFICATIE

De aansprakelijkheid van Monster Group UK Limited is beperkt tot de commerciële waarde van het product.

VEILIGHEIDSADVIIES

 VEILIG GEBRUIK

HANDLEIDING

MONTAGE-INSTRUCTIES

HANDLEIDING

ONDERHOUD

PROBLEEM OPLOSSEN

OPLOSSINGEN

WAT MOET IK DOEN ALS ER ONDERDELEN VAN MIJN BESTELLING ONTBREKEN?

Neem wanneer een onderdeel van je bestelling ontbreekt binnen 7 dagen na ontvangst contact op met onze vriendelijke en behulpzame klantenservice.

**NEEM VOOR ALLE ANDERE KWESTIES CONTACT
MET ONZE KLANTENSERVICE OP.**



SPECIFIKATION

PRODUKTBESKRIVNING

PRODUKTSPECIFIKATIONER

MEDFÖLJANDE DELAR

SPECIFIKATION

PRODUKTFUNKTIONER

SÄKERHETSÅD

 SÄKER ARBETSÖVNING

ANVÄNDARGUIDE

MONTERINGS INSTRUKTIONER

BRUKSANVISNING

SKÖTSEL

FELSÖKNING

LÖSNINGSGUIDE

VAD GÖR JAG OM DET SAKNAS DELAR FRÅN MIN BESTÄLLNING?

Om det verkar som om någon del saknas i din beställning, kontakta vårt vänliga och hjälpsamma kundsupportteam inom 7 dagar efter mottagandet.

**FÖR ALLA ANDRA FRÅGOR, VÄNLIGEN KONTAKTA VÅRT
KUNDSUPPORTTEAM.**

Monster Group (UK) is one of the UK's fastest growing online retailers. We supply a diverse range of products which offer exceptional value for money. We strive to provide the best possible customer experience with free UK delivery across all our products and a Monster Guarantee for 100% satisfaction.

For information regarding this device or other products from our Monster divisions please contact Sales.

SALES

TEL: 01347 878 888

EMAIL: hello@monstershop.co.uk

For queries about this device, warranty, returns or reporting faults please contact Support.

SUPPORT

TEL: 01347 878 887

EMAIL: help@monstershop.co.uk

Pour plus d'informations concernant cet appareil ou d'autres produits de nos divisions de Monster veuillez utiliser les détails suivants ci-dessous.

DÉPARTEMENT COMMERCIAL

TEL: 01347 878 888

EMAIL: bonjour@monstershop.eu

Pour les interrogations concernant cet appareil, la garantie, les retours ou les défauts de déclaration veuillez utiliser les détails suivants ci-dessous.

DÉPARTEMENT DE SOUTIEN

TEL: 01347 878 887

EMAIL: help@monstershop.co.uk

Para información sobre este dispositivo u otros productos de nuestras divisiones de Monster por favor use los siguientes detalles.

DEPARTAMENTO DE VENTAS

TEL: 01347 878 888

EMAIL: hola@monstershop.eu

Para consultas sobre este dispositivo, la garantía, devoluciones o denuncias de fallos por favor use los siguientes detalles.

DEPARTAMENTO DE SOPORTE

TEL: 01347 878 887

EMAIL: help@monstershop.co.uk

Für Informationen bezüglich dieses Geräts oder anderer Produkte aus unserer Monster-Abteilung, benutzen sie die folgenden unten aufgeführten Angaben.

VERKAUFABTEILUNG

TEL: 01347 878 888

EMAIL: hallo@monstershop.eu

Für Fragen über dieses Gerät, die Garantie, Rückgaben oder bei Störungen, benutzen sie die folgenden unten aufgeführten Angaben.

SUPPORT-ABTEILUNG

TEL: 01347 878 887

EMAIL: help@monstershop.co.uk

Per informazioni riguardanti questo dispositivo o altri prodotti dalle categorie Monster utilizzare i dettagli sotto riportati.

DIPARTIMENTO VENDITE

TEL: 01347 878 888

EMAIL: ciao@monstershop.eu

Per domande riguardo dispositivo, garanzia, reso o per riferire di guasti, utilizzare i dettagli sotto riportati.

DIPARTIMENTO SUPPORTO

TEL: 01347 878 887

EMAIL: help@monstershop.co.uk

Monster House, Alan Farnaby Way,
Sheriff Hutton Industrial Estate,
Sheriff Hutton, York, YO60 6PG
www.monstershop.co.uk



 Try **Monster**. Buy **Monster**. Be **Monster**. 