



24247/24248/24250

Metal Filing Cabinet



MonsterShop

Try **Monster** - Buy **Monster** - Be **Monster**

Specification

Product Description

This Metal Filing Cabinet is ideal for all types of office storage. Its simple design allows it to correspond with all types of decor, making it an invaluable addition to any office! All shelves are adjustable so you can fit any type of document into your cabinet perfectly. The added locking mechanism ensures that all your files are kept safe and secure within!

The powder coated steel finish also makes this an easy to maintain and stylish cabinet that we know you'll love.

Item Contents

90cm Metal Filing Cabinet:

1 x Rear Panel	9 x Screws
2 x Side Panels	8 x Shelf Brackets
1 x Front Panel (with 2 x Doors attached)	2 x Metal Dowels
2 x Shelves	2 x Keys
1 x Roof Panel	
1 x Floor Panel	

140cm Metal Filing Cabinet:

1 x Rear Panel	11 x Screws
2 x Side Panels	12 x Shelf Brackets
1 x Front Panel (with 2 x Doors attached)	2 x Metal Dowels
3 x Shelves	2 x Keys
1 x Roof Panel	
1 x Floor Panel	

Specification

Item Contents

180cm Metal Filing Cabinet:

1 x Rear Panel	13 x Screws
2 x Side Panels	16 x Shelf Brackets
1 x Front Panel (with 2 x Doors attached)	2 x Metal Dowels
4 x Shelves	2 x Keys
1 x Roof Panel	
1 x Floor Panel	

For your reference, please consult the pictures below to familiarise yourself with each smaller item.

Screw:



Shelf Bracket:



Metal Dowel:



(NOTE: The Metal Dowels are already fitted into the doors so there is no assembly required here. If you decide to remove the doors for storage, ensure you keep these two pieces for future use).

Specification

Product Specifics

90cm Metal Filing Cabinet:

Dimensions (H x W x D): 90cm x 90cm x 40cm

Weight: 22 KG

Material: 0.5mm Steel

140cm Metal Filing Cabinet:

Dimensions (H x W x D): 140cm x 90cm x 40cm

Weight: 28.5 KG

Material: 0.5mm Steel

180cm Metal Filing Cabinet:

Dimensions (H x W x D): 180cm x 90cm x 40cm

Weight: 36 KG

Material: 0.5mm Steel

Monster Guarantee

If you wish to return a product in perfect working order, we provide a 30 day returns policy as long as the item is unopened and in a resalable condition.

A 12 month warranty applies to all of our electrical products; we will cover the cost of labour and parts. Our policy is to try and repair the item before arranging an exchange or refund.











If for any reason a part is missing please get in touch with us within 7 days on receipt of your order. You can contact our friendly and helpful Customer Support Team via email or call. For full terms and conditions contact our Support Department via the details on the Contact Us page.

Monster Group UK's liability will be limited to the commercial value of the product only.

User Guide

Assembly Instructions

NOTE: This assembly requires two persons. We strongly recommend you **DO NOT** attempt the assembly by yourself.

Part	Part Name	Illustration
A	Left Side Panel	
B	Right Side Panel	
C	Rear Panel	
D	Front Panel (with doors attached)	
E	Roof Panel	
F	Floor Panel	
G	Shelf	
H	Screw	
I	Shelf Bracket	
J	Keys	

User Guide

Assembly Instructions

NOTE: The pictures in this manual show assembly for the 180cm Metal Filing Cabinet. Both the 90cm and 140cm Metal Filing Cabinets are assembled in a very similar format. Read these Assembly Instructions carefully to ensure you are using the correct number of screws.

1) On the Front Panel (D), ensure the doors are locked so that they cannot swing open during assembly. Attach the Left Side Panel (A) to the edge of the Front Panel (D). Notice that the grooves on each panel lock into place without screws. Ensure the joint is flush like so.



2) Attach the Right Side Panel (B) to the Front Panel (D). It should now look like the picture below.

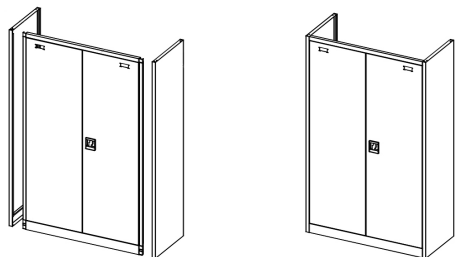

User Guide

Assembly Instructions

3) Now attach the **Rear Panel (C)** to the **Left Side Panel (A)** and the **Right Side Panel (B)** by connecting the grooves of each panel. Again, ensure each joint is flush.

4) Open the doors with the **Keys (J)**. Use **6 x Screws (H)** to fix the **Rear Panel (C)** to the frame. If you purchased the **140cm Filing Cabinet**, use **4 x Screws (H)** here. If you purchased the **90cm Filing Cabinet**, use **2 x Screws (H)** here.

ADVICE: We recommend keeping the frame as aligned as possible at this point. Whilst one person holds the joints tight, another can screw together the frame.

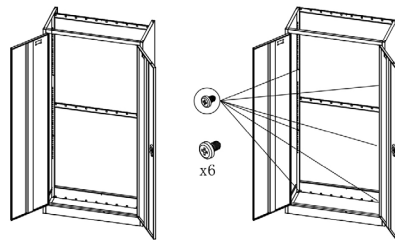

5) The frame should now look like the picture below (shown without doors). Notice that the apex of the cross on the **Rear Panel (C)** is towards the lower end of the frame.



User Guide

Assembly Instructions

6) Now attach the **Roof Panel (E)**. Place the **Roof Panel (E)** inside the frame and push it towards the top of the frame. Standing from inside the frame, align the holes and, again whilst another person holds in place, use **6 x Screws (H)** to fit. Using **6 x Screws (H)** applies to all models.

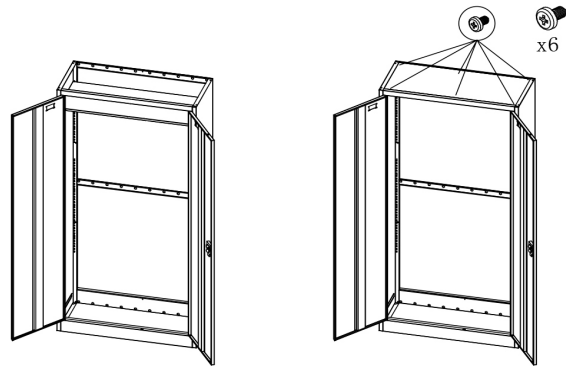

7) Notice that at the base of the frame, there are two catches at either side, where the **Floor Panel (F)** will sit. See the picture below. Lay the frame on its back and place the **Floor Panel (F)** into the frame. Fit into place. Underneath the base is the final screw hole. Align and use **1 x Screw (H)**. Ensure the base is even before screwing.



User Guide

Assembly Instructions

8) To insert the **Shelves (G)**, first stand the cabinet upright. Slot the **Shelf Brackets (I)** into the allotted holes within the cabinet. See the picture below. Note that each shelf requires 4 x **Shelf Brackets (I)**. Ensure the **Shelf Brackets (I)** align with one another.



9) Once fitted, place your **Shelves (G)** into the cabinet and ensure they rest firmly and comfortably on the **Shelf Brackets (I)** before placing items on them.

10) Your Metal Filing Cabinet is now ready for use.

Troubleshooting

Resolution Guide

Please read through the guide below if you have any issues or faults with your device. The information covers and resolves the majority of frequently asked questions.

Q: There are parts missing from my order.

A: If there appears to be any part missing from your package contact our Customer Support team via the details on the Contact Us page within 7 days of receipt.

Q: My shelves are warping.

A: The shelves may be loaded with a higher weight than their maximum capacity. Remove some of the items to prevent further damage.

Q: How do I clean and/or maintain my Filing Cabinet?

A: A damp cloth can be used to clean the shelves. Do not use oil or harsh abrasives when cleaning, as this could damage the metal.

For all other issues please contact our Customer Support department via the details on the Contact page.

Safety Advice



Safe Working Practice

Please read through the safe working practice to ensure prevention of injury or damage to the device.

This item is heavy. Do not attempt to lift by yourself.

To avoid injury, ensure the cabinet is lifted/moved by 2 people.

Ensure the cabinet is placed on a flat and stable surface.

If the cabinet is raised off the floor, ensure that it is secured to a wall to prevent falling.

Contact Us

Sales Department

For information regarding this device or other products from our Monster divisions please use the following details below.

Tel: 01347 878888

Email: hello@monstershop.co.uk

Support Department

For queries about this device, warranty, returns or reporting faults please use the following details below.

Tel: 01347 878887

Email: help@monstershop.co.uk

Website

To view our product range and fantastic offers in the Monster Chef division please visit our website

www.monstershop.co.uk

Address

To visit our office Monster House and view our products, send postal correspondence or return items our address is provided below.

Monster House, Alan Farnaby Way, Sheriff Hutton
Industrial Estate, Sheriff Hutton, York YO60 6PG



Monster Group (UK) is one of the UK's fastest growing online retailers. We supply a diverse range of products which offer exceptional value for money. We strive to provide the best possible customer experience with free UK delivery across all our products and a Monster Guarantee for 100% satisfaction.

Our dedicated customer service team will be more than happy to help with any questions you may have.

Home & Garden
Storage Shelving
Sign & Digital
Retail & Hospitality
Commercial Equipment

Check out all our Monster brands at www.monstershop.co.uk
