

MODEL	SC-208F
CLIMATE CLASS	N-ST
ELECTRIC PROTECT CLASS	I
CAPACITY	175L
RATED VOLTAGE	220V-240V~
RATED FREQUENCY	50Hz
RATED CURRENT	1.0A
POWER INPUT	160W
ENERGY CONSUMPTION	1.12kW·h/24h
REFRIGERANT	R600a
CHARGING AMOUNT	50g
FOAM BLOWING AGENT	Cyclopentane
LIGHT	6W
NET WEIGHT	51kg

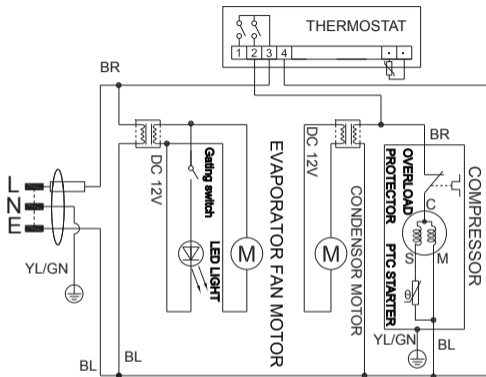

**UK  
CA**



**CE**



**Burns could result,  
do not touch the compressor.**