



# Workbench with Drawer & Light

210762 / 210794 / 210795

INSTRUCTION MANUAL

[www.monstershop.co.uk](http://www.monstershop.co.uk)



# SPECIFICATION

## PRODUCT DESCRIPTION

Our Workbench with Drawer & Light is the perfect solution to your storage needs. Hang all your must-have tools on the pegboard which has 40 hooks included, so that they are never out of reach.

Featuring a LED lamp to keep your sturdy work area well lit with a large bottom shelf, handy drawer and upper shelf, this workbench's ample storage will keep your workspace spick and span!

## PRODUCT SPECIFICS

### WORKBENCH

**MATERIAL:** Powder Coated Steel & MDF  
**DIMENSIONS:** 150cm (L) x 120cm (W) x 60cm (D)

### WEIGHT CAPACITY

**TOP SHELF:** 30KG  
**WORK AREA:** 200KG  
**BOTTOM SHELF:** 100KG  
**DRAWER:** 40KG

### LED LIGHT

**INPUT POWER:** 9-10W  
**DIMENSIONS:** 57.2cm (L) x 28cm (W) x 38cm (D)  
**FREQUENCY:** 50/60Hz

# SPECIFICATION

## PRODUCT FEATURES

- A. Top Shelf
- B. LED Light
- C. Work Area
- D. Drawer
- E. Peg Board
- F. Bottom Shelf



Monster Group UK Limited's liability will be limited to the commercial value of the product only.

# SPECIFICATION

## PARTS LIST

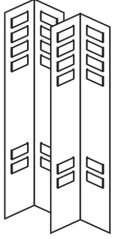

**A** Front Legs - x2



**B** Back Left Leg - x1



**C** Back Right Leg - x1

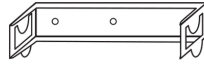

**D** Left Drawer Support - x1

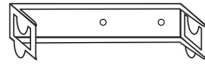

**E** Right Drawer Support - x1

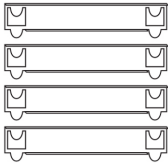

**F** Short Worktop Supports - x4

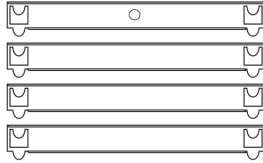

**G** Long Worktop Supports - x4



**H** Left Vertical Support - x1



**I** Right Vertical Support - x1



**J1** Back Support



**K** Left Top Shelf Support - x1



**L** Right Top Shelf Support - x1



**J2** Front Support



**M** Drawer Front - x1

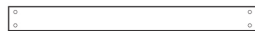

**N** Drawer Back - x1

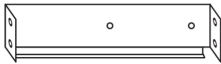

**O** Drawer Sides (Short) - x2



**P** Drawer Base - x1

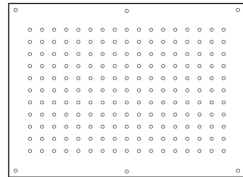

**Q** Peg Board - x1

Monster Group UK Limited's liability will be limited to the commercial value of the product only.

# SPECIFICATION

## PARTS LIST



**R** Bottom Shelf - x1



**S** Worktop - x1

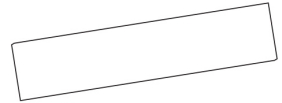

**T** Top Shelf - x1

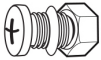

**V** Short Fixings - x30

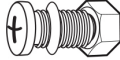

**W** Long Fixings - x6



**X** Nuts/Bolts (Small) - x18

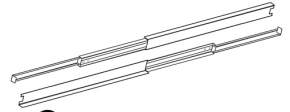

**U** Drawer Runners - x2



**Y** Pegboard Supports - x1

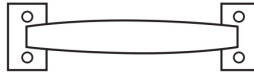

**S1** Drawer Handles - x2

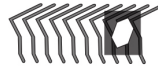

**S2** Pegs - x40



**S3** Cap Feet - x4

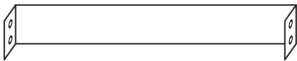

**S4** Drawer Support - x1



**S5** Support Bars - x2

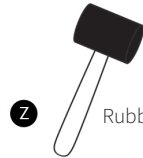

**Z** Rubber Mallet - x1

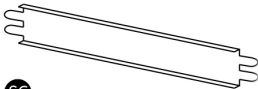

**S6** Support Bars - x4

# SAFETY ADVICE

## SAFE WORKING PRACTICE

Please read through the Safe Working Practice to ensure prevention of injury or damage to the device.

- Do not use this product for anything other than its intended use.
- Always keep the weight evenly distributed to avoid damage to the workbench and to prevent the workbench from falling over.
- Do not alter or modify this product in any way.
- Keep your construction area clear of clutter.
- Use this product on a flat surface.
- Ensure children, pets or animals are not in the vicinity when constructing this workbench.
- Do not exceed the load bearing capacity shown in the product specifics on page 2.
- Regularly inspect the product for damage and sign of wear. Tighten any components that appear to be loose.
- Ensure the moulded feet are attached correctly to prevent any potential injury.
- We recommend two people to assemble the product.
- The LED light is only suitable for a connection to a 240V-50Hz supply.
- The LED light is for indoor use only.
- Under no circumstances should the LED light be covered with any material.
- Do not plug the LED light cable into the mains until it has been connected to the LED Light.
- Do not install the LED light where it will be close to a water source. It is not suitable for a bathroom location.
- If the mains cable becomes damaged in any way, do not attempt to use it. Contact our Customer Support Team about a replacement.
- Allow the LED Light to cool for 10 minutes before removing from the brackets or attempting to clean.

# USER GUIDE

## ASSEMBLY INSTRUCTIONS

In order to allow room for the tabs to fit securely, it is recommended that you gently prise the tabs open using a suitable flat head screwdriver (not supplied). Once the tabs have been inserted, gently tap shut using a suitable rubber mallet to secure.

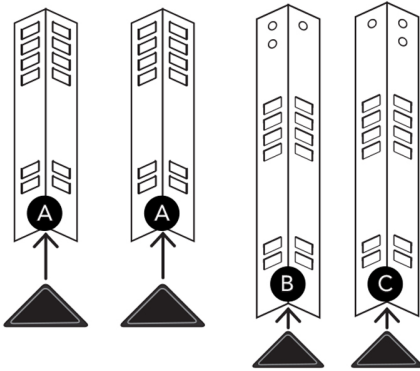

### STEP 1:

Clip the 4 Cap Feet (S3) onto the ends of the Legs (A, B, C) as illustrated.

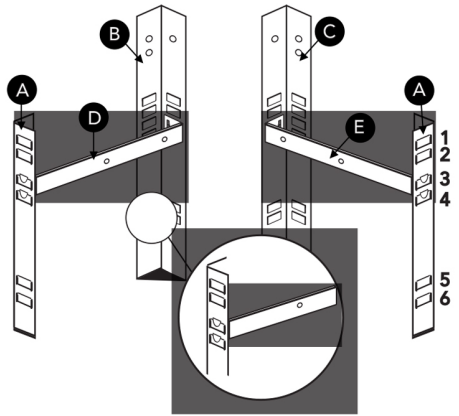

### STEP 2:

Fit the Drawer Supports (D, E) between the Front and Back Legs (A, B, C) and secure as illustrated.

The Drawer Supports should be fitted between the 3rd and 4th slots and face outwards.

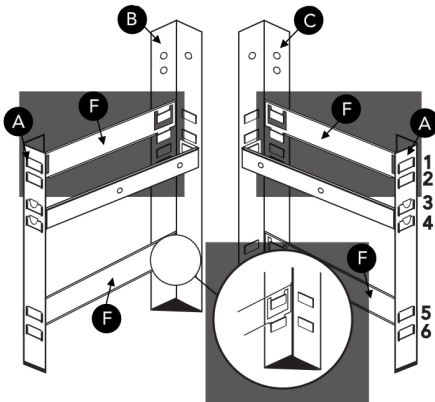

### STEP 3:

Fit the 4 Worktop Supports (F) to the Front and Back Legs (A, B, C) as illustrated.

The Short Worktop Supports should be positioned between the 1st/2nd and 5th/6th slots.

# USER GUIDE

## ASSEMBLY INSTRUCTIONS

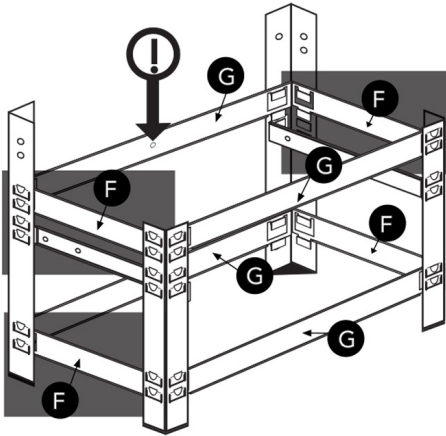

### STEP 4:

Fit the 4 Long Worktop Supports (G) to the Front and Back Legs (A, B, C) at the 1st/2nd and 5th/6th slots.

The Long Worktop Support with the central hole should be positioned between the 1st/2nd slots on the Back Legs (B, C).

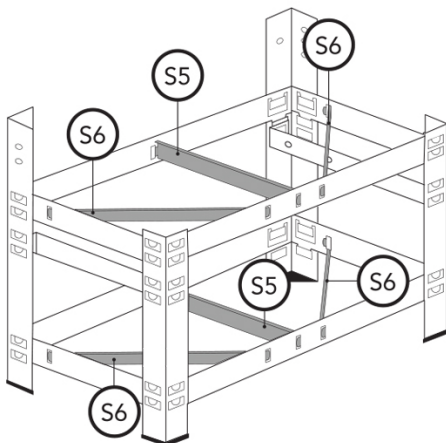

### STEP 4.1:

Fit the supports (S5 & S6) to the frame.

### STEP 5:

Bend the tabs on each end of the Support Bars (S5) to a 90° angle. Locate the slots at the top and bottom and slot into place between the Front & Rear Side Beams (G).

Bend the tabs back on themselves (as shown below) to attach.

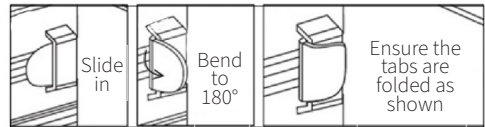

Fit the Left and Right Upper Vertical Supports (H, I) into the sides of the Back Legs (B, C).

Secure using 4 Short Fixings (V).

Tighten with a suitable spanner to secure. Secure the Support Bars (S5) into place using (W).

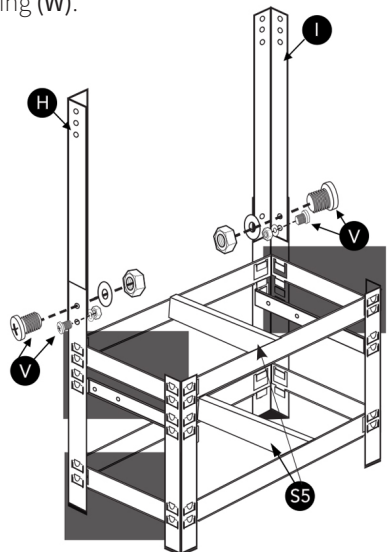



# USER GUIDE

## ASSEMBLY INSTRUCTIONS

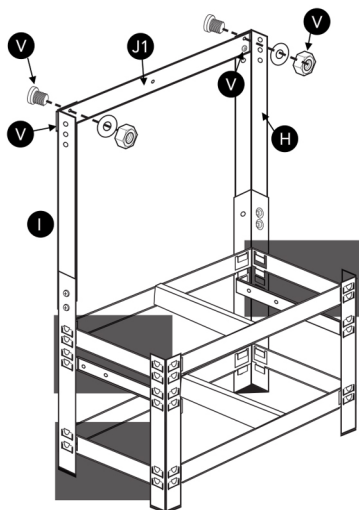

### STEP 6:

Fix the Back Support (**J1**) to the top 2 holes of the Vertical Supports (**H, I**). Secure using 4 Short Fixings (**V**). Tighten to secure.

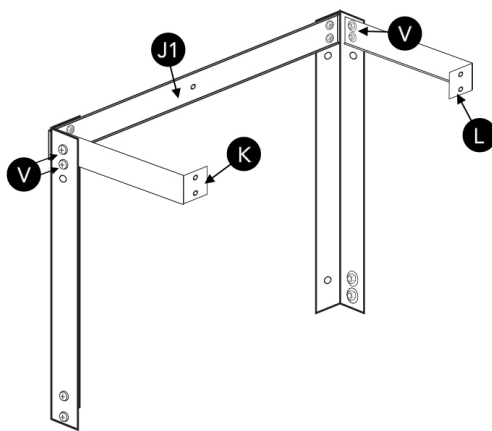

### STEP 7:

Fix the longest edge of the Short Top Shelf Supports (**K, L**) to the top 2 holes of the Vertical Supports (**H, I**) using 4 Short Fixings (**V**) as illustrated. Tighten to secure.

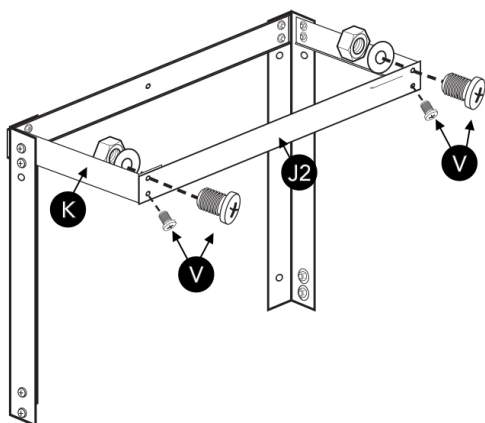

### STEP 8:

Fix the Front Support (**J2**) to the front of the Short Top Shelf Supports (**K, L**) using 4 Short Fixings (**V**) as illustrated. Tighten to secure.

# USER GUIDE

## ASSEMBLY INSTRUCTIONS

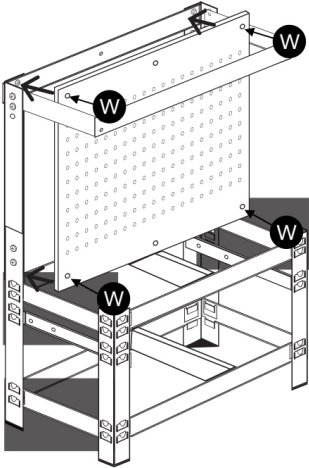

**STEP 9:**  
Fix Peg Board (Q) with 4 Long Fixings (W).  
Tighten to secure.

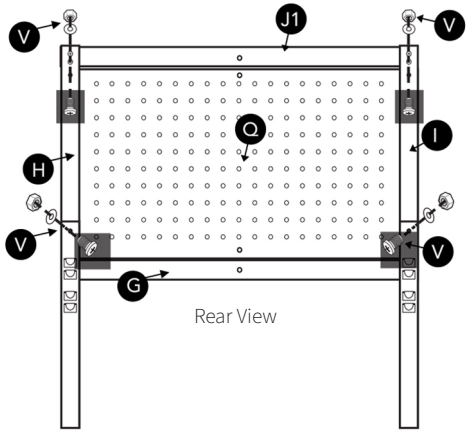

**STEP 10:**  
From the rear, insert 4 Short Fixings (V) into the vacant holes in the Vertical Supports (H, I). Tighten to secure.

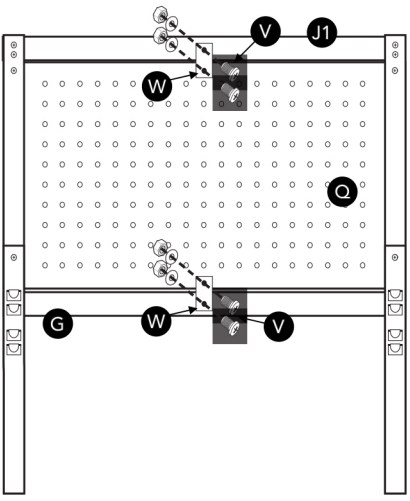

**STEP 11:**  
Using 2 Short Fixings (V), attach the Pegboard Supports (Y) to the rear of the assembly through the vacant holes on the Long Supports (G, J1).

Insert 2 Long Fixings (W) into the vacant holes on the Pegboard Supports (Y) and into the Pegboard (Q). Tighten all to secure.

# USER GUIDE

## ASSEMBLY INSTRUCTIONS

### STEP 12:

Fix the 2 Drawer Handles (**S1**) to the Drawer Front (**M**) by inserting 8 Small Nuts/Bolts (**X**) from the outside in towards the ledge. Tighten to secure.

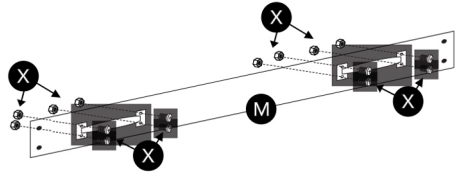

### STEP 13:

Fix the Short Drawer Sides (**O**) to the Drawer Front (**M**) using 4 Short Fixings (**V**). Tighten to secure.

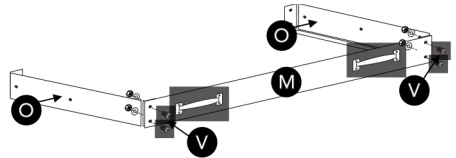

### STEP 14:

Lower the Drawer Base (**P**) into the Drawer Assembly to rest on the inner ledges. Fix the Long Drawer Back (**N**) to the assembly using 4 Short Fixings (**V**).

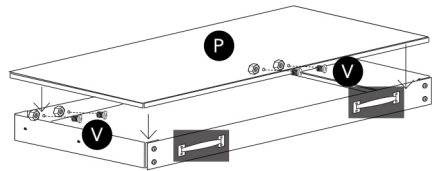

### STEP 15:

Fix the 2 Drawer Runners (**U**) to the Short Drawer Sides (**O**) using 4 Small Nuts/Bolts (**X**) through the available holes as illustrated. Tighten to secure.

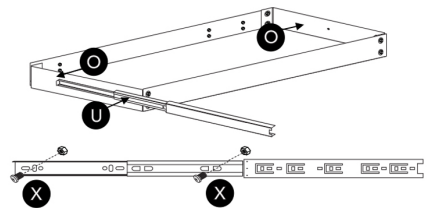

### STEP 16:

Holding the drawer within the Workbench assembly, extend and align the Drawer Runners (**U**) with the fixing holes in the Drawer Supports (**D, E**). Insert 4 Small Fixings (**X**) through the Runners and into the Supports. Tighten to secure.

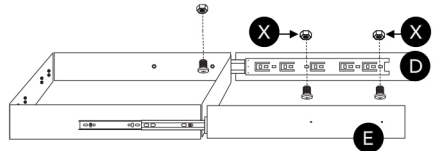

Insert the Drawer Support (**S4**) into the centre of the drawer and secure in place using (**W**).

# USER GUIDE

## ASSEMBLY INSTRUCTIONS

### **STEP 17:**

Fit the Worktop (**S**) and Bottom Shelf (**R**) by gently lowering them into the appropriate levels on the Workbench as illustrated.

**ADDITIONAL:** Insert Pegs (**S2**) into the Pegboard (**Q**) to hang tools for convenience.

### **STEP 18:**

Fit the Top Shelf (**T**) by placing it on top of the frame and securing in place with 2 Small Nuts /Bolts (**X**).

### **STEP 19:**

Now fit the LED Light Brackets (**S7**) to the underside of the Top Shelf (**T**) using the 2 X-Small Nuts/Bolts (**X1**).

# USER GUIDE

## ASSEMBLY INSTRUCTIONS

**STEP 20:**

Next insert either the UK (S9) or EU (S10) into the LED Light (S8).

**STEP 21:**

Push the LED Light (S8) into the brackets (S7) already fitted under the top shelf until they click into place.

**STEP 22:**

Feed the excess cable through the closest hole on the pegboard so it is out of the way of your workspace.

# USER GUIDE

## MAINTENANCE

- Treat the MDF boards with varnish or mould prevention products if using in a humid environment.
- Allow the LED Light to cool for 10 minutes before removing from the brackets or attempting to clean. Clean the LED Light with a dry cloth only.

# TROUBLESHOOTING

## RESOLUTION GUIDE

### WHAT DO I DO IF THERE ARE MISSING PARTS FROM MY ORDER?

If there appears to be any part missing from your order, contact our friendly and helpful Customer Support Team within 7 days of receipt.

**FOR ALL OTHER ISSUES, PLEASE CONTACT OUR  
CUSTOMER SUPPORT TEAM.**





# SPÉCIFICATIONS

DESCRIPTION DU PRODUIT

DÉTAILS DU PRODUIT

LISTE DES PIÈCES



# SPÉCIFICATIONS

## CARACTÉRISTIQUES DU PRODUIT

La responsabilité de Monster Group UK Limited sera limitée à la valeur commerciale du produit.

# CONSEILS DE SÉCURITÉ

 PRATIQUE DE TRAVAIL SÉCURITAIRE

# MODE D'EMPLOI

## INSTRUCTIONS DE MONTAGE

# MODE D'EMPLOI

## ENTRETIEN

# DÉPANNAGE

## GUIDE DE RÉOLUTION

### QUE FAIRE S'IL MANQUE DES PIÈCES À MA COMMANDE?

S'il semble manquer des pièces à votre commande, contactez notre équipe du service client dans les 7 jours suivant la réception.

**POUR TOUT AUTRE PROBLÈME, VEUILLEZ  
CONTACTER NOTRE ÉQUIPE DU SERVICE CLIENT.**



# SPEZIFIKATIONEN

PRODUKTBESCHREIBUNG

PRODUKTSPEZIFIKA

TEILELISTE

# SPEZIFIKATION

## PRODUKTMERKMALE

Die Haftung von Monster Group UK Limited ist auf den Handelswert des Produkts beschränkt.

# SICHERHEITSHINWEIS

 SICHERES ARBEITEN



# BENUTZERLEITFADEN

## MONTAGEANLEITUNGEN

# BENUTZERLEITFADEN

WARTUNG

# FEHLERBEHEBUNG

## LÖSUNGSGUIDE

### WAS MACHE ICH, WENN BEI MEINER BESTELLUNG TEILE FEHLEN?

Falls bei Ihrer Bestellung ein Teil zu fehlen scheint, wenden Sie sich bitte innerhalb von 7 Tagen nach Erhalt der Ware an unser freundliches und hilfsbereites Kundenservice-Team.

**FÜR ALLE ANDEREN FRAGEN WENDEN SIE SICH BITTE AN  
UNSER KUNDENSERVICE-TEAM.**



# ESPECIFICACIONES

DESCRIPCIÓN DEL PRODUCTO

ESPECIFICACIONES DEL PRODUCTO

LISTA DE PIEZAS

# ESPECIFICACIONES

## CARACTERÍSTICAS DEL PRODUCTO

La responsabilidad de Monster Group UK Limited estará limitada únicamente al valor comercial del producto.

# CONSEJOS DE SEGURIDAD

## PRÁCTICAS DE TRABAJO SEGURAS

# GUÍA DEL USUARIO

## INSTRUCCIONES DE ENSAMBLAJE

# GUÍA DEL USUARIO

## MANTENIMIENTO



# SOLUCIÓN DE PROBLEMAS

## GUÍA DE RESOLUCIÓN

### ¿QUÉ PUEDO HACER SI LE FALTAN PIEZAS A MI PEDIDO?

Si parece faltar alguna pieza en su pedido, por favor, comuníquese con nuestro amable y servicial Equipo de Atención al Cliente en los 7 días posteriores a la recepción de su pedido.

**PARA CUALQUIER OTRO PROBLEMA, POR FAVOR CONTACTE  
CON NUESTRO EQUIPO DE ATENCIÓN AL CLIENTE**



# SPECIFICHE

DESCRIZIONE DEL PRODOTTO

SPECIFICHE DEL PRODOTTO

LISTA COMPONENTI

# SPECIFICHE

## CARATTERISTICHE DEL PRODOTTO

La responsabilità di Monster Group UK Limited sarà limitata al solo valore commerciale del prodotto.

# CONSIGLI PER LA SICUREZZA

 PRATICHE DI LAVORO SICURO

# GUIDA UTENTE

## ISTRUZIONI PER IL MONTAGGIO

# GUÍA DEL USUARIO

## MANTENIMIENTO

# RISOLUZIONE DEI PROBLEMI

## GUIDA ALLA RISOLUZIONE DEI PROBLEMI

### COSA DEVO FARE SE NEL MIO ORDINE CI SONO DELLE PARTI MANCANTI?

Se sembra che all'interno del tuo ordine manchino delle parti, contatta il nostro gentile e disponibile team di assistenza clienti entro 7 giorni dalla ricezione del tuo ordine.

**PER QUALUNQUE ALTRO PROBLEMA, CONTATTA IL NOSTRO  
TEAM DI ASSISTENZA CLIENTI.**



# OMSCHRIJVING

PRODUCT OMSCHRIJVING

PRODUCTSPECIFICATIES

ONDERDELENLIJST



# SPECIFICATIE

## PRODUCT SPECIFICATIE

De aansprakelijkheid van Monster Group UK Limited is beperkt tot de commerciële waarde van het product.

# VEILIGHEIDSADVIIES

 VEILIG GEBRUIK

# HANDLEIDING

## MONTAGE-INSTRUCTIES

# HANDLEIDING

## ONDERHOUD

# PROBLEEM OPLOSSEN

## OPLOSSINGEN

### WAT MOET IK DOEN ALS ER ONDERDELEN VAN MIJN BESTELLING ONTBREKEN?

Neem wanneer een onderdeel van je bestelling ontbreekt binnen 7 dagen na ontvangst contact op met onze vriendelijke en behulpzame klantenservice.

**NEEM VOOR ALLE ANDERE KWESTIES CONTACT  
MET ONZE KLANTENSERVICE OP.**



# SPECIFIKATION

## PRODUKTBESKRIVNING

## PRODUKTSPECIFIKATIONER

## MEDFÖLJANDE DELAR

# SPECIFIKATION

## PRODUKTFUNKTIONER

# SÄKERHETSÅD

 SÄKER ARBETSÖVNING



# ANVÄNDARGUIDE

## MONTERINGS INSTRUKTIONER

# BRUKSANVISNING

## SKÖTSEL

# FELSÖKNING

## LÖSNINGSGUIDE

### VAD GÖR JAG OM DET SAKNAS DELAR FRÅN MIN BESTÄLLNING?

Om det verkar som om någon del saknas i din beställning, kontakta vårt vänliga och hjälpsamma kundsupportteam inom 7 dagar efter mottagandet.

**FÖR ALLA ANDRA FRÅGOR, VÄNLIGEN KONTAKTA VÅRT  
KUNDSUPPORTTEAM.**

Monster Group (UK) is one of the UK's fastest growing online retailers. We supply a diverse range of products which offer exceptional value for money. We strive to provide the best possible customer experience with free UK delivery across all our products and a Monster Guarantee for 100% satisfaction.

For information regarding this device or other products from our Monster divisions please contact Sales.

#### SALES

TEL: 01347 878 888

EMAIL: hello@monstershop.co.uk

For queries about this device, warranty, returns or reporting faults please contact Support.

#### SUPPORT

TEL: 01347 878 887

EMAIL: help@monstershop.co.uk

Pour plus d'informations concernant cet appareil ou d'autres produits de nos divisions de Monster veuillez utiliser les détails suivants ci-dessous.

#### DÉPARTEMENT COMMERCIAL

TEL: 01347 878 888

EMAIL: bonjour@monstershop.eu

Pour les interrogations concernant cet appareil, la garantie, les retours ou les défauts de déclaration veuillez utiliser les détails suivants ci-dessous.

#### DÉPARTEMENT DE SOUTIEN

TEL: 01347 878 887

EMAIL: help@monstershop.co.uk

Para información sobre este dispositivo u otros productos de nuestras divisiones de Monster por favor use los siguientes detalles.

#### DEPARTAMENTO DE VENTAS

TEL: 01347 878 888

EMAIL: hola@monstershop.eu

Para consultas sobre este dispositivo, la garantía, devoluciones o denuncias de fallos por favor use los siguientes detalles.

#### DEPARTAMENTO DE SOPORTE

TEL: 01347 878 887

EMAIL: help@monstershop.co.uk

Für Informationen bezüglich dieses Geräts oder anderer Produkte aus unserer Monster-Abteilung, benutzen sie die folgenden unten aufgeführten Angaben.

#### VERKAUFABTEILUNG

TEL: 01347 878 888

EMAIL: hallo@monstershop.eu

Für Fragen über dieses Gerät, die Garantie, Rückgaben oder bei Störungen, benutzen sie die folgenden unten aufgeführten Angaben.

#### SUPPORT-ABTEILUNG

TEL: 01347 878 887

EMAIL: help@monstershop.co.uk

Per informazioni riguardanti questo dispositivo o altri prodotti dalle categorie Monster utilizzare i dettagli sotto riportati.

#### DIPARTIMENTO VENDITE

TEL: 01347 878 888

EMAIL: ciao@monstershop.eu

Per domande riguardo dispositivo, garanzia, reso o per riferire di guasti, utilizzare i dettagli sotto riportati.

#### DIPARTIMENTO SUPPORTO

TEL: 01347 878 887

EMAIL: help@monstershop.co.uk

Monster House, Alan Farnaby Way,  
Sheriff Hutton Industrial Estate,  
Sheriff Hutton, York, YO60 6PG  
[www.monstershop.co.uk](http://www.monstershop.co.uk)



 Try **Monster**. Buy **Monster**. Be **Monster**. 