



Workbench with Drawer & Light

210762 / 210794 / 210795

INSTRUCTION MANUAL

www.monstershop.co.uk



SPECIFICATION

PRODUCT DESCRIPTION

Our Workbench with Drawer & Light is the perfect solution to your storage needs. Hang all your must-have tools on the pegboard which has 40 hooks included, so that they are never out of reach.

Featuring a LED lamp to keep your sturdy work area well lit with a large bottom shelf, handy drawer and upper shelf, this workbench's ample storage will keep your workspace spick and span!

PRODUCT SPECIFICS

WORKBENCH

MATERIAL: Powder Coated Steel & MDF
DIMENSIONS: 150cm (L) x 120cm (W) x 60cm (D)

WEIGHT CAPACITY

TOP SHELF: 30KG
WORK AREA: 200KG
BOTTOM SHELF: 100KG
DRAWER: 40KG

LED LIGHT

INPUT POWER: 9-10W
DIMENSIONS: 57.2cm (L) x 28cm (W) x 38cm (D)
FREQUENCY: 50/60Hz

SPECIFICATION

PRODUCT FEATURES

- A. Top Shelf
- B. LED Light
- C. Work Area
- D. Drawer
- E. Peg Board
- F. Bottom Shelf



Monster Group UK Limited's liability will be limited to the commercial value of the product only.

SPECIFICATION

PARTS LIST

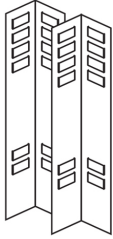

A Front Legs - x2



B Back Left Leg - x1



C Back Right Leg - x1

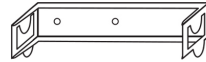

D Left Drawer Support - x1

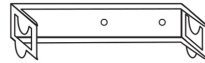

E Right Drawer Support - x1

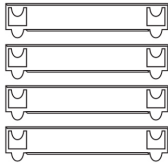

F Short Worktop Supports - x4

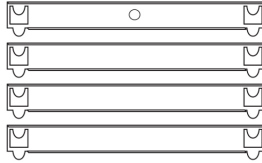

G Long Worktop Supports - x4



H Left Vertical Support - x1



I Right Vertical Support - x1



J1 Back Support



K Left Top Shelf Support - x1

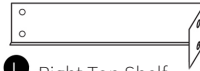

L Right Top Shelf Support - x1



J2 Front Support



M Drawer Front - x1

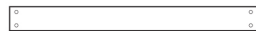

N Drawer Back - x1

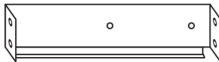

O Drawer Sides (Short) - x2



P Drawer Base - x1

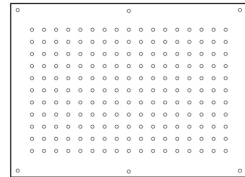

Q Peg Board - x1

Monster Group UK Limited's liability will be limited to the commercial value of the product only.

SPECIFICATION

PARTS LIST



R Bottom Shelf - x1



S Worktop - x1

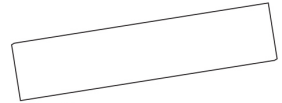

T Top Shelf - x1

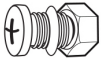

V Short Fixings - x30

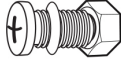

W Long Fixings - x6



X Nuts/Bolts (Small) - x18

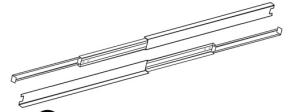

U Drawer Runners - x2

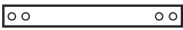

Y Pegboard Supports - x1

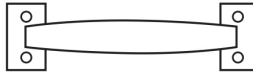

S1 Drawer Handles - x2

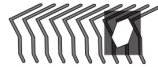

S2 Pegs - x40



S3 Cap Feet - x4

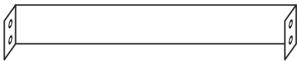

S4 Drawer Support - x1



S5 Support Bars - x2

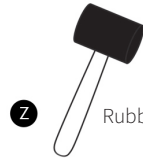

Z Rubber Mallet - x1

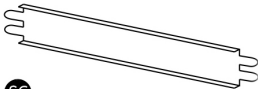

S6 Support Bars - x4

SAFETY ADVICE

SAFE WORKING PRACTICE

Please read through the Safe Working Practice to ensure prevention of injury or damage to the device.

- Do not use this product for anything other than its intended use.
- Always keep the weight evenly distributed to avoid damage to the workbench and to prevent the workbench from falling over.
- Do not alter or modify this product in any way.
- Keep your construction area clear of clutter.
- Use this product on a flat surface.
- Ensure children, pets or animals are not in the vicinity when constructing this workbench.
- Do not exceed the load bearing capacity shown in the product specifics on page 2.
- Regularly inspect the product for damage and sign of wear. Tighten any components that appear to be loose.
- Ensure the moulded feet are attached correctly to prevent any potential injury.
- We recommend two people to assemble the product.
- The LED light is only suitable for a connection to a 240V-50Hz supply.
- The LED light is for indoor use only.
- Under no circumstances should the LED light be covered with any material.
- Do not plug the LED light cable into the mains until it has been connected to the LED Light.
- Do not install the LED light where it will be close to a water source. It is not suitable for a bathroom location.
- If the mains cable becomes damaged in any way, do not attempt to use it. Contact our Customer Support Team about a replacement.
- Allow the LED Light to cool for 10 minutes before removing from the brackets or attempting to clean.

USER GUIDE

ASSEMBLY INSTRUCTIONS

In order to allow room for the tabs to fit securely, it is recommended that you gently prise the tabs open using a suitable flat head screwdriver (not supplied). Once the tabs have been inserted, gently tap shut using a suitable rubber mallet to secure.

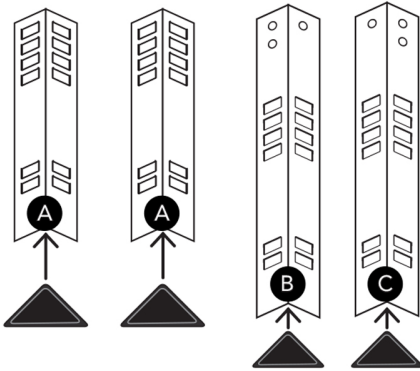

STEP 1:

Clip the 4 Cap Feet (S3) onto the ends of the Legs (A, B, C) as illustrated.

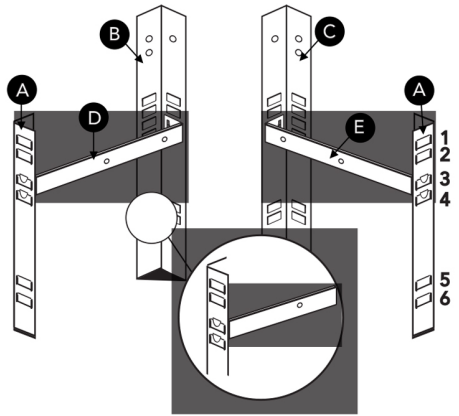

STEP 2:

Fit the Drawer Supports (D, E) between the Front and Back Legs (A, B, C) and secure as illustrated.

The Drawer Supports should be fitted between the 3rd and 4th slots and face outwards.

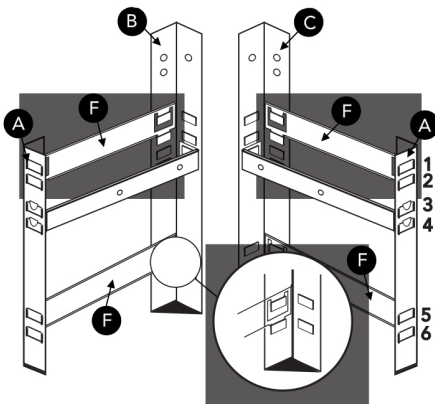

STEP 3:

Fit the 4 Worktop Supports (F) to the Front and Back Legs (A, B, C) as illustrated.

The Short Worktop Supports should be positioned between the 1st/2nd and 5th/6th slots.

USER GUIDE

ASSEMBLY INSTRUCTIONS

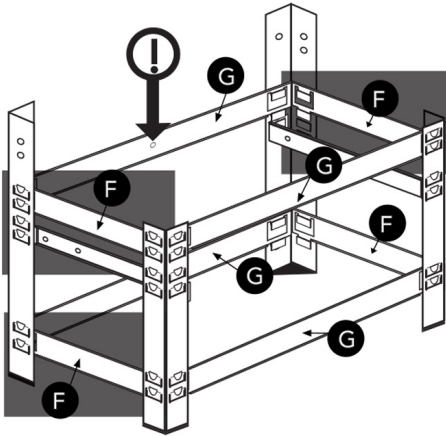

STEP 4:

Fit the 4 Long Worktop Supports (G) to the Front and Back Legs (A, B, C) at the 1st/2nd and 5th/6th slots.

The Long Worktop Support with the central hole should be positioned between the 1st/2nd slots on the Back Legs (B, C).

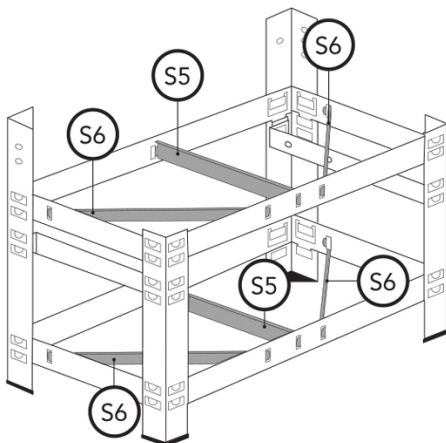

STEP 4.1:

Fit the supports (S5 & S6) to the frame.

STEP 5:

Bend the tabs on each end of the Support Bars (S5) to a 90° angle. Locate the slots at the top and bottom and slot into place between the Front & Rear Side Beams (G).

Bend the tabs back on themselves (as shown below) to attach.

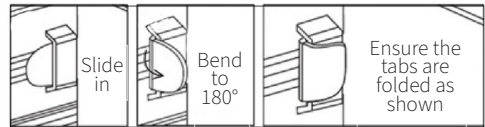

Fit the Left and Right Upper Vertical Supports (H, I) into the sides of the Back Legs (B, C).

Secure using 4 Short Fixings (V).

Tighten with a suitable spanner to secure. Secure the Support Bars (S5) into place using (W).

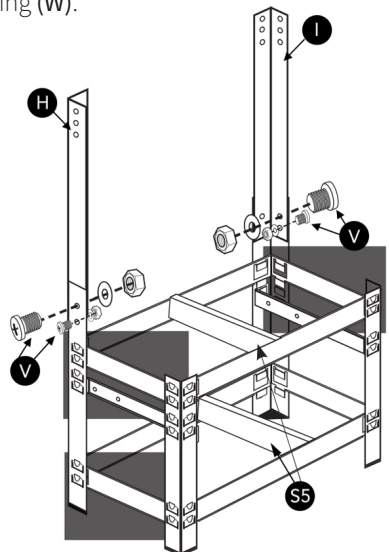

USER GUIDE

ASSEMBLY INSTRUCTIONS

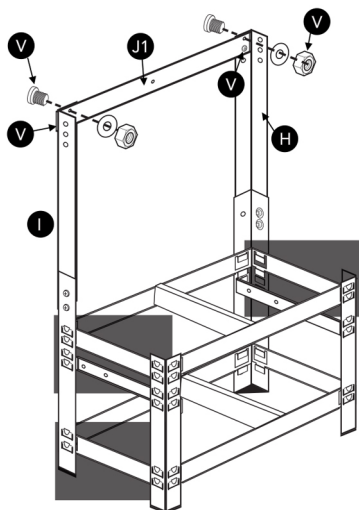

STEP 6:

Fix the Back Support (**J1**) to the top 2 holes of the Vertical Supports (**H, I**). Secure using 4 Short Fixings (**V**). Tighten to secure.

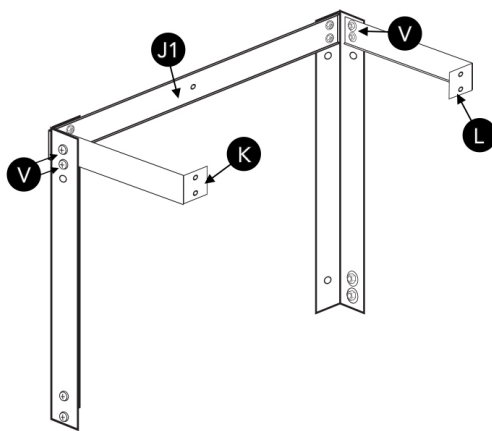

STEP 7:

Fix the longest edge of the Short Top Shelf Supports (**K, L**) to the top 2 holes of the Vertical Supports (**H, I**) using 4 Short Fixings (**V**) as illustrated. Tighten to secure.

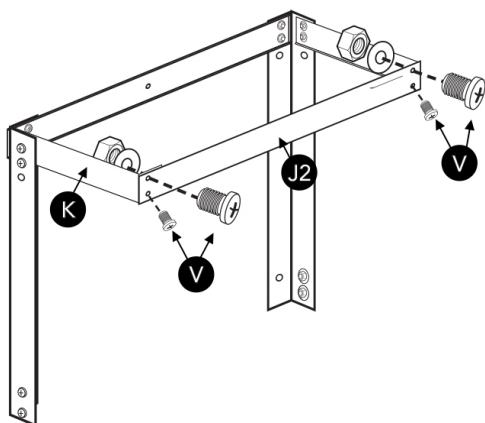

STEP 8:

Fix the Front Support (**J2**) to the front of the Short Top Shelf Supports (**K, L**) using 4 Short Fixings (**V**) as illustrated. Tighten to secure.

USER GUIDE

ASSEMBLY INSTRUCTIONS

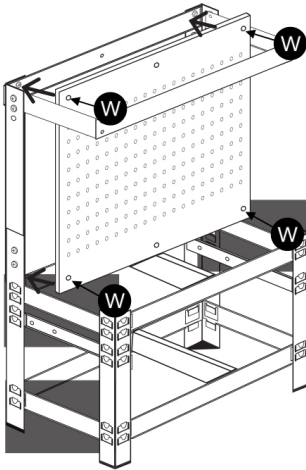

STEP 9:

Fix Peg Board (Q) with 4 Long Fixings (W). Tighten to secure.

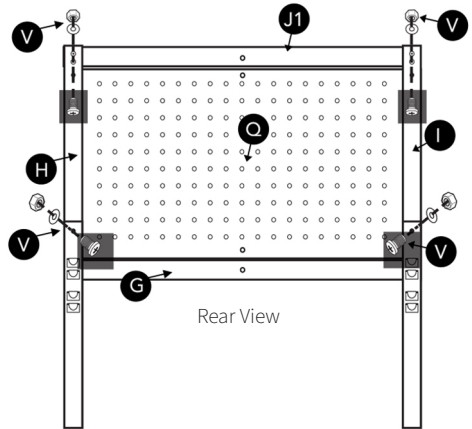

STEP 10:

From the rear, insert 4 Short Fixings (V) into the vacant holes in the Vertical Supports (H, I). Tighten to secure.

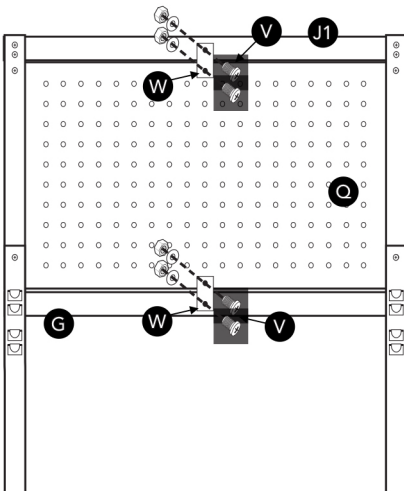

STEP 11:

Using 2 Short Fixings (V), attach the Pegboard Supports (Y) to the rear of the assembly through the vacant holes on the Long Supports (G, J1).

Insert 2 Long Fixings (W) into the vacant holes on the Pegboard Supports (Y) and into the Pegboard (Q). Tighten all to secure.

USER GUIDE

ASSEMBLY INSTRUCTIONS

STEP 12:

Fix the 2 Drawer Handles (**S1**) to the Drawer Front (**M**) by inserting 8 Small Nuts/Bolts (**X**) from the outside in towards the ledge. Tighten to secure.

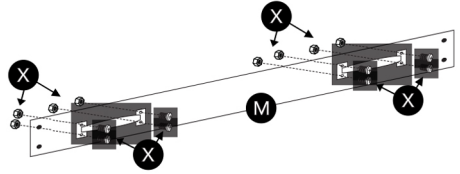

STEP 13:

Fix the Short Drawer Sides (**O**) to the Drawer Front (**M**) using 4 Short Fixings (**V**). Tighten to secure.

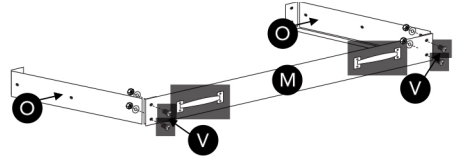

STEP 14:

Lower the Drawer Base (**P**) into the Drawer Assembly to rest on the inner ledges. Fix the Long Drawer Back (**N**) to the assembly using 4 Short Fixings (**V**).

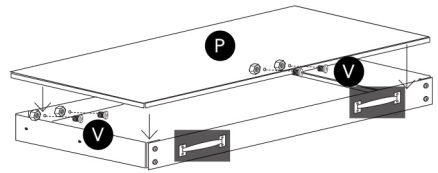

STEP 15:

Fix the 2 Drawer Runners (**U**) to the Short Drawer Sides (**O**) using 4 Small Nuts/Bolts (**X**) through the available holes as illustrated. Tighten to secure.

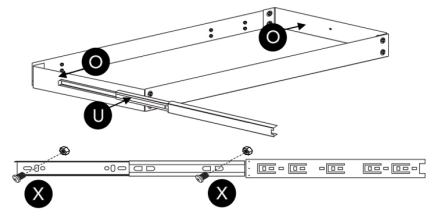

STEP 16:

Holding the drawer within the Workbench assembly, extend and align the Drawer Runners (**U**) with the fixing holes in the Drawer Supports (**D, E**). Insert 4 Small Fixings (**X**) through the Runners and into the Supports. Tighten to secure.

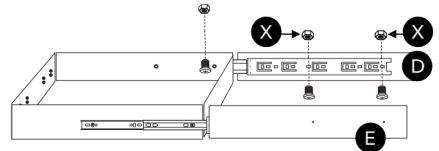

Insert the Drawer Support (**S4**) into the centre of the drawer and secure in place using (**W**).

USER GUIDE

ASSEMBLY INSTRUCTIONS

STEP 17:

Fit the Worktop (S) and Bottom Shelf (R) by gently lowering them into the appropriate levels on the Workbench as illustrated.

ADDITIONAL: Insert Pegs (S2) into the Pegboard (Q) to hang tools for convenience.

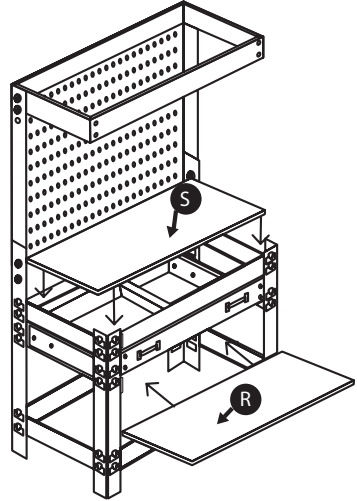

STEP 18:

Fit the Top Shelf (T) by placing it on top of the frame and securing in place with 2 Small Nuts /Bolts (X).

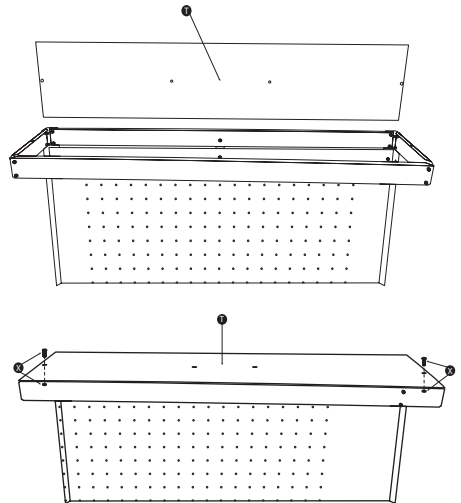
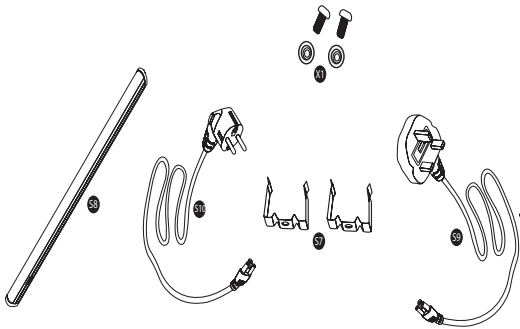

USER GUIDE

ASSEMBLY INSTRUCTIONS

STEP 19:

Now fit the LED Light Brackets (S7) to the underside of the Top Shelf (T) using the 2 X-Small Nuts/Bolts (X1).

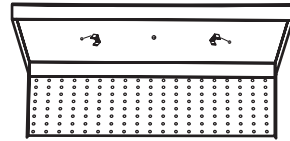
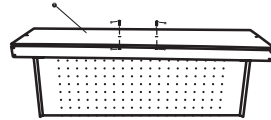

STEP 20:

Next insert either the UK (S9) or EU (S10) into the LED Light (S8).

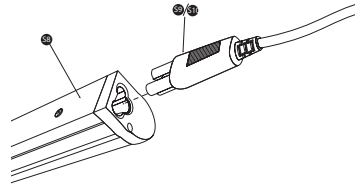

STEP 21:

Push the LED Light (S8) into the brackets (S7) already fitted under the top shelf until they click into place.

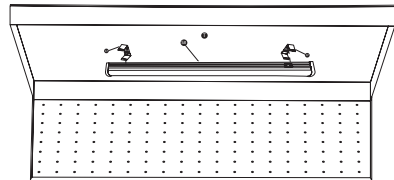

STEP 22:

Feed the excess cable through the closest hole on the pegboard so it is out of the way of your workspace.

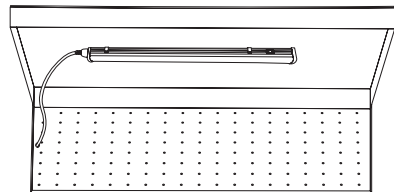

USER GUIDE

MAINTENANCE

- Treat the MDF boards with varnish or mould prevention products if using in a humid environment.
- Allow the LED Light to cool for 10 minutes before removing from the brackets or attempting to clean. Clean the LED Light with a dry cloth only.

TROUBLESHOOTING

RESOLUTION GUIDE

WHAT DO I DO IF THERE ARE MISSING PARTS FROM MY ORDER?

If there appears to be any part missing from your order, contact our friendly and helpful Customer Support Team within 7 days of receipt.

**FOR ALL OTHER ISSUES, PLEASE CONTACT OUR
CUSTOMER SUPPORT TEAM.**

SPÉCIFICATIONS

DESCRIPTION DU PRODUIT

Notre établi à tiroir et éclairage sera parfait pour tous vos besoins de rangement.

Accrochez tous vos outils indispensables sur la paroi porte-outils équipée de 40 crochets, pour un accès direct et facile.

Doté d'un éclairage LED pour éclairer votre zone de travail, d'une grande étagère inférieure, d'un tiroir pratique et d'une étagère supérieure, cet établi offre un grand espace de rangement pour vous permettre de garder votre espace de travail propre et bien organisé !

SPÉCIFICATIONS DU PRODUIT

ÉTABLI

MATÉRIAU :	Acier thermolaqué et MDF
DIMENSIONS :	150cm (L) x 120cm (W) x 60cm (D)

CAPACITÉ DE CHARGE

ÉTAGÈRE SUPÉRIEURE :	30KG
PLAN DE TRAVAIL :	200KG
ÉTAGÈRE INFÉRIEUR :	100KG
TIROIR :	40KG

ÉCLAIRAGE LED

PUISSANCE D'ENTRÉE :	9-10W
DIMENSIONS :	57.2cm (L) x 28cm (W) x 38cm (D)
FRÉQUENCE :	50/60Hz

SPÉCIFICATIONS

CARACTÉRISTIQUES DU PRODUIT

- A. Étagère supérieure
- B. Éclairage LED
- C. Plan de travail

- D. Tiroir
- E. Paroi porte-outils
- F. Étagère inférieure



La responsabilité de Monster Group UK Limited sera limitée à la valeur commerciale du produit.

SPÉCIFICATIONS

LISTE DES PIÈCES

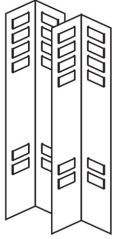

A Pieds avants - x2



B Pied arrière gauche - x1



C Pied arrière droite - x1

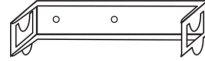

D Support tiroir gauche - x1

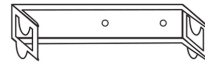

E Support tiroir droite - x1

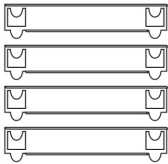

F Supports courts plan de travail - x4

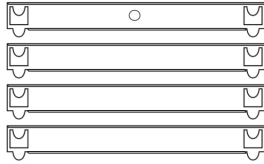

G Supports longs plan de travail - x4



H Support vertical gauche - x1



I Support vertical droite - x1



J1 Support arrière - x1



K Support plateau supérieur gauche - x1



L Support plateau supérieur droite - x1



J2 Support avant - x1



M Avant tiroir - x1



N Arrière tiroir - x1

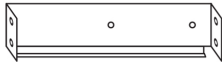

O Côtés tiroirs (court) - x2

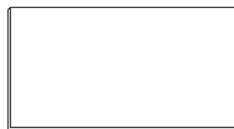

P Base tiroir - x1

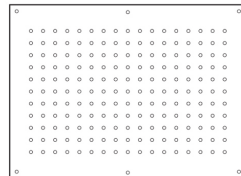

Q Paroi Perforée - x1

La responsabilité de Monster Group UK Limited sera limitée à la valeur commerciale du produit.

SPÉCIFICATIONS

Liste des pièces



R Plateau inférieur - x1



S Plan de travail - x1

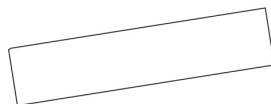

T Plateau supérieur - x1



V Visseries courtes
= x80



W Visseries longues



X Écrous/boulons (petits)
- x16

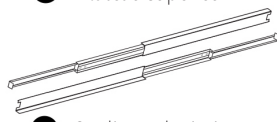

U Coulisses de tiroir - x2



Y Supports de paroi
perforée - x1

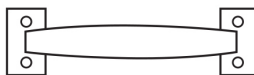

S1 Poignées de tiroir - x2



S2 Chevilles - x40



S3 Tampons de pieds - x4

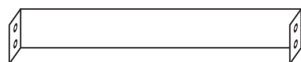

S4 Support tiroir - x1



S5 Barres de soutien - x2

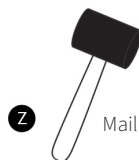

Z Maillet en caoutchouc - x1

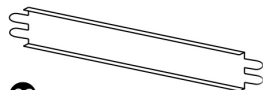

S6 Barres de soutien - x4

X1 – Écrous/Boulons (X-Small)

S9 - Câble d'éclairage LED
pour le Royaume-Uni

S7 – Supports pour éclairage
LED

S10 – Câble d'éclairage LED
pour l'UE

S8 – Éclairage LED

CONSEILS DE SÉCURITÉ

PRATIQUE DE TRAVAIL SÉCURITAIRE

Veillez lire les consignes de sécurité afin d'éviter toute blessure ou tout dommage sur l'appareil.

- N'utilisez pas ce produit à d'autres fins que celles pour lesquelles il a été conçu.
- Veillez à ce que le poids soit toujours bien réparti afin d'éviter d'endommager l'établi ou que celui-ci ne bascule.
- Ne pas modifier ce produit de quelque manière que ce soit.
- Veillez à ce que votre plan de travail soit exempt de tout encombrement.
- Utilisez ce produit sur une surface plane.
- Assurez-vous que les enfants ou les animaux domestiques ne se trouvent pas à proximité lorsque vous assemblerez cet établi.
- Ne dépassez pas la capacité de charge indiquée dans les caractéristiques du produit indiqués en page 2.
- Inspectez régulièrement le produit pour détecter tout signe d'usure ou de dommage. resserrez tous les composants qui semblent lâches.
- Assurez-vous que les pieds soient correctement fixés afin d'éviter tout risque de blessure.
- Nous vous conseillons d'être à deux personnes pour assembler le produit.
- L'éclairage LED ne peut être raccordé qu'à une alimentation de 240V-50Hz.
- L'éclairage LED est destiné à un usage intérieur uniquement.
- Ne recouvrez jamais L'éclairage LED d'un quelconque matériau.
- Ne branchez pas le câble de l'éclairage sur le secteur avant de l'avoir connecté à l'éclairage LED.
- N'installez pas l'éclairage dans un endroit proche d'une source d'eau. Celui-ci n'est pas adapté à être installé dans une salle de bain.
- Si le câble d'alimentation est endommagé de quelque manière que ce soit, n'essayez pas de l'utiliser. Veuillez contacter notre équipe du service client pour procéder à un remplacement.

MODE D'EMPLOI

INSTRUCTIONS DE MONTAGE

Afin de laisser de la place pour les languettes, il est recommandé de les ouvrir doucement à l'aide d'un tournevis à tête plate approprié (non fourni). Une fois les languettes insérées, fermez-les doucement en tapotant avec un maillet en caoutchouc approprié pour les fixer.

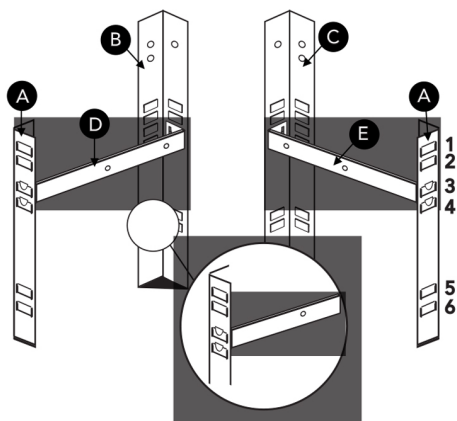
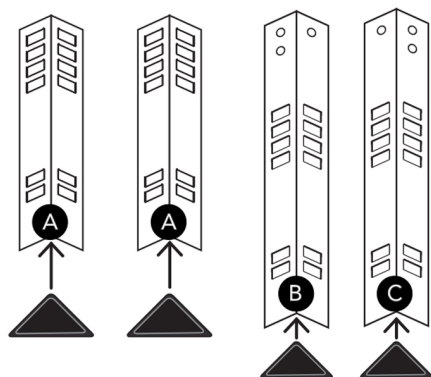

ÉTAPE 1:

Clipsez les 4 tampons de pieds (S3) sur les extrémités des pieds (A, B, C) comme illustré.

ÉTAPE 2:

Placez les supports de tiroir (D, E) entre les pieds avant et arrière (A, B, C) et fixez-les comme illustré.

Les supports de tiroir doivent être placés entre les 3e et 4e fentes et être orientés vers l'extérieur.

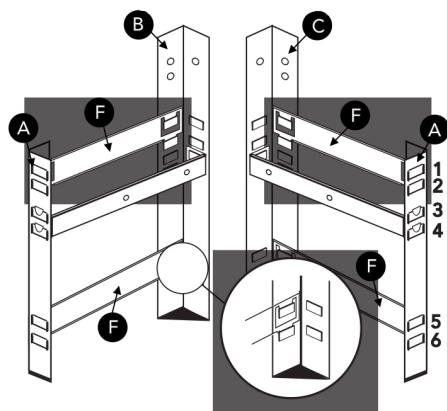

ÉTAPE 3:

Montez les 4 supports de plan de travail (F) sur les pattes avant et arrière (A, B, C) comme illustré.

Les supports de plan de travail courts doivent être placés entre les emplacements 1/2 et 5/6.

MODE D'EMPLOI

INSTRUCTIONS DE MONTAGE

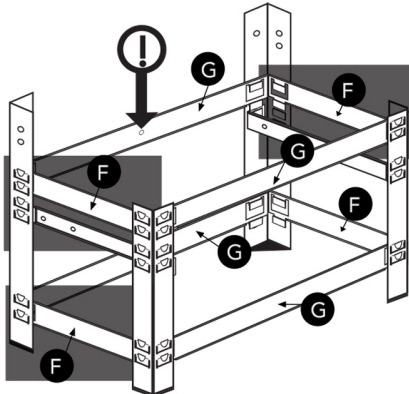

ÉTAPE 4:

Fixez les 4 longs supports de plan de travail (S5) aux pieds avant et arrière (A, B, C) aux emplacements 1/2 et 5/6.

Le support de plan de travail long avec le trou central doit être placé entre les fentes 1 et 2 des pieds arrière (B, C).

1st/2nd slots on the Back Legs (B, C).

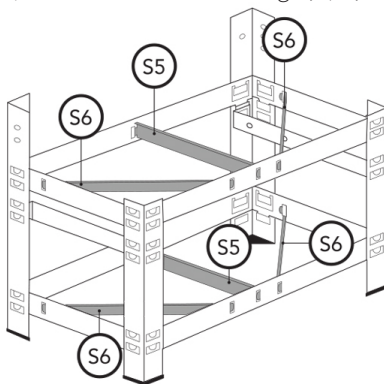

ÉTAPE 4.1:

Fixez les supports (S5 et S6) au cadre.

ÉTAPE 5:

Piez les languettes à chaque extrémité des barres de support (S5) à un angle de 90°. Repérez les fentes en haut et en bas et mettez-les en place entre les poutres latérales avant et arrière (G).

Repliez les languettes sur elles-mêmes (comme indiqué ci-dessous) pour les attacher.

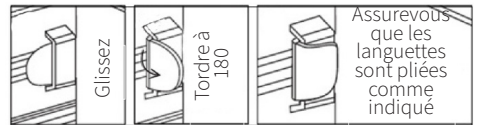

Fit the Left and Right Upper Vertical Placez les supports verticaux supérieurs gauche et droit (H, I) sur les côtés des pieds arrière (B, C).

Sécurisez à l'aide de 4 vis courtes (V). Serrez avec une clé appropriée pour sécuriser. Fixez les barres de soutien (S5) en place à l'aide de (W).

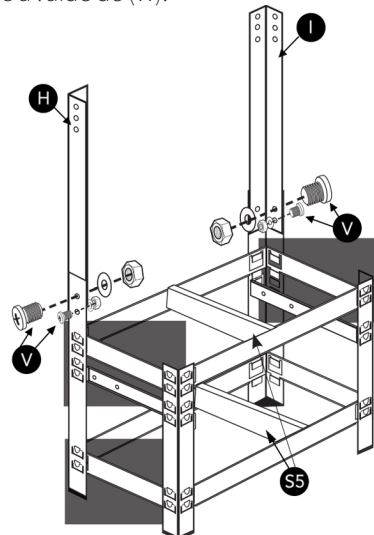

MODE D'EMPLOI

INSTRUCTIONS DE MONTAGE

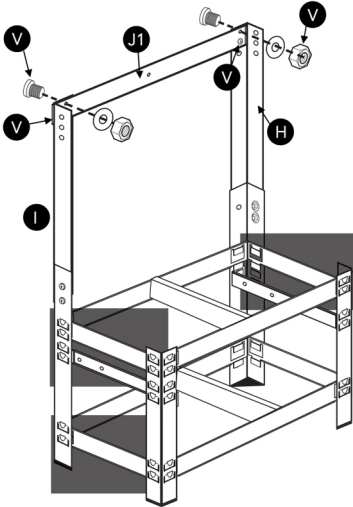

ÉTAPE 6:

Fixez le support dorsal (J1) au sommet 2 trous des supports verticaux (H, I). Fixez à l'aide de 4 vis courtes (V). Serrez pour sécuriser.

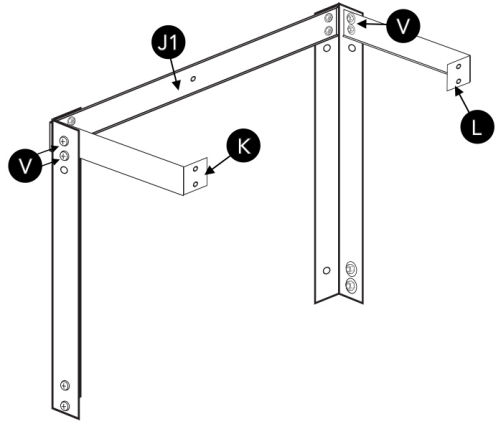

ÉTAPE 7:

Fixez le bord le plus long des supports courts du plateau supérieur (K, L) aux deux trous supérieurs des supports verticaux (H, I) à l'aide de quatre vis courtes (V), comme illustré. Serrez pour sécuriser.

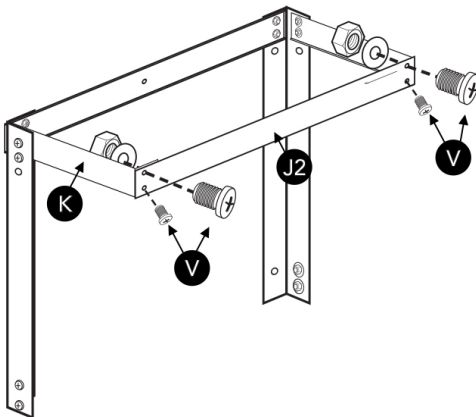

ÉTAPE 8:

Fixez le support avant (J2) à l'avant des supports courts du plateau supérieur (K, L) à l'aide de 4 vis courtes (V) comme illustré. Serrez pour sécuriser.

MODE D'EMPLOI

INSTRUCTIONS DE MONTAGE

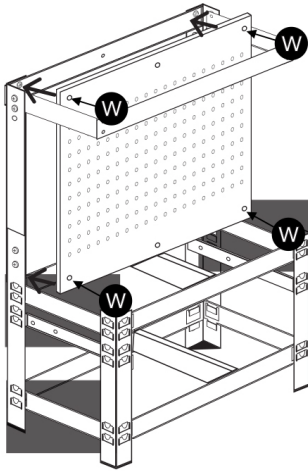

ÉTAPE 9:

Fixez la paroi perforée (Q) avec 4 vis longues (W). Serrez pour sécuriser.

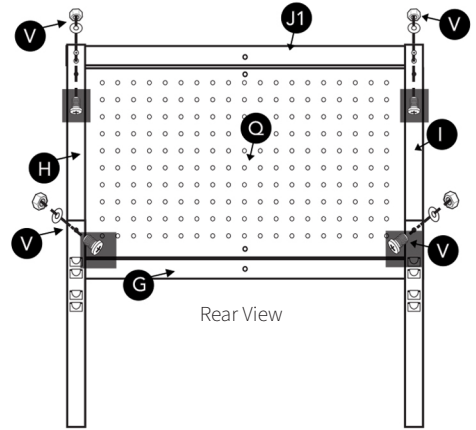

ÉTAPE 10:

Par l'arrière, insérez 4 vis courtes (V) dans les trous libres des supports verticaux (H, I). Serrez pour sécuriser.

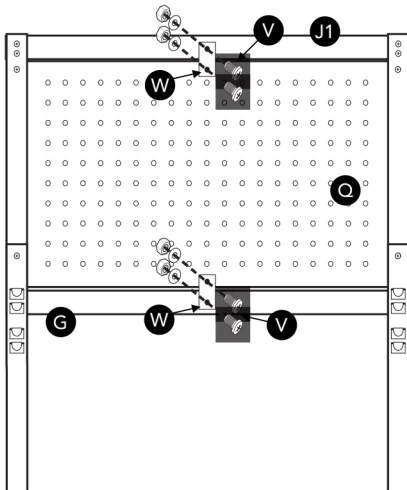

ÉTAPE 11:

À l'aide de deux vis courtes (V), fixez la paroi perforée (Y) à l'arrière de l'ensemble par les trous libres des supports longs (G, J1).

Insérez 2 vis longues (W) dans les trous libres des supports du paroi perforée (Y) et dans la paroi perforée (Q). Serrez tout pour fixer.

MODE D'EMPLOI

INSTRUCTIONS DE MONTAGE

ÉTAPE 12:

Fixez les 2 poignées de tiroir (S1) à la façade de tiroir (M) en insérant 8 petits écrous/boulons (X) de l'extérieur vers l'intérieur en direction du rebord. Serrez pour sécuriser.

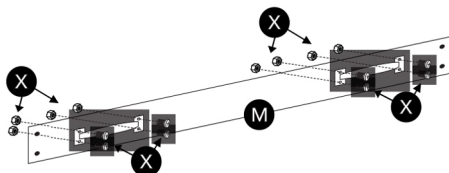

ÉTAPE 13:

Fixez les côtés courts du tiroir (O) à la façade de tiroir (M) à l'aide de 4 vis courtes (V). Serrez pour sécuriser.

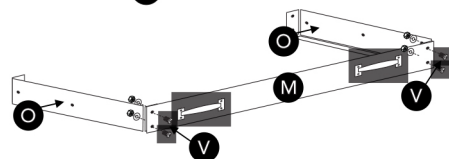

ÉTAPE 14:

Abaissez le fond du tiroir (P) dans l'ensemble du tiroir pour qu'il repose sur les rebords intérieurs. Fixez le fond de tiroir long (N) à l'ensemble à l'aide de 4 vis courtes (V).

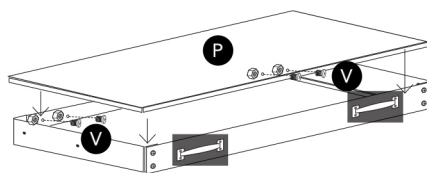

ÉTAPE 15:

Fixez les 2 glissières de tiroir (U) sur les côtés courts du tiroir (O) à l'aide de 4 petits écrous/boulons (X) à travers les trous disponibles comme illustré. Serrez pour sécuriser.

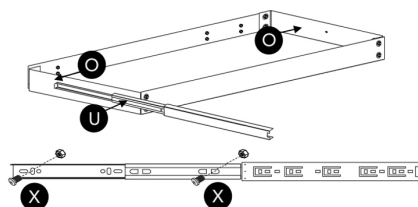

ÉTAPE 16:

En tenant le tiroir dans l'ensemble Workbench, sortez et alignez les glissières de tiroir (U) avec les trous de fixation des supports de tiroir (D, E). Insérez 4 petites vis (X) à travers les glissières et dans les supports. Serrez tout pour fixer.

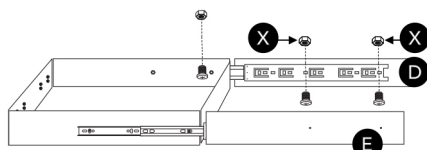

Insérez le support de tiroir (S4) au centre du tiroir et fixez-le en place à l'aide de (W).

MODE D'EMPLOI

INSTRUCTIONS DE MONTAGE

ÉTAPE 17:

Montez le plateau supérieur (T), le plan de travail (S) et le plateau inférieur (R) en les abaissant doucement aux niveaux appropriés sur l'établi, comme illustré.

ADDITIONNEL : Insérez des chevilles (S2) dans la paroi perforée (Q) pour accrocher les outils.

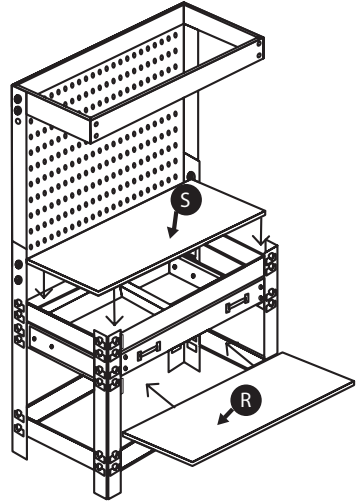

ÉTAPE 18:

Installez l'étagère supérieure (T) en la plaçant sur le dessus du cadre et en la fixant avec 2 petits écrous / boulons (X).

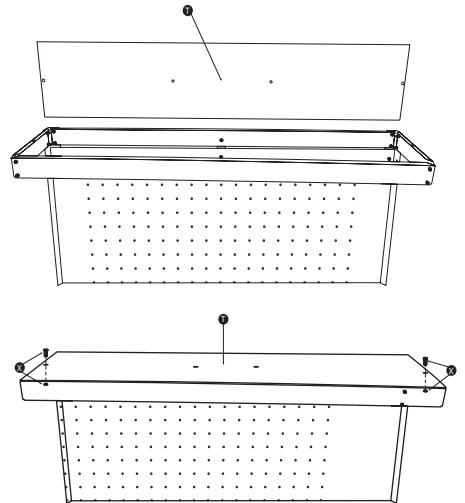
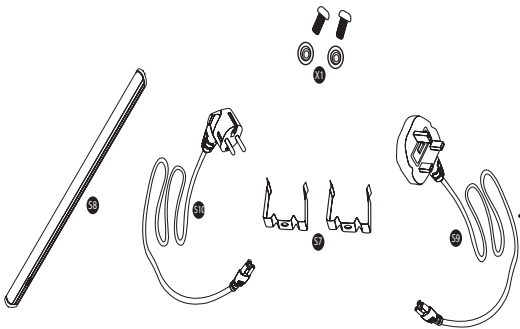

MODE D'EMPLOI

INSTRUCTIONS DE MONTAGE

ÉTAPE 19:

Installez maintenant les supports d'éclairage LED (S7) sur la face inférieure de l'étagère supérieure (T) à l'aide de 2 petits écrous/ boulons (X1).

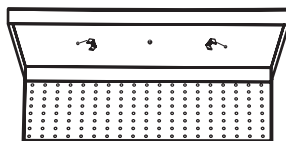
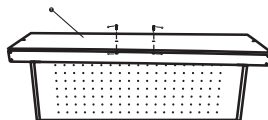

ÉTAPE 20:

Ensuite, insérez le câble UK (S9) ou EU (S10) dans l'éclairage LED (S8).

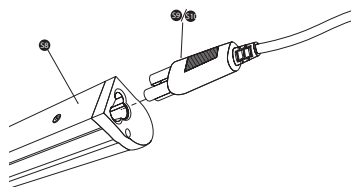

ÉTAPE 21:

Insérez l'éclairage LED (S8) en les enclenchant dans les supports (S7) déjà installés sous l'étagère supérieure.

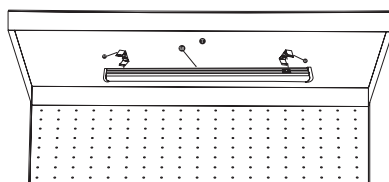

ÉTAPE 22:

Faites passer l'excédent de câble par l'orifice le plus proche de la paroi porte-outils afin qu'il ne gêne pas votre espace de travail.

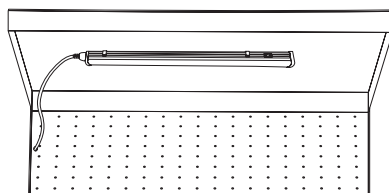

MODE D'EMPLOI

ENTRETIEN

- Traitez les panneaux MDF avec du vernis ou des produits anti-moisissure si vous les utilisez dans un environnement humide.
- Laissez l'éclairage LED refroidir pendant 10 minutes avant de le retirer de ses supports ou pour le nettoyer. Nettoyez l'éclairage LED avec un chiffon sec uniquement.

DÉPANNAGE

GUIDE DE RÉOLUTION

QUE FAIRE S'IL MANQUE DES PIÈCES À MA COMMANDE?

S'il semble manquer des pièces à votre commande, contactez notre équipe du service client dans les 7 jours suivant la réception.

**POUR TOUT AUTRE PROBLÈME, VEUILLEZ
CONTACTER NOTRE ÉQUIPE DU SERVICE CLIENT.**

SPEZIFIKATIONEN

PRODUKTBESCHREIBUNG

Unsere Werkbank mit einer Schublade und Licht ist die perfekte Lagerlösung. Sie können alle Ihre Werkzeuge griffbereit mit den mitgelieferten Haken an der Stecktafel aufbewahren.

Mit der mitgelieferten LED-Lampe ist Ihre Arbeitsfläche gut beleuchtet und dank der unteren Ablage, der Schublade und der oberen Ablage ist Ihre Arbeitsfläche immer Arbeitsbereit.

PRODUKTSPEZIFIKA

WERKBANK

MATERIAL: Pulverbeschichteter Stahl & MDF
ABMESSUNG: 150cm (L) x 120cm (B) x 60cm (T)

GEWICHTSKAPAZITÄT

OBERE ABLAGE: 30KG
ARBEITSFLÄCHE: 200KG
UNTERE ABLAGE: 100KG
SCHUBLADE: 40KG

LED-LAMPE

NENNLEISTUNGS-AUFNAHME: 9-10W
ABMESSUNG: 57.2cm (L) x 28cm (B) x 38cm (T)
FREQUENZ: 50/60Hz

SPEZIFIKATION

PRODUKTMERKMALE

- A. Obere Ablage
- B. LED-Lampe
- C. Arbeitsfläche
- D. Schublade
- E. Stecktafel
- F. Untere Ablage



Die Haftung von Monster Group UK Limited ist auf den Handelswert des Produkts beschränkt.

SPEZIFIKATIONEN

LISTE DER TEILE



A Vordere Beine- x2

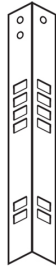

B Hint. link. Bein- x1



C Hint. rech. Bein- x1



D Linke Schubladenstütze- x1

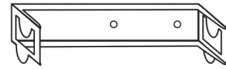

E Rechte Schubladenstütze- x1

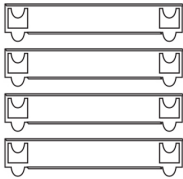

F Kurze Arbeitsplatte halterung- x4

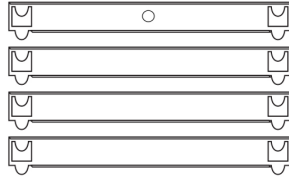

G Lange Arbeitsplatte halterung- x4



H Linke vertikale Stütze- x1



I Rechte vertikale Stütze- x1



J1 Rückenstütze



K L. obere Fachbodenstütze - x1



L R. obere Fachbodenstütze - x1



J2 Vordere Stütze



M Schubladenfront- x1



N Rückseite Schublade- x1

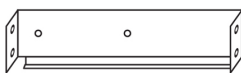

O Schubladenseiten (kurz) - x2



P Schubladenboden- x1

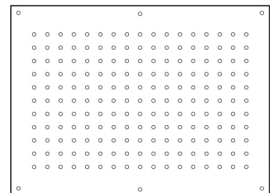

Q Pinnwand - x1

SPEZIFIKATIONEN

LISTE DER TEILE



R Unteres Regal - x1



S Arbeitsfläche - x1

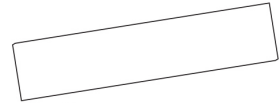

T Oberes Regal - x1

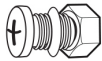

V Kurze Befestigungen - x30

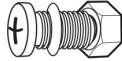

W Lange Befestigungen - x6

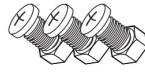

X Muttern/Schrauben (klein) - x16

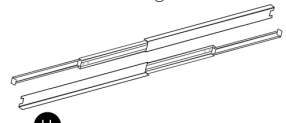

U Schubladenschienen - x2

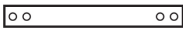

Y Pinwandstütze - x1

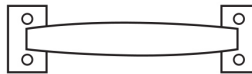

S1 Schubladengriffe - x2

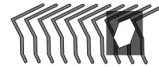

S2 Stifte - x40



S3 Kappenfüße - x4



S4 Schubladenstütze - x1



S5 Stützstäbe - x2



Z Gummihammer - x1

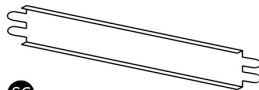

S6 Stützstäbe - x4

X1 – Muttern & Bolzen (X-Small)

S9 - UK LED-Lampe-Kabel

S7 – LED-Lampe Halterung

S10 – EU LED-Lampe-Kabel

S8 –LED-Lampe

SICHERHEITSHINWEIS

SICHERES ARBEITEN

Bitte lesen Sie sich die Hinweise zum sicheren Arbeitsverfahren durch, um Verletzungen oder Schäden am Gerät zu vermeiden.

- Verwenden Sie dieses Produkt nicht für andere als die vorgesehenen Zwecke.
- Achten Sie auf eine gleichmäßige Gewichtsverteilung, um Schäden an der Werkbank zu vermeiden und das Umfallen der Werkbank zu verhindern.
- Dieses Produkt darf in keiner Weise modifiziert oder umgebaut werden.
- Halten Sie Ihren Arbeitsbereich frei von Unordnung.
- Verwenden Sie dieses Produkt auf einer ebenen Fläche.
- Achten Sie darauf, dass Kinder, Haustiere oder Tiere beim Aufbau dieser Werkbank nicht in der Nähe sind.
- Die in den Produktspezifikationen auf Seite 2 angegebene Gewichtskapazität darf nicht überschritten werden.
- Überprüfen Sie das Produkt regelmäßig auf Schäden und Gebrauchsspuren. Ziehen Sie alle losen Teile fest.
- Achten Sie darauf, dass die geformten Füße richtig angebracht sind, um Verletzungen zu vermeiden.
- Wir empfehlen zwei Personen für den Zusammenbau des Produkts.
- Die LED-Lampe ist nur für den Anschluss an eine 240V-50Hz Versorgung geeignet.
- Die LED-Leuchte ist nur für den Innenbereich geeignet.
- Die LED-Lampe darf unter keinen Umständen mit irgendwelchen Materialien abgedeckt werden.
- Schließen Sie das Kabel der LED-Lampe erst an das Stromnetz an, nachdem Sie es mit der LED-Lampe verbunden haben.
- Installieren Sie die LED-Lampe nicht in der Nähe einer Wasserquelle. Sie ist nicht für ein Badezimmer geeignet.
- Sollte das Netzkabel in irgendeiner Weise beschädigt sein, versuchen Sie nicht, es zu benutzen. Wenden Sie sich bezüglich eines Ersatzes an unser Kundendienstteam.
- Lassen Sie die LED-Lampe 10 Minuten lang abkühlen, bevor Sie sie aus der Halterung nehmen oder versuchen, sie zu reinigen.

BENUTZERGUIDE

MONTAGEANLEITUNG

Um Platz für den sicheren Sitz der Laschen zu schaffen, empfiehlt es sich, die Laschen mit einem geeigneten Schlitzschraubendreher (nicht mitgeliefert) vorsichtig aufzudrücken. Nach dem Einsetzen der Laschen mit einem geeigneten Gummihammer vorsichtig zuschlagen, um sie zu sichern.

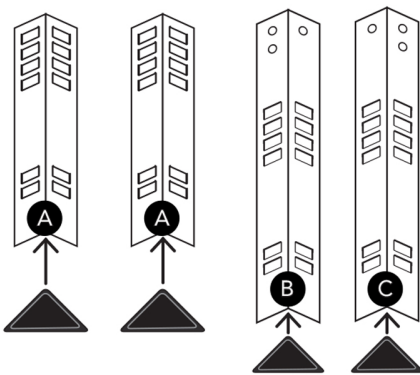

SCHRITT 1:

Stecken Sie die 4 Kappenfüße (S3) wie abgebildet auf die Enden der Beine (A, B, C).

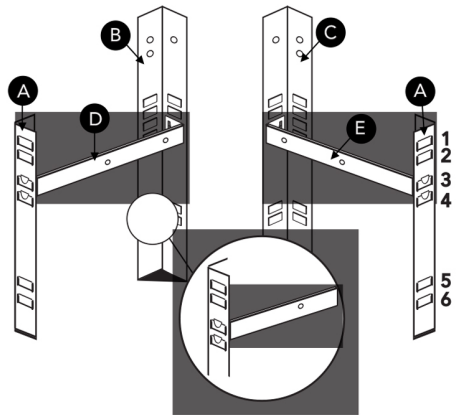

SCHRITT 2:

Bringen Sie die Schubladenstützen (D, E) zwischen den Vorder- und Hinterbeinen (A, B, C) an und befestigen Sie sie wie abgebildet.

Die Schubladenstützen sollten zwischen dem dritten und vierten Schlitz angebracht werden und nach außen zeigen.

SCHRITT 3:

Bringen Sie die 4 Arbeitsplattenstützen (F) wie abgebildet an den Vorder- und Hinterbeinen (A, B, C) an.

Die kurzen Arbeitsplattenstützen sollten zwischen dem ersten/zweiten und fünften/sechsten Schlitz positioniert werden.

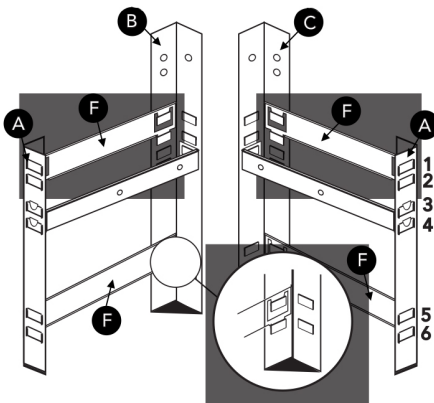

BENUTZERGUIDE

MONTAGEANLEITUNG

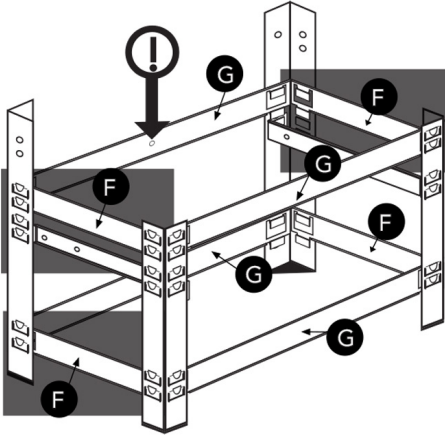

SCHRITT 4:
 Bringen Sie die 4 langen Arbeitsplattenstützen (G) an den Vorder- und Hinterbeinen (A, B, C) am 1./2. und 5./6. Schlitz an.

Die lange Arbeitsplattenstütze mit dem zentralen Loch sollte zwischen dem ersten und zweiten Schlitz an den hinteren Beinen (B, C) positioniert werden.

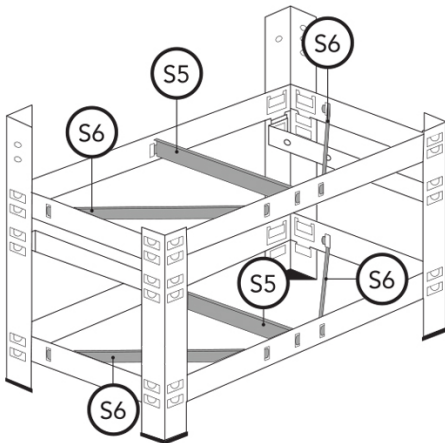

SCHRITT 4.1:
 Bringen Sie die Stützen (S5 & S6) am Rahmen an.

SCHRITT 5:

Biegen Sie die Laschen an jedem Ende der Stützstäbe (S5) in einem Winkel von 90°. Positionieren Sie die Schlitz oben und unten und schieben Sie sie zwischen die vorderen und hinteren Seitenbalken (G).

Biegen Sie die Laschen zur Befestigung wieder auf sich selbst zurück (wie unten abgebildet).

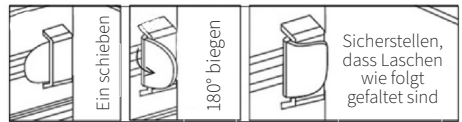

Bringen Sie die linke und rechte obere vertikale Stütze (H, I) an den Seiten der Hinterbeine (B, C) an.

Mit 4 kurzen Befestigungen (V) sichern.

Zur Sicherung mit einem geeigneten Schraubenschlüssel anziehen. Sichern Sie die Stützstäbe (S5) mit (W).

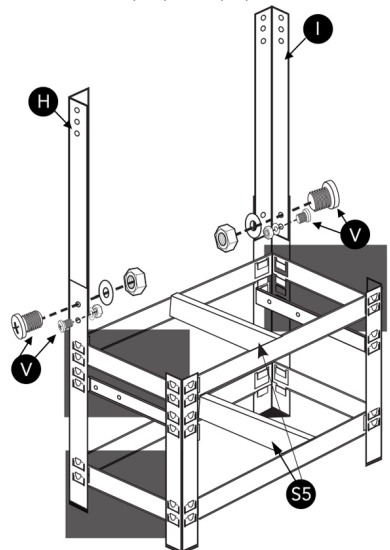

BENUTZERGUIDE

MONTAGEANLEITUNG

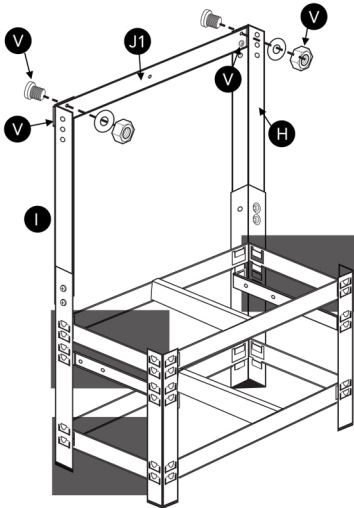

SCHRITT 6:

Befestigen Sie die Rückenstütze (J1) oben 2 Löcher der Vertikalstützen (H, I). Sichern mit 4 Kurzbefestigungen (V). Zur Sicherung festziehen.

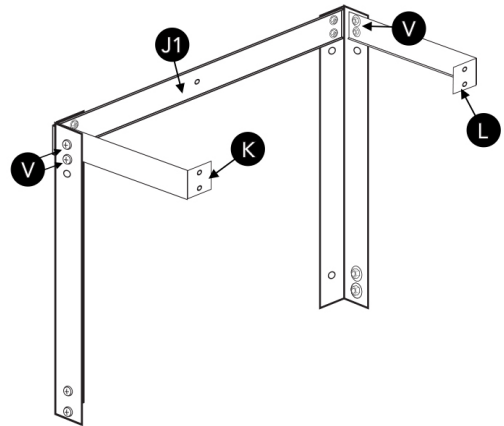

SCHRITT 7:

Befestigen Sie die längste Kante der kurzen oberen Fachbodenstützen (K, L) an den oberen 2 Löchern der vertikalen Stützen (H, I) mit 4 kurzen Befestigungen (V) wie abgebildet. Zur Sicherung festziehen.

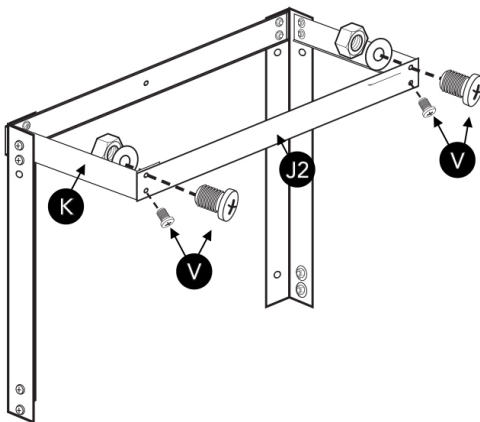

SCHRITT 8:

Befestigen Sie die vordere Stütze (J2) an der Vorderseite der kurzen oberen Fachbodenstützen (K, L) mit 4 kurzen Befestigungen (V) wie abgebildet. Zur Sicherung festziehen.

BENUTZERGUIDE

MONTAGEANLEITUNG

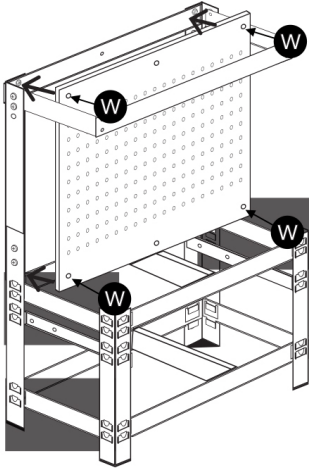

SCHRITT 9:

Befestigen Sie die Pinwand (Q) mit 4 langen Dübeln (W). Zum Sichern festziehen.

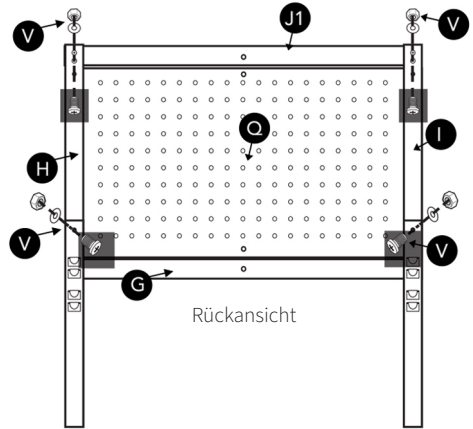

SCHRITT 10:

Führen Sie von hinten 4 kurze Dübel (V) in die freien Löcher in den Vertikalstützen (H, I) ein. Zur Befestigung anziehen.

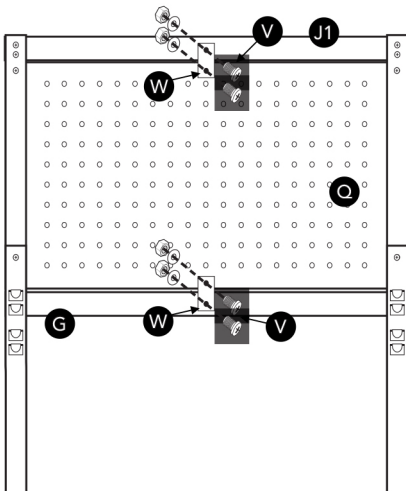

SCHRITT 11:

Befestigen Sie die Pinnwandträger (Y) mit 2 kurzen Befestigungen (V) an der Rückseite der Baugruppe durch die freien Löcher an den langen Trägern (G, J1).

Stecken Sie 2 lange Befestigungen (W) in die freien Löcher an den Pinnwandträger (Y) und in die Stecktafel (Q). Ziehen Sie alle zur Befestigung an.

BENUTZERGUIDE

MONTAGEANLEITUNG

SCHRITT 12:

Befestigen Sie die 2 Schubladengriffe (S1) an der Schubladenfront (M), indem Sie 8 kleine Muttern/Schrauben (X) von außen nach innen in Richtung der Leiste einführen. Zur Sicherung festziehen.

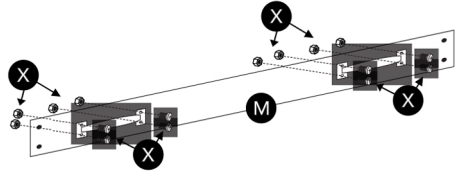

SCHRITT 13:

Befestigen Sie die kurzen Schubladenseiten (O) an der Schubladenfront (M), indem Sie 4 kurze Befestigungen (V) verwenden. Zur Sicherung festziehen.

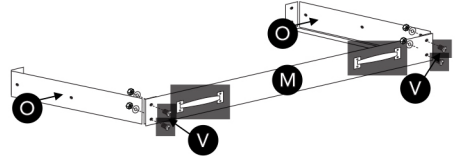

SCHRITT 14:

Senken Sie den Schubladenboden (P) in die Schubladenbaugruppe ab, so dass er auf den inneren Leisten aufliegt. Befestigen Sie die lange Schubladenrückwand (N) mit 4 kurzen Befestigungen (V) an der Baugruppe.

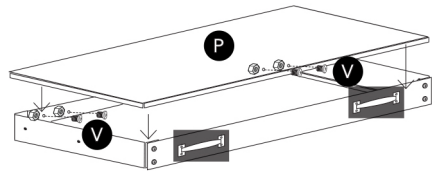

SCHRITT 15:

Befestigen Sie die 2 Schubladenschienen (U) an den kurzen Schubladenseiten (O) mit 4 kleinen Muttern/Schrauben (X) durch die verfügbaren Löcher wie abgebildet. Zur Sicherung festziehen.

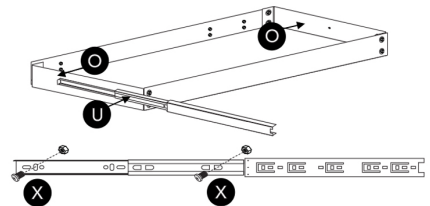

SCHRITT 16:

Halten Sie die Schublade innerhalb der Werkbankbaugruppe, fahren Sie die Schubladenschienen (U) aus und richten Sie sie mit den Befestigungslöchern in den Schubladenstützen (D, E) aus. Führen Sie 4 kleine Befestigungen (X) durch die Führungen und in die Halterungen ein. Zur Sicherung festziehen.

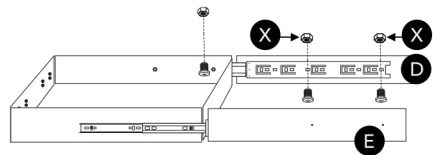

Setzen Sie die Schubladenstütze (S4) in die Mitte der Schublade ein und befestigen Sie sie mit (W).

BENUTZERGUIDE

MONTAGEANLEITUNG

SCHRITT 17:

Montieren Sie die Arbeitsfläche (S) und die untere Ablage (R), indem Sie sie vorsichtig in die entsprechenden Ebenen der Werkbank absenken (siehe Abbildung).

HINWEIS: Stecken Sie Haken (S2) in die Stecktafel (Q), damit Sie Werkzeuge einfach aufhängen können.

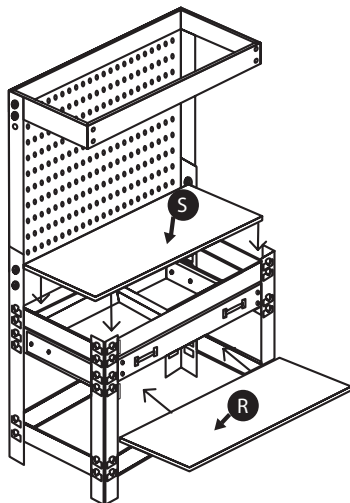

SCHRITT 18:

Montieren Sie die obere Ablage (T), indem Sie sie oben auf den Rahmen setzen und mit 2 kleinen Muttern/Bolzen (X) befestigen.

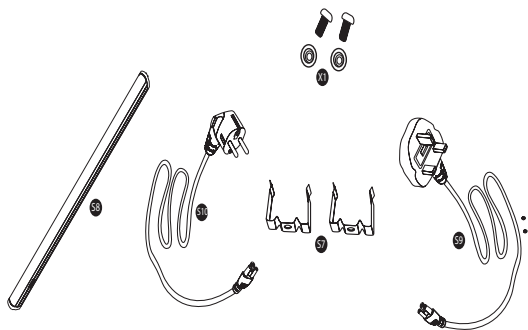
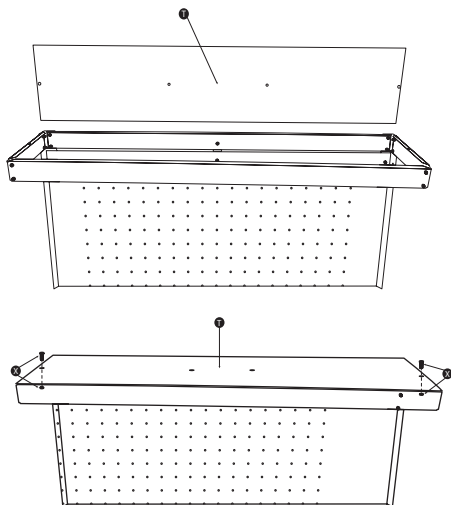

BENUTZERGUIDE

MONTAGEANLEITUNG

SCHRITT 19:

Befestigen Sie nun die Halterungen für die LED-Lampe (S7) mit den 2 X-kleinen Muttern/Bolzen (X1) an der Unterseite der oberen Ablage (T).

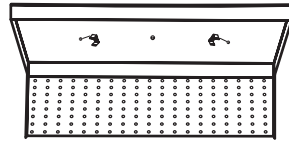
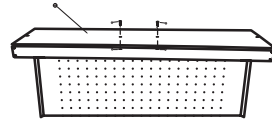

SCHRITT 20:

Stecken Sie dann entweder das UK- (S9) oder das EU-Kabel (S10) in die LED-Lampe (S8).

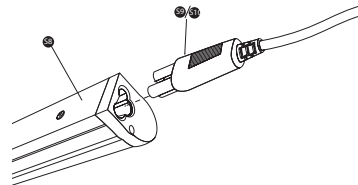

SCHRITT 21:

Schieben Sie die LED-Lampe (S8) in die Halterung (S7), die bereits unter der oberen Ablage angebracht ist, bis sie einrastet.

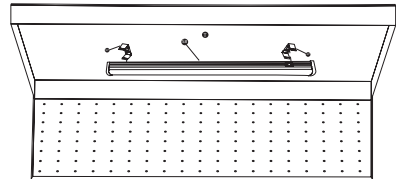

SCHRITT 22:

Führen Sie das überschüssige Kabel durch das nächste Loch auf der Stecktafel, so dass es Ihren Arbeitsbereich nicht beeinträchtigt.

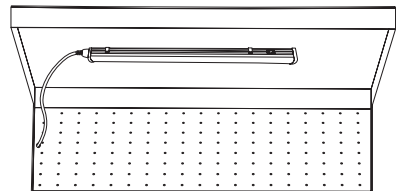

BENUTZERLEITFADEN

WARTUNG

- Behandeln Sie die MDF-Platten mit Lack oder Schimmelschutzmitteln, wenn Sie sie in einer feuchten Umgebung verwenden.
- Lassen Sie die LED-Lampe 10 Minuten lang abkühlen, bevor Sie sie aus der Halterung nehmen oder versuchen, sie zu reinigen. Reinigen Sie die LED-Lampe nur mit einem trockenen Tuch.

FEHLERBEHEBUNG

LÖSUNGSGUIDE

WAS MACHE ICH, WENN BEI MEINER BESTELLUNG TEILE FEHLEN?

Falls bei Ihrer Bestellung ein Teil zu fehlen scheint, wenden Sie sich bitte innerhalb von 7 Tagen nach Erhalt der Ware an unser freundliches und hilfsbereites Kundenservice-Team.

**FÜR ALLE ANDEREN FRAGEN WENDEN SIE SICH BITTE AN
UNSER KUNDENSERVICE-TEAM.**



ESPECIFICACIÓN

DESCRIPCIÓN DE PRODUCTO

Nuestro banco de trabajo con cajón y luz es la solución para sus necesidades de almacenamiento. Cuelgue todas sus herramientas imprescindibles en el tablero perforado con 40 ganchos incluidos, para que nunca esté nada fuera de su alcance. Con una lámpara LED para mantener su área de trabajo bien iluminada con un estante inferior grande, un práctico cajón y un estante superior, ¡amplio espacio de almacenamiento para mantener su espacio de trabajo impecable!

ESPECIFICACIONES DEL PRODUCTO

BANCO DE TRABAJO

MATERIAL: Acero con recubrimiento en polvo y MDF
DIMENSIONS: 150cm (A) x 120cm (L) x 60cm (F)

CAPACIDAD DE PESO

ESTANTE SUPERIOR: 30KG
AREA DE TRABAJO: 200KG
ESTANTE INFERIOR: 100KG
CAJÓN: 40KG

LUZ LED

POTENCIA DE ENTRADA: 9-10W
DIMENSIONES: 57.2cm (L) x 28cm (W) x 38cm (D)
FRECUENCIA: 50/60Hz

ESPECIFICACIÓN

CARACTERÍSTICAS DEL PRODUCTO

- A. Estante superior
- B. Luz LED
- C. Área de trabajo

- D. Cajón
- E. Tablero perforado
- F. Estante inferior



La responsabilidad de Monster Group UK Limited estará limitada únicamente al valor comercial del producto.

ESPECIFICACIÓN

CARACTERÍSTICAS DEL PRODUCTO

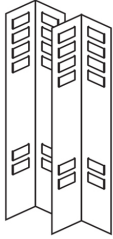

A Patas delanteras - x2



B Pata Trasera Izquierda - x1

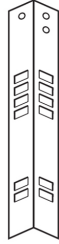

C Pata Trasera derecho - x1



D Soporte del Cajón Izquierdo - x1

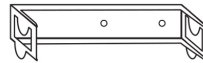

E Soporte del Cajón Derecho - x1

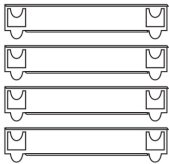

F Soportes cortos de encimera - x4

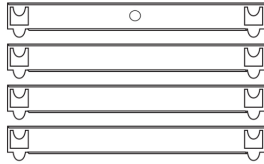

G Soportes largos de encimeras - x4



H Soporte Vertical izquierdo - x1



I Soporte Vertical Derecho - x1



J1 Soporte Trasero



K Soporte del estante superior izquierdo - x1



L Soporte de estante superior derecho x1



J2 Soporte Delantero

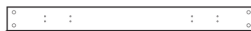

M Cajón delantero - x1



N Cajón trasero - x1



O Lados del cajón (cortos) - x2



P Base de Cajones - x1

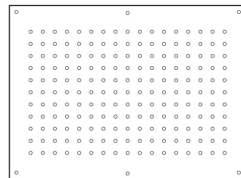

Q Tablero de clavijas - x1

La responsabilidad de Monster Group UK Limited estará limitada únicamente al valor comercial del producto.

ESPECIFICACIÓN

CARACTERÍSTICAS DEL PRODUCTO



R Repisa Inferior - x1



S Repisa - x1

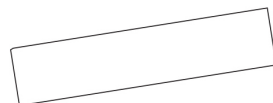

T Repisa Superior - x1



V Fijaciones cortes
- x30

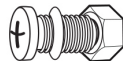

W Fijaciones largas
- x6



X Tuercas/Pernos (Pequeño)
- x16

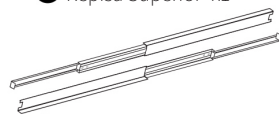

U Corredores de cajones - x2



Y Soporte de tablero
de clavijas - x1

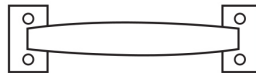

S1 Manijas de cajón - x2



S2 Clavijas - x40



S3 Tapas de pies - x4



S4 Soporte de Cajón - x1



S5 Soporte de Barras
- x2

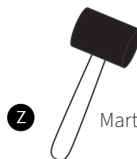

Z Martillo de Goma - x1

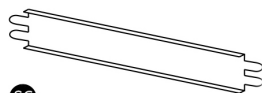

S6 Soporte de Barras
- x4

X1 – Tuercas / Pernos (X-Pequeña)

S9 - Cable para luz LED UK

S7 – Soportes luz LED

S10 – Cable para luz LED EU

S8 – Luz LED

CONSEJOS DE SEGURIDAD

PRÁCTICAS DE TRABAJO SEGURA

Lea las Prácticas para un trabajo seguro para garantizar la prevención de lesiones o daños al dispositivo.

- No utilice este producto para otro fin que no sea su uso previsto.
- Mantenga siempre el peso distribuido uniformemente para evitar daños en el banco de trabajo y para evitar que se caiga.
- No altere ni modifique este producto.
- Mantenga su área de trabajo despejada.
- Instale este producto sobre una superficie plana.
- Asegúrese de que no haya niños, mascotas o animales cerca cuando monte este banco de trabajo.
- No exceda la capacidad de carga que se muestra en las especificaciones del producto en la página 2.
- Inspeccione periódicamente el producto en busca de daños y signos de desgaste. Apriete cualquier componente que parezca estar suelto.
- Asegúrese de que las patas moldeadas estén colocadas correctamente para evitar posibles daños.
- Recomendamos dos personas para montar el producto.
- La luz LED solo es adecuada para una conexión a un suministro de 240V-50Hz.
- La luz LED solo está indicada para uso en interiores.
- Bajo ninguna circunstancia se debe cubrir la luz LED con ningún material.
- No conecte el cable de la luz LED a la red eléctrica hasta que se haya conectado a la luz LED.
- No instale la luz LED cerca de una fuente de agua. No es adecuada para una ubicación de baño.
- Si el cable de alimentación se daña de algún modo, no intente utilizarlo. Póngase en contacto con nuestro equipo de atención al cliente para pedir un reemplazo.
- Deje que la luz LED se enfríe durante 10 minutos antes de retirarla de los soportes o intentar limpiarla.

GUÍA DEL USUARIO

INSTRUCCIONES DE ARMADO

Para dejar espacio para que las pestañas encajen de forma segura, se recomienda que abra suavemente las pestañas con un destornillador de cabeza plana adecuado (no suministrado). Una vez que se han insertado las pestañas, cierre suavemente con un mazo de goma adecuado para asegurar.

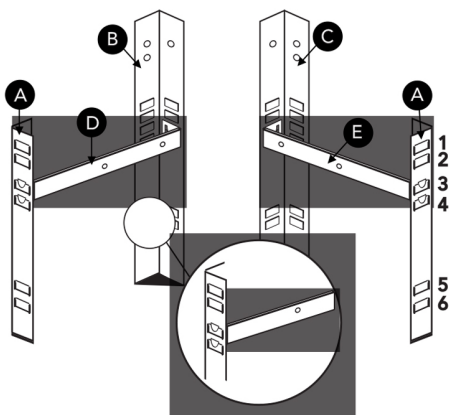
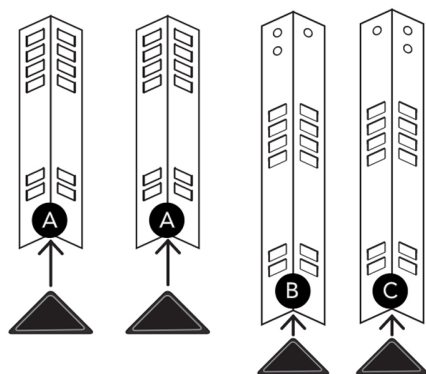

PASO 1:

Sujete las 4 tapas de pie (S3) en los extremos de las patas (A, B, C) como se ilustra.

PASO 2:

Coloque los soportes de cajón (D, E) entre las patas delanteras y traseras (A, B, C) y fijela como se ilustra.

Los soportes para cajón deben colocarse entre la tercera y cuarta ranura y mirar hacia atrás.

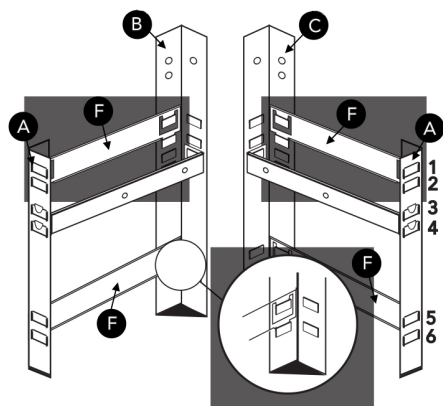

PASO 3:

Coloque los 4 soportes de repisa (F) en las patas delanteras y traseras (A, B, C) como se ilustra.

Los soportes de repisa deben colocarse entre las ranuras 1ª / 2ª y 5ª / 6ª.

GUÍA DEL USUARIO

INSTRUCCIONES DE ARMADO

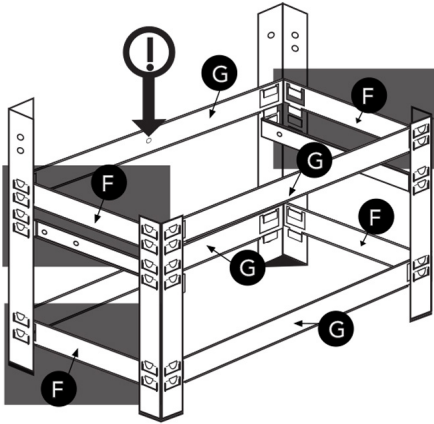

PASO 4:

Coloque los 4 soportes largos de la repisa (G) en las patas delanteras y traseras (A, B, C) en las ranuras primera / segunda y quinta / sexta.

El soporte largo de la repisa con el orificio central debe colocarse entre las ranuras 1ª / 2ª en las patas traseras (B, C).

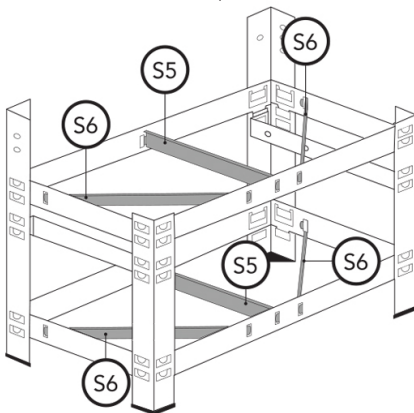

PASO 4.1:

Ajustar los soportes (S5 y S6) al marco.

PASO 5:

Doble las pestañas en cada extremo de las barras de soporte (S5) en un ángulo de 90°. Ubique las ranuras en la parte superior e inferior y colóquelas en su lugar entre las vigas laterales delanteras y traseras (G).

Doble las pestañas sobre sí mismas (como se muestra a continuación) para unir.

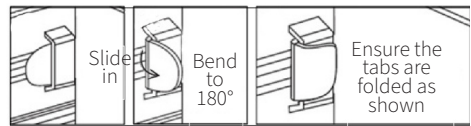

Coloque los soportes verticales superiores izquierdo y derecho (H, I) en los lados de las patas traseras (B, C).

Asegure con 4 fijaciones cortas (V).

Apriete con una llave adecuada para asegurar. Asegure las barras de soporte (S5) en su lugar con (W).

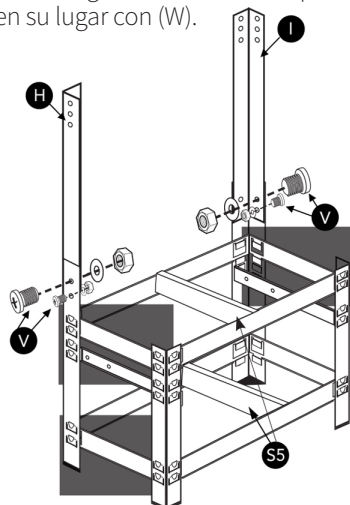

GUÍA DEL USUARIO

INSTRUCCIONES DE ARMADO

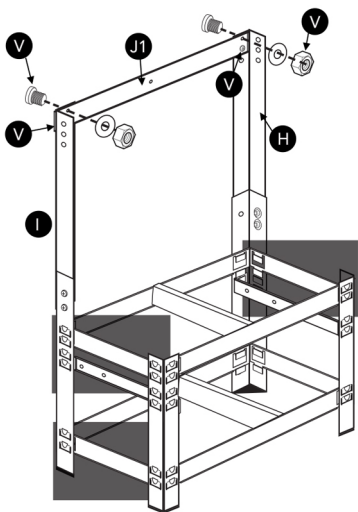

PASO 6:

Fije el soporte posterior (J1) en la parte superior 2 agujeros de los soportes verticales (H, I). Asegure con 4 fijaciones cortas (V). Apriete para asegurar.

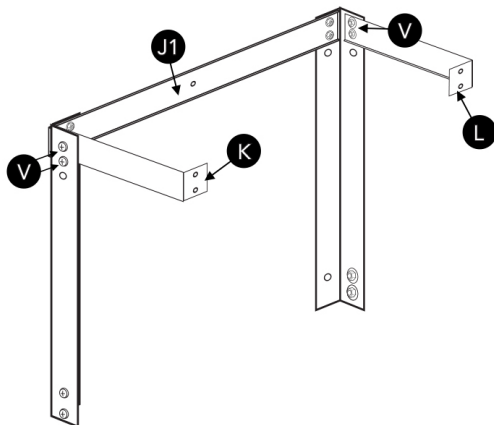

PASO 7:

Fije el borde más largo de los soportes de estante superior cortos (K, L) a los 2 orificios superiores de los soportes verticales (H, I) con 4 fijaciones cortas (V) como se ilustra. Apriete para asegurar.

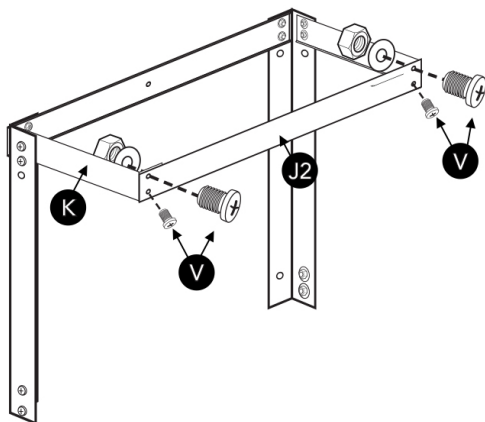

PASO 8:

Fije el soporte frontal (J2) al frente de los soportes de estante superior cortos (K, L) utilizando 4 fijaciones cortas (V) como se ilustra. Apriete para asegurar.

GUÍA DEL USUARIO

INSTRUCCIONES DE ARMADO

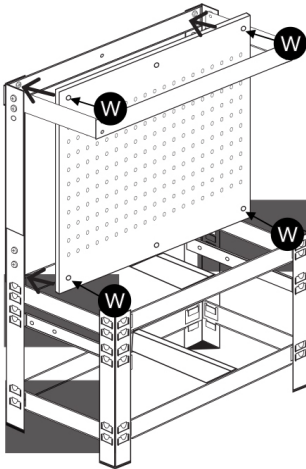

PASO 9:

Fije el tablero de clavijas (Q) con 4 fijaciones largas (W).
Apriete para asegurar.

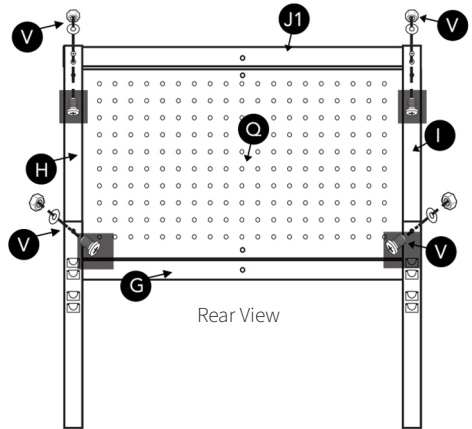

PASO 10:

Desde la parte posterior, inserte 4 fijaciones cortas (V) en los agujeros vacíos en los soportes verticales (H, I). Apriete para asegurar.

Desde la parte posterior, inserte 4 fijaciones

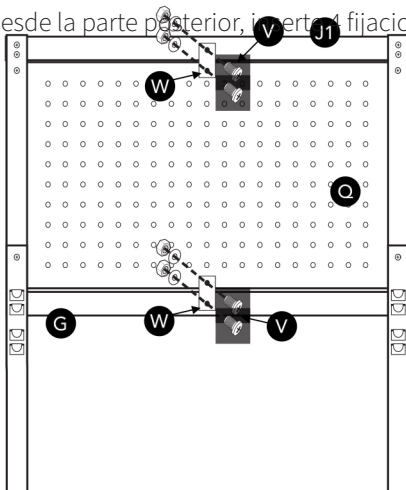

PASO 11:

Usando 2 fijaciones cortas (V), fije los soportes de tablero (Y) en la parte posterior del conjunto a través de los agujeros vacíos en los soportes largos (G, J1).

Inserte 2 fijaciones largas (W) en los agujeros vacíos en los soportes del tablero (Y) y en el tablero (Q). Apriete todo para asegurar.

GUÍA DEL USUARIO

INSTRUCCIONES DE ARMADO

PASO 12:

Fije las 2 manijas del cajón (S1) al frente del cajón (M) insertando 8 tuercas / pernos pequeños (X) desde el exterior hacia la repisa. Apriete para asegurar.

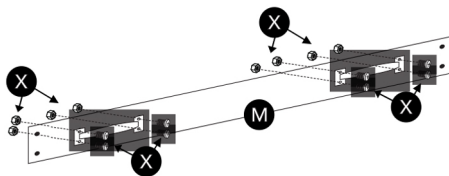

PASO 13:

Fije los lados cortos del cajón (O) al frente del cajón (M) con 4 fijaciones cortas (V). Apriete para asegurar.

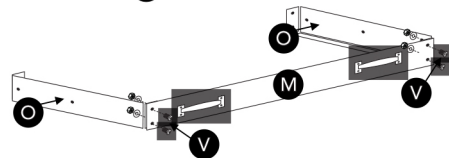

PASO 14:

Baje la base del cajón (P) en el ensamblaje del cajón para descansar sobre las repisas internas. Fije la parte posterior larga del cajón (N) al ensamblaje usando 4 fijaciones cortas (V).

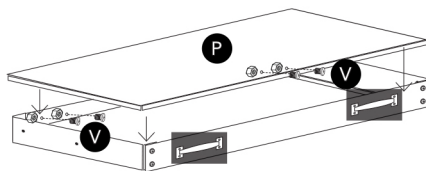

PASO 15:

Fije los 2 corretores del cajón (U) a los lados cortos del cajón (O) usando 4 tuercas / pernos pequeños (X) a través de los agujeros disponibles como se ilustra. Apriete para asegurar.

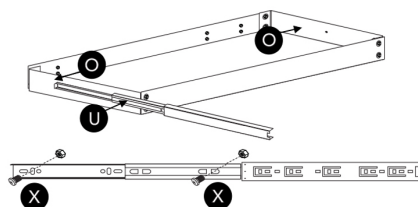

PASO 16:

Sosteniendo el cajón dentro del ensamblaje de la mesa de trabajo, extienda y alinee los corretores del cajón (U) con los agujeros de fijación en los soportes del cajón (D, E). Inserte 4 pequeñas fijaciones (X) a través de los corretores y en los soportes. Apriete para asegurar.

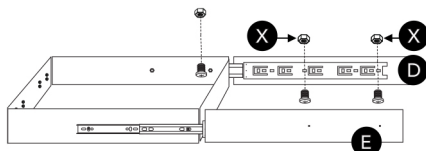

Inserte el soporte del cajón (S4) en el centro del cajón y fíjelo en su lugar con (W).

GUÍA DEL USUARIO

INSTRUCCIONES DE ARMADO

PASO 17:

Coloque la encimera (S) y el estante inferior (R) bajándolos suavemente a los niveles apropiados en el banco de trabajo como se muestra en la ilustración.

NOTA: Inserte las clavijas (S2) en el tablero de clavijas (Q) para colgar las herramientas.

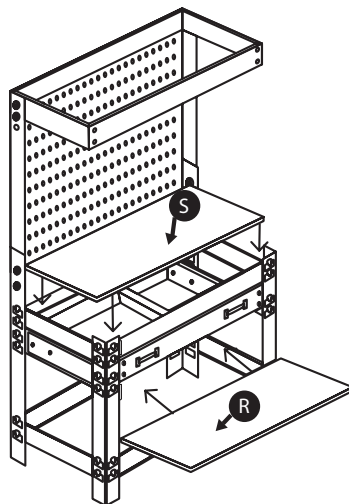

PASO 18:

Coloque el estante superior (T) colocándolo encima del marco y asegurándolo en su lugar con 2 tuercas/pernos pequeños (X).

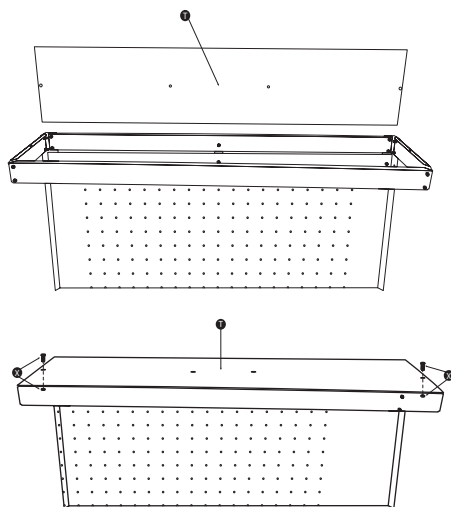
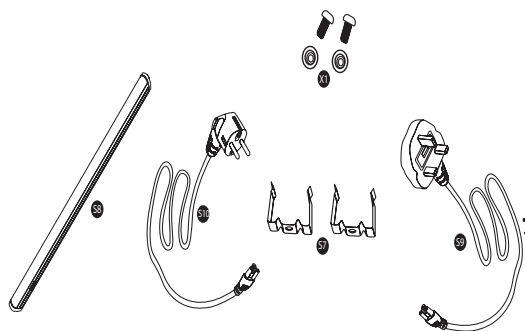

GUÍA DEL USUARIO

INSTRUCCIONES DE ENSAMBLAJE

PASO 19:

Ahora coloque los soportes de la luz LED (S7) en la parte inferior del estante superior (T) usando los 2 pernos/tuercas extrapequeños (X1).

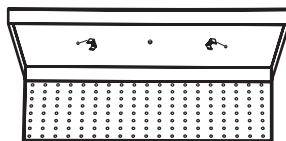
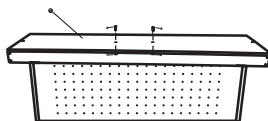

PASO 20:

Luego inserte el cable UK (S9) o de la UE (S10) en la luz LED (S8).

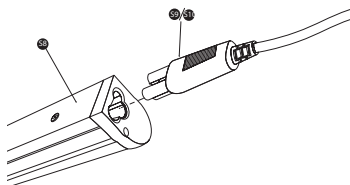

PASO 21:

Inserte la luz LED (S8) en los soportes (S7) ya colocados debajo del estante superior hasta que encajen en su lugar.

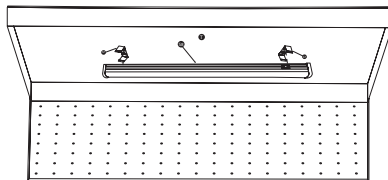

PASO 22:

Pase el cable sobrante por el orificio más cercano en el tablero perforado para que no interfiera en su espacio de trabajo.

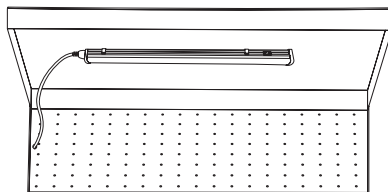

GUÍA DEL USUARIO

MANTENIMIENTO

- Eventualmente trate los tableros de MDF con barniz o productos para la prevención de moho si se usan en un ambiente húmedo.
- Deje que la luz LED se enfríe durante 10 minutos antes de retirarla de los soportes o intentar limpiarla. Limpie la luz LED solo con un paño seco.

SOLUCIÓN DE PROBLEMAS

GUÍA DE RESOLUCIÓN

¿QUÉ HAGO SI HAY PIEZAS FALTANTES DE MI PEDIDO?

Si parece que falta alguna pieza en su pedido, comuníquese con nuestro Equipo de Atención al Cliente amable y servicial dentro de los 7 días posteriores a la recepción.

PARA TODAS LAS OTRAS CUESTIONES, CONTACTE A NUESTRO EQUIPO DE APOYO AL CLIENTE.

SPECIFICHE

DESCRIZIONE DEL PRODOTTO

Il nostro banco da lavoro, dotato di cassetto e lampada, è la soluzione ideale per organizzare e riporre tutti gli utensili. Gli utensili indispensabili possono essere appesi al pannello fornito di 40 ganci, in modo da essere sempre a portata di mano.

Questo banco da lavoro, dotato di una lampada a LED che illumina l'area di lavoro, di un ampio ripiano inferiore, di un pratico cassetto e di un ripiano superiore, consente di mantenere lo spazio di lavoro pulito e ordinato!

SPECIFICHE DEL PRODOTTO

BANCO DA LAVORO

MATERIALE:	Acciaio verniciato a polvere e MDF
MISURE:	150cm (Lunghezza) x 120cm (Larghezza) x 60cm (Profondità)

CAPACITÀ DI CARICO

RIPIANO SUPERIORE:	30KG
SUPERFICIE DI LAVORO:	200KG
RIPIANO INFERIORE:	100KG
CASSETTO:	40KG

LAMPADA A LED

POTENZA IN INGRESSO:	9-10W
MISURE:	57,2cm (Lunghezza) x 28cm (Larghezza) x 38cm (Profondità)
FREQUENZA DI RETE:	50/60Hz

SPECIFICHE

CARATTERISTICHE DEL PRODOTTO

- A. Ripiano superiore
- B. Lampada a LED
- C. Superficie di lavoro

- D. Cassetto
- E. Pannello forato
- F. Ripiano inferiore



La responsabilità di Monster Group UK Limited sarà limitata al solo valore commerciale del prodotto.

SPECIFICHE

ELENCO DELLE PARTI

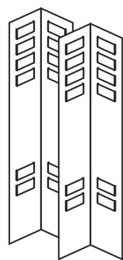

A Gambe Anteriori - x2



B Gamba Sinistra Posteriore - x1



C Gamba Destra Posteriore - x1

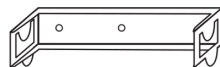

D Supporto Sinistro per il Cassetto - x1

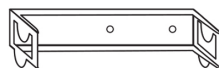

E Supporto Destro per il Cassetto - x1

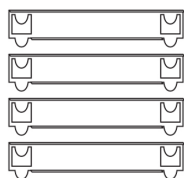

F Supporti Corti per il Piano di Lavoro - x4

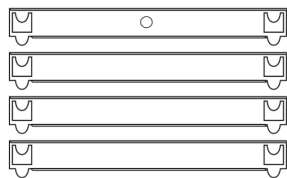

G Supporti Lung- hi per il Piano di Lavoro - x4



H Supporto Verticale Sinistro - x1



I Supporto Verticale Destro - x1



J1 Supporto Posteriore - x1

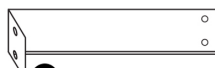

K Supporto Sinistro per il Ripiano Superiore - x1

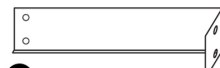

L Supporto Destro per il Ripiano Superiore - x1



J2 Supporto Frontale



M Parte Frontale del Cassetto - x1



N Parte Posteriore del Cassetto - x1

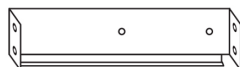

O Lati del Cassetto (Corti) - x2

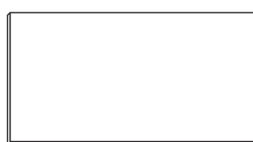
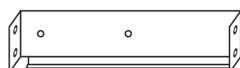

P Base del Cassetto - x1

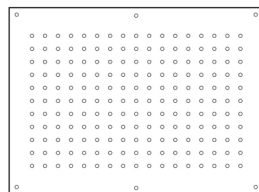

Q Pannello Forato - x1

La responsabilità di Monster Group UK Limited sarà limitata al solo valore commerciale del prodotto.

SPECIFICHE

ELENCO DELLE PARTI



R Ripiano Inferiore - x1



S Piano di Lavoro - x1

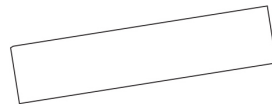

T Ripiano Superiore - x1



V Fissaggi
Corti - x30

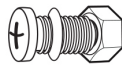

W Fissaggi
Lunghi - x6

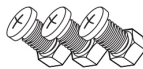

X Dadi/Bulloni (Piccoli) - x16

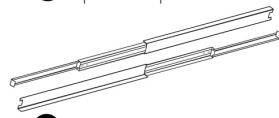

U Binari per il Cassetto - x2



Y Supporti del
Pannello Forato - x1

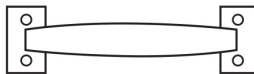

S1 Maniglie dei Cassetti - x2



S2 Pioli - x40



S3 Coperture per i Piedi - x4



S4 Supporto per il Cassetto - x1



S5 Barre di Supporto - x2

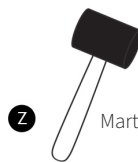

Z Martello di Gomma - x1

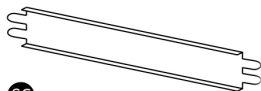

S6 Barre di Supporto - x4

X1 - Dadi/bulloni (Piccolo-X)

S9 - Cavo UK per la lampada a LED

S7 - Staffe per la lampada a LED

S10 - Cavo UE per la lampada a LED

S8 - Lampada a LED

CONSIGLI PER LA SICUREZZA

PRATICHE DI LAVORO SICURE

Leggere attentamente le corrette procedure operative, per evitare di causare incidenti e per non danneggiare il prodotto.

- Il prodotto non deve essere utilizzato per scopi diversi da quelli specificati.
- Per evitare di danneggiare il banco da lavoro e impedirne il ribaltamento, il peso deve essere sempre distribuito in modo uniforme.
- Non apportare alcuna modifica al prodotto.
- Tenere l'area di installazione in ordine e libera da intralci.
- Utilizzare il prodotto su una superficie piana.
- Durante il montaggio del banco da lavoro, accertarsi che non vi siano bambini o animali domestici nelle vicinanze.
- Non superare la capacità di carico indicata nelle specifiche del prodotto a pagina 2.
- Ispezionare regolarmente il prodotto per individuare eventuali danni e segni di usura. Serrare tutti i componenti eventualmente allentati.
- Per evitare il rischio di eventuali lesioni, accertarsi che i piedini sagomati siano fissati correttamente.
- Per l'assemblaggio del prodotto si consiglia l'intervento di due persone.
- La lampada a LED deve essere collegata esclusivamente a una presa di alimentazione da 240V-50Hz.
- La lampada a LED è destinata esclusivamente all'uso in ambienti interni.
- Non è consentito coprire in alcun caso la lampada a LED con un qualsiasi tipo di materiale.
- Prima di collegare il cavo della lampada a LED alla rete elettrica, è indispensabile che questo sia stato prima collegato alla lampada.
- Non installare la lampada a LED in prossimità di fonti idriche. Non è adatta alla collocazione in ambienti che ospitano i servizi igienici.
- Non utilizzare in nessun caso il cavo di alimentazione nel caso in cui dovesse danneggiarsi. Contattare il nostro team di assistenza clienti per la sostituzione.
- Prima di rimuovere la lampada a LED dalle staffe o prima di pulirla, lasciarla raffreddare per 10 minuti.

GUIDA UTENTE

ISTRUZIONI DI MONTAGGIO

Al fine di fare in modo che vi sia spazio per le linguette così da poterle inserire in modo sicuro, si consiglia di aprire le linguette facendo delicatamente leva con un cacciavite a testa piatta adatto (non fornito). Dopo aver inserito le linguette, battere delicatamente con un martello di gomma adatto per chiuderle.

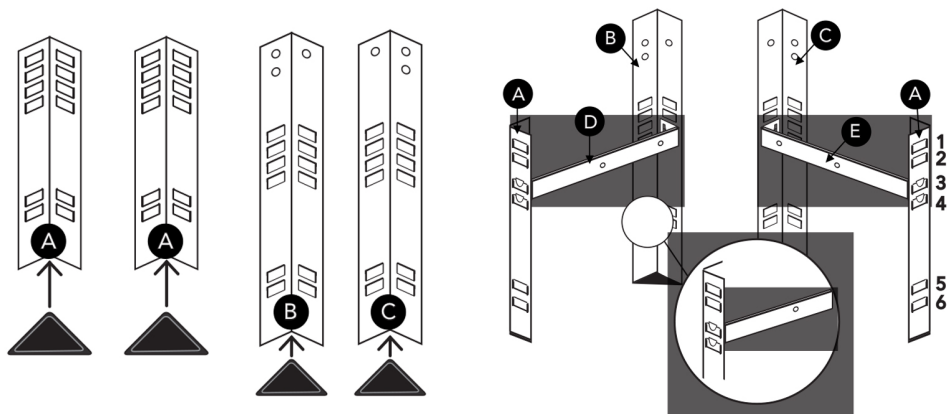

PASSO 1:

Agganciare i 4 Piedini (S3) alle estremità delle Gambe (A, B, C) come illustrato.

PASSO 2:

Montare i Supporti dei Cassetti (D, E) tra le Gambe Anteriore e Posteriore (A, B, C) e fissarli come illustrato.

I Supporti del Cassetto devono essere montati tra la 3a e la 4a fessura e rivolti verso l'esterno.

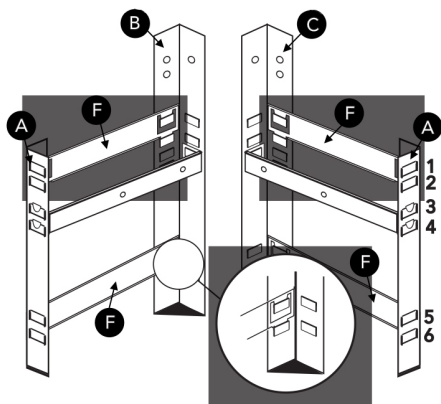

PASSO 3:

Montare i 4 Supporti del Piano di Lavoro (F) sulle Gambe Anteriore e Posteriore (A, B, C) come illustrato.

I supporti corti per il piano di lavoro devono essere posizionati tra la 1a/2a e la 5a/6a fessura.

GUIDA UTENTE

ISTRUZIONI DI MONTAGGIO

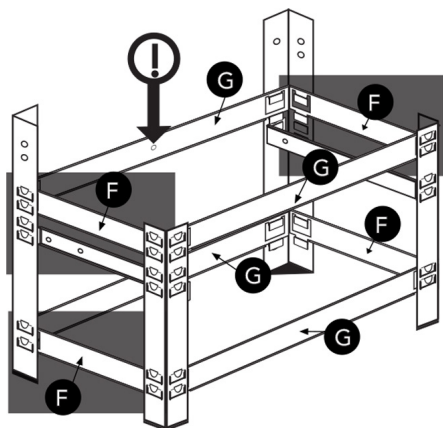

PASSO 4:

Montare i 4 Supporti Lunghi per il Piano di Lavoro (G) sulle gambe anteriore e posteriore (A, B, C) nelle fessure 1a/2a e 5a/6a.

Il Supporto Lungo per il Piano di Lavoro con il foro centrale deve essere posizionato tra la 1a/2a fessura sulle Gambe Posteriori (B, C).

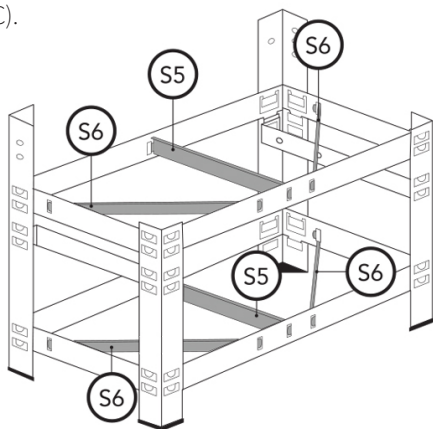

PASSO 4.1:

Inserisci i supporti (S5 & S6) nel telaio.

PASSO 5:

Piegare le linguette su ciascuna estremità delle Barre di Supporto (S5) con un angolo di 90°. Individuare le fessure sulla parte superiore e inferiore e posizionarle tra le Barre Anteriore e Posteriore (G).

Piegare di nuovo le linguette su se stesse (come mostrato sotto) per fissarle.

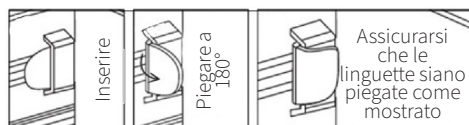

Montare i Supporti Verticali Superiori Sinistro e Destro (H, I) sui lati delle Gambe Posteriori (B, C).

Fissare utilizzando i 4 Fissaggi Corti (V).

Stringere con una chiave adatta per fissare il tutto. Fissare le barre di supporto (S5) in posizione utilizzando (W).

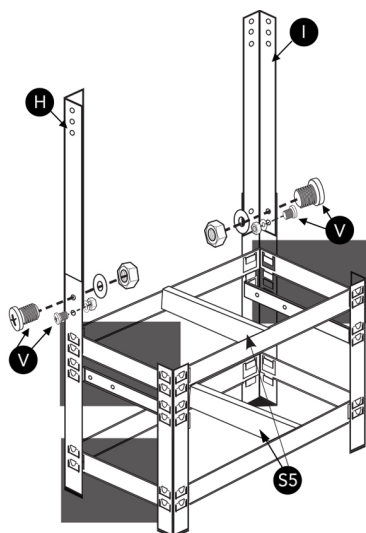

GUIDA UTENTE

ISTRUZIONI DI MONTAGGIO

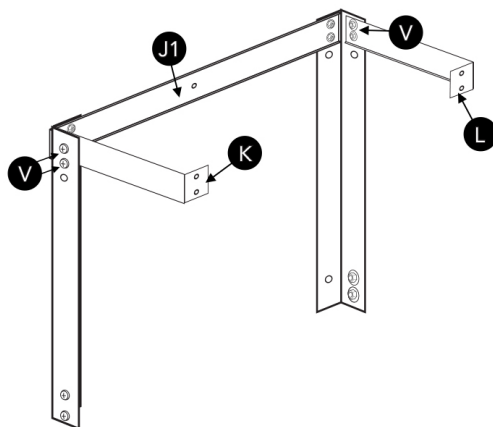
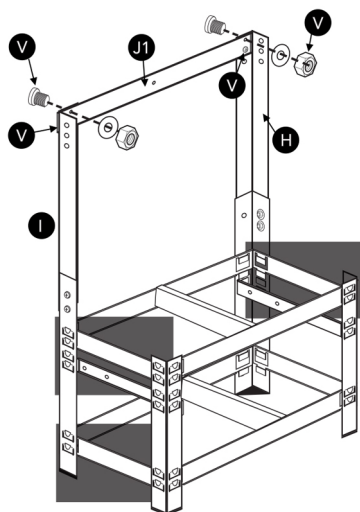

PASSO 6:

Fissare il Supporto Posteriore (J1) sui 2 fori in alto dei Supporti Verticali (H, I). Fissare il tutto con 4 Fissaggi Corti (V). Stringere per fissare.

PASSO 7:

Fissare il bordo più lungo dei Supporti Corti del Ripiano Superiore (K, L) ai 2 fori superiori dei Supporti Verticali (H, I) utilizzando 4 Fissaggi Corti (V) come illustrato. Stringere per fissare.

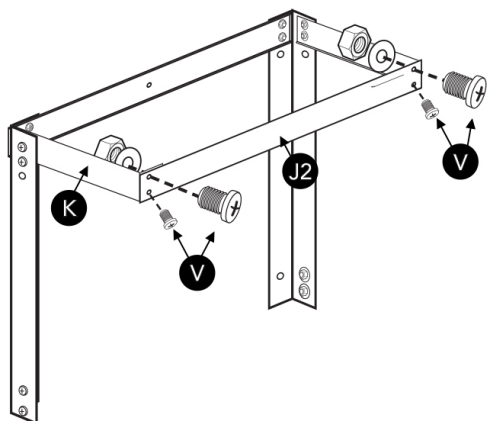

PASSO 8:

Fissare il Supporto Anteriore (J2) alla parte anteriore dei Supporti Corti del Ripiano Superiore (K, L) usando 4 Fissaggi Corti (V) come illustrato. Stringere per fissare.

GUIDA UTENTE

ISTRUZIONI DI MONTAGGIO

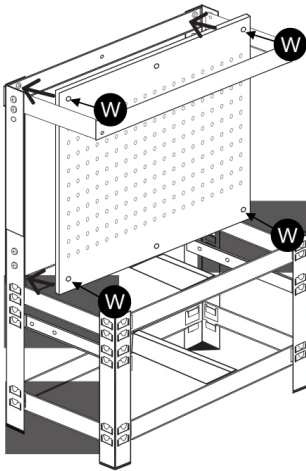

PASSO 9:

Fissare il Pannello Forato (Q) con 4 Fissaggi Lunghi (W). Stringere per fissare.

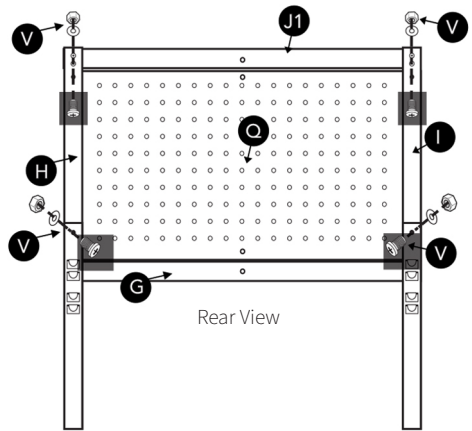

PASSO 10:

Dal retro, inserire 4 fissaggi corti (V) nei fori vuoti dei Supporti Verticali (H, I). Stringere per fissare.

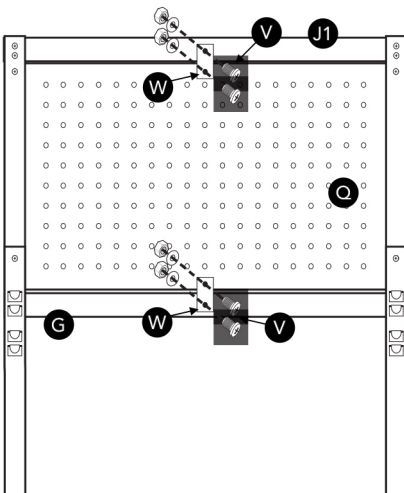

PASSO 11:

Utilizzando 2 Fissaggi Corti (V), attaccare i Supporti del Pannello Forato (Y) alla parte posteriore della parte assemblata utilizzando i fori vuoti sui Supporti Lunghi (G, J1).

Inserire 2 Fissaggi Lunghi (W) nei fori vuoti sui Supporti del Pannello Forato (Y) e nel Pannello Forato (Q). Stringere il tutto per fissare.

GUIDA UTENTE

ISTRUZIONI DI MONTAGGIO

PASSO 12:

Fissare le 2 Maniglie dei Cassetti (S1) sulla parte Frontale del Cassetto (M) inserendo 8 Dadi/Bulloni Piccoli (X) dall'esterno verso la sporgenza. Stringere per fissare.

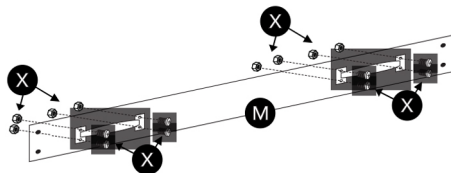

PASSO 13:

Fissare i Lati Corti del Cassetto (O) sul lato Frontale del Cassetto (M) utilizzando 4 Fissaggi Corti (V). Stringere per fissare.

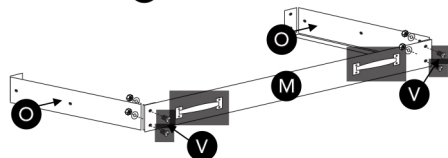

PASSO 14:

Posizionare la Base del Cassetto (P) nell'assemblaggio del cassetto per assestare le sporgenze interne. Fissare il Retro Lungo del Cassetto (N) all'assemblaggio utilizzando 4 Fissaggi Corti (V).

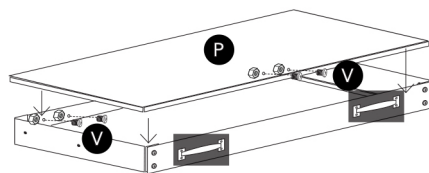

PASSO 15:

Fissare i 2 binari del cassetto (U) sui Lati Corti del Cassetto (O) utilizzando 4 Dadi/Bulloni Piccoli (X) attraverso i fori disponibili, come illustrato. Stringere per fissare.

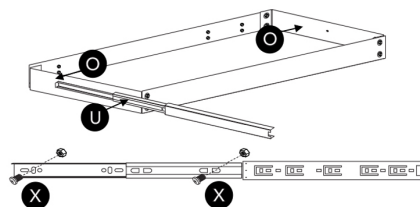

PASSO 16:

Tenendo il cassetto all'interno dell'assemblaggio del Banco di Lavoro, estendere e allineare i Binari del Cassetto (U) con i fori di fissaggio nei Supporti del Cassetto (D, E). Inserire 4 Fissaggi Piccoli (X) attraverso i Binari e nei Supporti. Stringere per fissare.

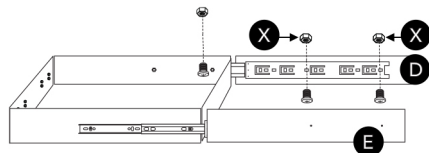

Inserire il Supporto del Cassetto (S4) al centro del cassetto e fissarlo in posizione utilizzando (W).

GUIDA UTENTE

ISTRUZIONI DI MONTAGGIO

PASSO 17:

Montare il piano di lavoro (S) e il ripiano inferiore (R) posizionandoli con cautela in corrispondenza degli appositi livelli del banco da lavoro, come illustrato.

FACOLTATIVO: Per una maggiore praticità, inserire i ganci (S2) nel pannello forato (Q) in modo da potervi appendere gli attrezzi.

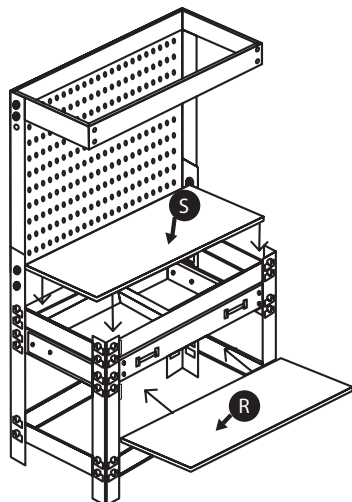

PASSO 18:

Montare il ripiano superiore (T) posizionandolo nella parte superiore del telaio, e fissarlo in posizione con 2 dadi / bulloni piccoli (X).

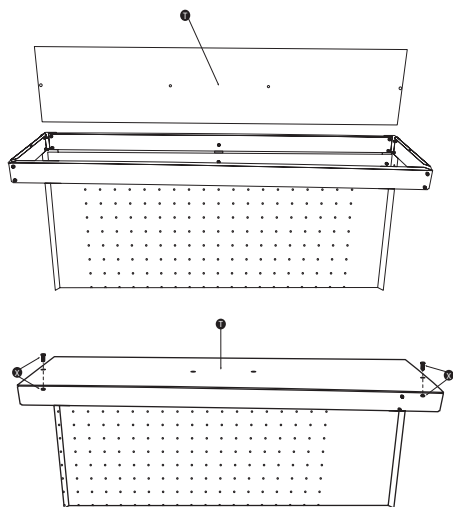
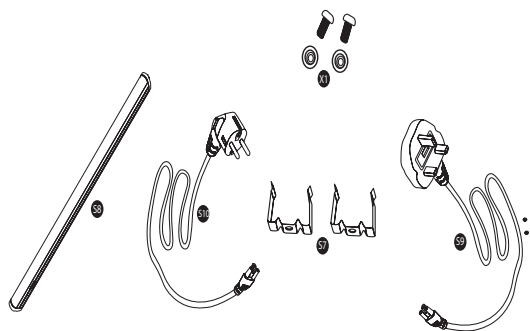

GUIDA UTENTE

ISTRUZIONI DI MONTAGGIO

PASSO 19:

Montare le staffe per la lampada a LED (S7) sul lato inferiore del ripiano superiore (T) utilizzando i 2 dadi / bulloni piccoli (X1).

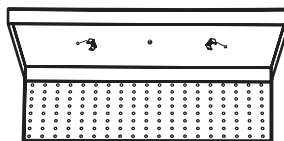
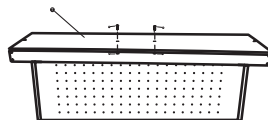

PASSO 20:

Successivamente, collegare il cavo UK (S9) o UE (S10) alla lampada a LED (S8).

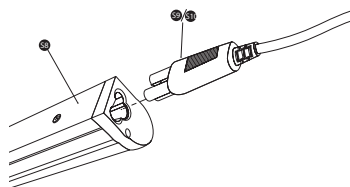

PASSO 21:

Inserire la lampada a LED (S8) nelle staffe (S7) precedentemente installate sotto il ripiano superiore, fino a che non si incastrino in posizione.

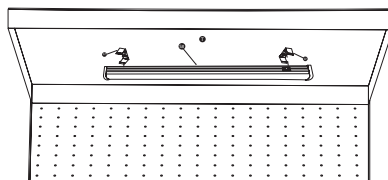

PASSO 22:

Infilare il cavo in eccesso nel foro più vicino al pannello forato, in modo che non intralci lo spazio di lavoro.

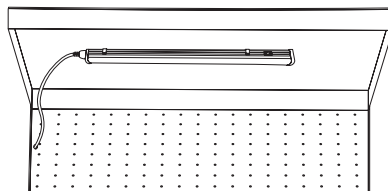

GUÍA DEL USUARIO

MANTENIMIENTO

- Se il prodotto viene utilizzato in un ambiente umido, trattare i pannelli in MDF con vernice o prodotti antimuffa.
- Prima di rimuovere la lampada a LED dalle staffe o prima di pulirla, lasciarla raffreddare per 10 minuti. Per pulire la lampada a LED utilizzare solo un panno asciutto.

RISOLUZIONE DEI PROBLEMI

GUIDA ALLA RISOLUZIONE DEI PROBLEMI

COSA DEVO FARE SE NEL MIO ORDINE CI SONO DELLE PARTI MANCANTI?

Se sembra che all'interno del tuo ordine manchino delle parti, contatta il nostro gentile e disponibile team di assistenza clienti entro 7 giorni dalla ricezione del tuo ordine.

PER QUALUNQUE ALTRO PROBLEMA, CONTATTA IL NOSTRO TEAM DI ASSISTENZA CLIENTI.



SPECIFICATIES

PRODUCT OMSCHRIJVING

Onze werkbank met lade en verlichting is de perfecte oplossing voor je opslagbehoeften. Hang al je onmisbare gereedschap aan het ophangbord met 40 haken, zodat ze nooit buiten bereik zijn.

Met een LED-lamp die je stevige werkruimte goed verlicht en een grote onderste plank, handige lade en bovenste plank houdt de ruime opbergruimte van deze werkbank je werkruimte spik en span!

PRODUCT SPECIFICATIES

WERKBANK

MATERIAAL: Gepoedercoat staal en MDF
AFMETINGEN: 150cm (L) x 120cm (B) x 60cm (D)

DRAAGVERMOGEN

BOVENSTE PLANK: 30KG
WERKBANK: 200KG
ONDERSTE PLANK: 100KG
LADE: 40KG

LED VERLICHTING

INPUT VERMOGEN: 9-10W
AFMETINGEN: 57.2cm (L) x 28cm (W) x 38cm (D)
FREQUENTIE: 50/60Hz

SPECIFICATIES

PRODUCT EIGENSCHAPPEN

- A. Bovenste plank
- B. LED verlichting
- C. Werkbank
- D. Lade
- E. Ophangbord
- F. Onderste plank



De aansprakelijkheid van Monster Group UK Limited is beperkt tot de commerciële waarde van het product.

SPECIFICATIES

ONDERDELEN LIJST

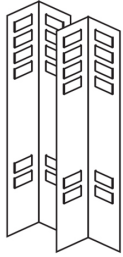

A Poten voorkant
- x2



B Poort links achter - x1



C Poort rechts achter - x1



D Linker lade steun - x1

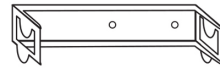

E Rechter lade steun - x1

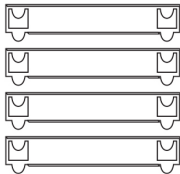

F Korte werkbank
Steunen - x4

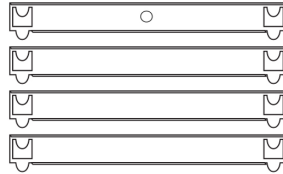

G Lange werkbank
Steunen - x4



H Linker
Verticale
Steun - x1



I Rechter Verticale
Steun - x1

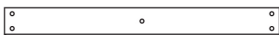

J1 Steun Achterkant



K Bovenste plank
Steun links - x1



L Bovenste plank
Steun rechts - x1



J2 Steun voor



M Lade voorkant - x1



N Lade achterkant - x1

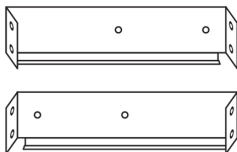

O Lade zijkant kor - x2



P Lade Bodem - x1

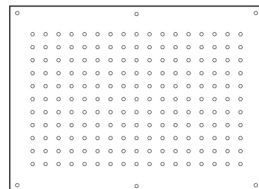

Q Ophangbord - x1

De aansprakelijkheid van Monster Group UK Limited is beperkt tot de commerciële waarde van het product.

SPECIFICATIES

ONDERDELEN LIJST

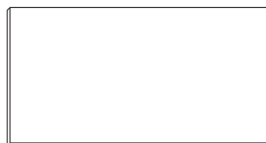

R Onderste plank - x1

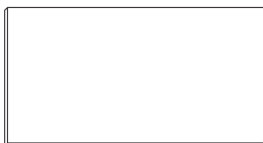

S Werkbank - x1

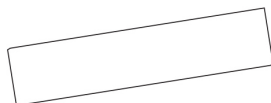

T Bovenste plank - x1



V Korte schroef - x30



W Lange schroef - x6



X Moeren/bouten (Klein) - x16

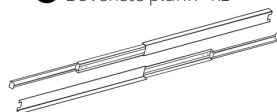

U Lade geleiders - x2



Y Ophangbord
Steun - x1



S1 Handgreep lade - x2



S2 Pinnen - x40



S3 Dopvoeten - x4

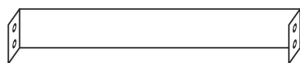

S4 Lade steun - x1

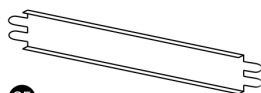

S5 Steunbalken - x2

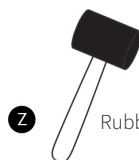

Z Rubber Hamer - x1

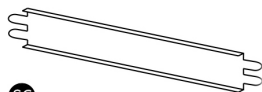

S6 Steunbalken - x4

X1 – Moeren/Bouten (X-Small)

S9 – UK LED verlichting kabel

S7 – Beugels voor LED verlichting

S10 – EU LED verlichting kabel

S8 – LED verlichting

VEILIGHEIDS ADVIES

VEILIG WERKEN

Lees a.u.b. Het advies voor veilig gebruik door om letsel of schade aan het apparaat te voorkomen.

- Gebruik dit product niet voor iets anders dan waarvoor het bedoeld is.
- Houd het gewicht altijd gelijkmatig verdeeld om schade aan de werkbank te voorkomen en om te voorkomen dat de werkbank omvalt.
- Breng op geen enkele manier wijzigingen op dit product aan.
- Houd je werkplek vrij van rommel.
- Gebruik dit product op een vlakke ondergrond.
- Zorg ervoor dat er geen kinderen, huisdieren of dieren in de buurt zijn bij het installeren van deze werkbank.
- Overschrijd het draagvermogen dat in de productspecificaties op pagina 2 weergegeven wordt niet.
- Inspecteer het product regelmatig op beschadigingen en gebruikssporen. Draai alle onderdelen die los lijken te zitten vast.
- Zorg ervoor dat de gegoten pootjes correct zijn bevestigd om mogelijk letsel te voorkomen.
- We raden aan dat het product door twee personen gemonteerd wordt.
- De ledlamp is alleen geschikt voor aansluiting op een 240V-50Hz voeding.
- De ledlamp is alleen voor gebruik binnenshuis.
- De ledlamp mag in geen geval met enig materiaal worden bedekt.
- Steek de LED-lichtkabel niet in het stopcontact voordat deze is aangesloten op de LED-lamp.
- Installeer de Ledlamp niet op een plaats in de buurt van een waterbron. Het is niet geschikt voor een badkamer.
- Probeer het product niet te gebruiken wanneer het netsnoer op enigerlei wijze beschadigd is. Neem contact op met ons klantenserviceteam over een vervanging.
- Laat de ledlamp 10 minuten afkoelen voordat je hem uit de beugels haalt of probeert schoon te maken.

HANDLEIDING

MONTAGE-INSTRUCTIES

Om ervoor te zorgen dat de lipjes goed passen, is het raadzaam de lipjes voorzichtig open te wrikken met een geschikte platte schroevendraaier (niet meegeleverd). Zodra de lipjes zijn geplaatst, tikt u deze voorzichtig dicht met een geschikte rubberen hamer om het vast te zetten.

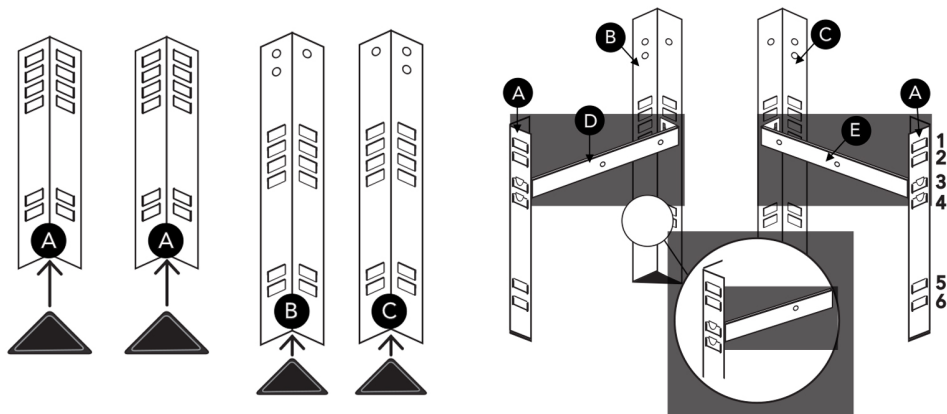

STAP 1:

Klem de 4 dopvoeten (S3) op de uiteinden van de poten (A, B, C) zoals afgebeeld.

STAP 2:

Monteer de ladesteunen (D, E) tussen de voor- en achterpoten (A, B, C) en zet vast zoals afgebeeld.

De ladesteunen moeten tussen de 3e en 4e sleuf worden geplaatst en naar buiten wijzen.

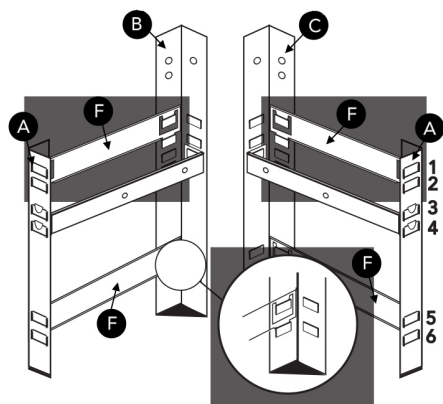

STAP 3:

Bevestig de 4 werkbladsteunen (F) aan de voor- en achterpoten (A, B, C) zoals afgebeeld.

De korte werkbladsteunen moeten tussen de 1e / 2e en 5e / 6e sleuf worden geplaatst.

HANDLEIDING

MONTAGE-INSTRUCTIES

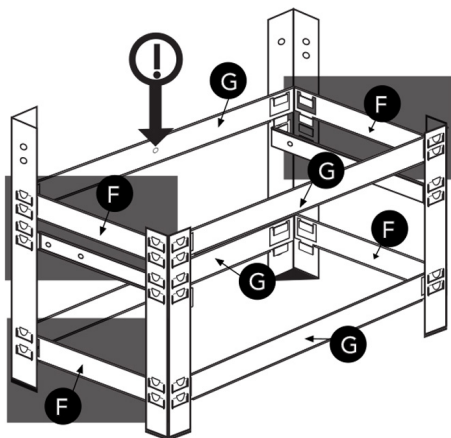

STAP 4:

Bevestig de 4 lange werkbladsteunen (G) aan de voor- en achterpoten (A, B, C) bij de 1e / 2e en 5e / 6e sleuf.

De lange werkbladsteun met het centrale gat moet tussen de 1e / 2e sleuf op de achterpoten (B, C) worden geplaatst.

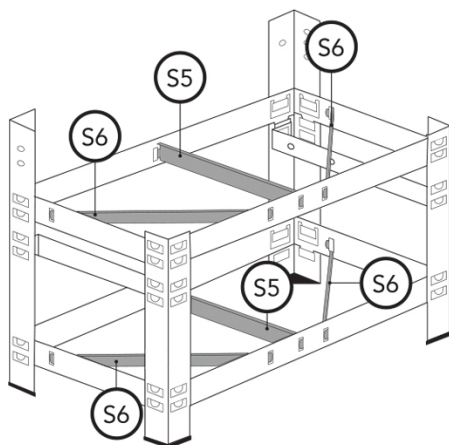

STAP 4.1:

Monteer de steunen (S5 & S6) op het frame.

STAP 5:

Buig de lipjes aan elk uiteinde van de steunbalken (S5) in een hoek van 90°. Zoek de sleuf aan de boven- en onderkant en schuif ze op hun plaats tussen de voorste en achterste zijbalken (G).

Buig de lipjes terug (zoals hieronder weergegeven) om te bevestigen.



Plaats de linker en rechter bovenste verticale steunen (H, I) in de zijkanalen van de achterpoten (B, C).

Zet vast met 4 korte schroeven (V).

Draai vast met een geschikte sleutel. Zet de Steunbalken (S5) vast met (W).

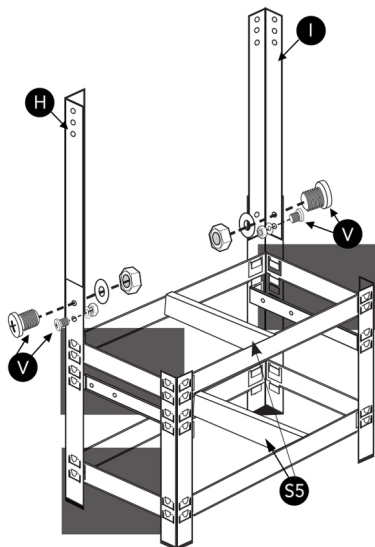

HANDLEIDING

MONTAGE-INSTRUCTIES

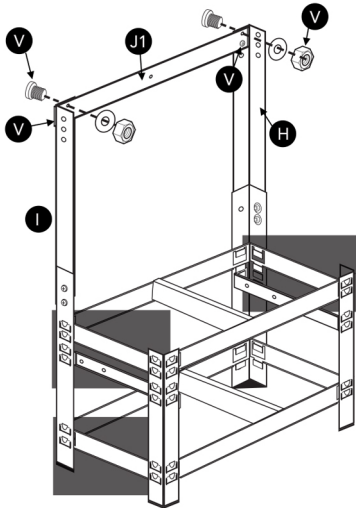

STAP 6:

Bevestig de rugsteun (J1) aan de bovenste 2 gaten van de verticale steunen (H, I). Zet vast met 4 korte schroeven (V). Draai vast.

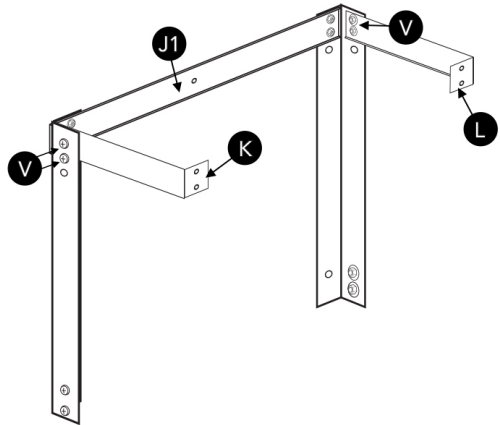

STAP 7:

Bevestig de langste rand van de korte bovenste plankdragers (K, L) aan de bovenste 2 gaten van de verticale steunen (H, I) met 4 korte schroeven (V) zoals afgebeeld. Draai vast.

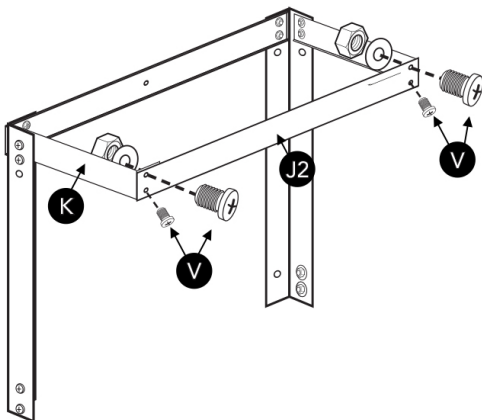

STAP 8:

Bevestig de voorste steun (J2) aan de voorkant van de korte bovenste plankdragers (K, L) met 4 korte schroeven (V) zoals afgebeeld. Draai vast.

HANDLEIDING

MONTAGE-INSTRUCTIES

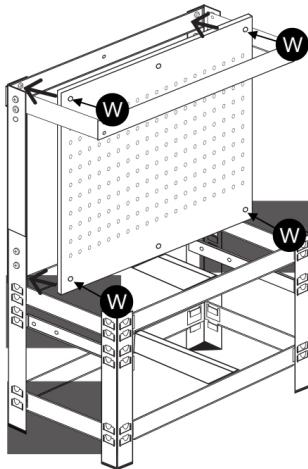

STAP 9:

Bevestig het ophangbord (Q) met 4 lange schroeven (W). Draai vast.

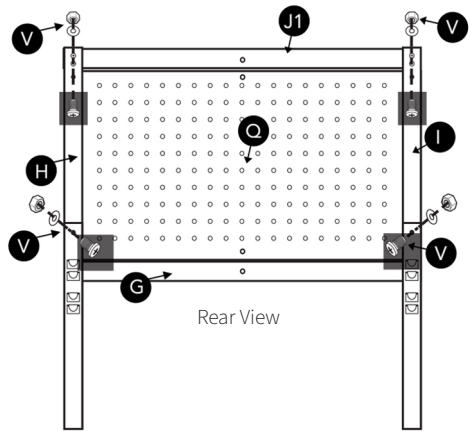

STAP 10:

Steek vanaf de achterkant 4 korte schroeven (V) in de lege gaten in de verticale steunen (H, I). Draai vast.

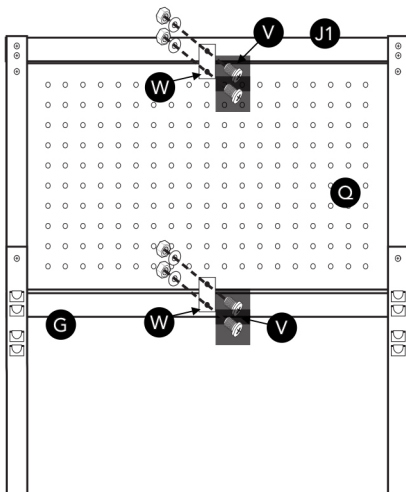

STAP 11:

Bevestig de Ophangbord-steunen (Y) met 2 korte schroeven (V) aan de achterkant van de constructie door de lege gaten op de lange steunen (G, J1).

Steek 2 Lange Schroeven (W) in de lege gaten op de Ophangbord-steunen (Y) en in het Ophangbord (Q). Draai alles stevig vast.

HANDLEIDING

MONTAGE-INSTRUCTIES

STAP 12:

Bevestig de 2 ladegreepjes (S1) aan het ladefront (M) door 8 kleine moeren / bouten (X) van buiten naar binnen in de richels te steken. Draai vast.

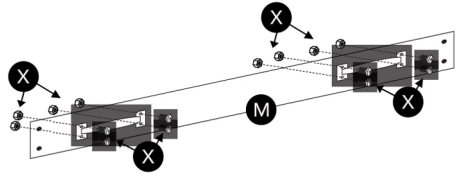

STAP 13:

Bevestig de Korte Ladezijden (O) aan het Ladefront (M) met 4 korte schroeven (V). Draai vast.

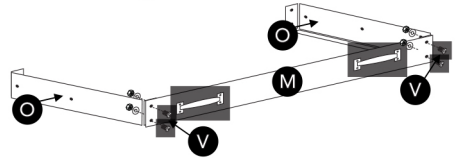

STAP 14:

Laat de Ladebodem (P) in de Ladeconstructie zakken om op de binnenste richels te rusten. Bevestig de Lade Achterkant (N) aan de montage met 4 korte schroeven (V).

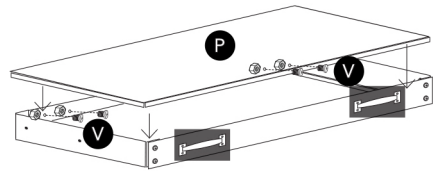

STAP 15:

Bevestig de 2 ladegeleiders (U) aan de korte ladekanten (O) met 4 kleine moeren / bouten (X) door de beschikbare gaten zoals afgebeeld. Draai vast.

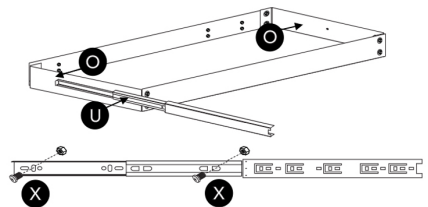

STAP 16:

Houd de lade voor werkbank, trek de ladegeleiders (U) uit en lijn ze uit met de bevestigingsgaten in de ladesteunen (D, E). Steek 4 kleine bouten (X) door de lopers en in de steunen. Draai vast.

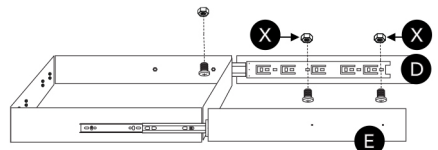

Plaats de ladesteun (S4) in het midden van de lade en zet hem vast met (W).

HANDLEIDING

MONTAGE-INSTRUCTIES

STAP 17:

Plaats het werkblad (S) en de onderste plank (R) door ze voorzichtig op de juiste niveaus op de werkbank te laten zakken, zoals afgebeeld.

EXTRA: Steek de pennen (S2) in het ophangbord (Q) om gereedschap handig op te hangen.

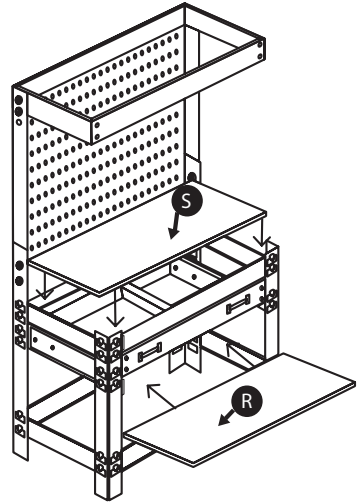

STAP 18:

Monteer de bovenste plank (T) door deze op het frame te plaatsen en op zijn plaats vast te zetten met 2 kleine moeren/bouten (X).

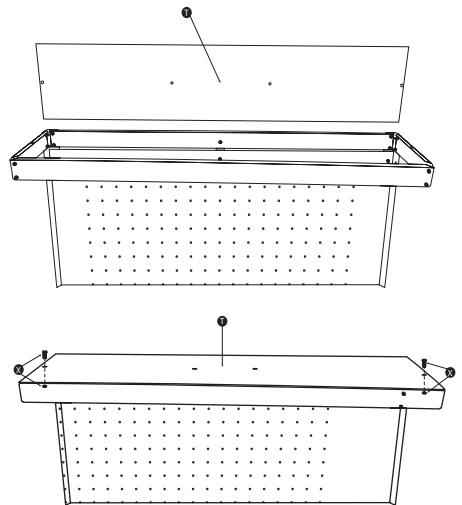
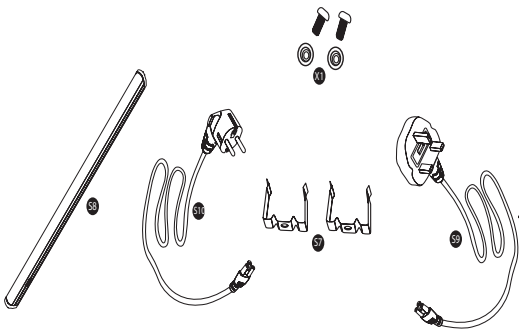

HANDLEIDING

MONTAGE-INSTRUCTIES

STAP 19:

Monteer vervolgens de LED-lichtbeugels (S7) aan de onderkant van de bovenste plank (T) met behulp van de 2 X-Small moeren/bouten (X1).

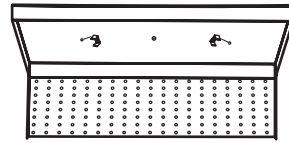
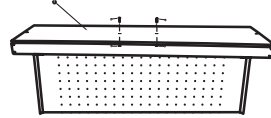

STAP 20:

Steek vervolgens ofwel het VK (S9) of de EU (S10) in de LED-lamp (S8).

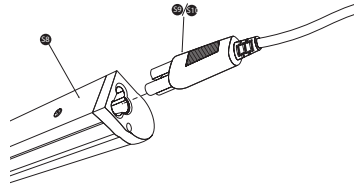

STAP 21:

Plaats de LED-lamp (S8) in de beugels (S7) die al onder de bovenste plank zijn gemonteerd totdat ze op hun plaats klikken.

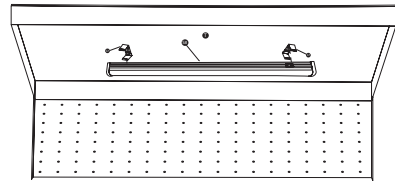

STAP 22:

Leid de overtollige kabel door het dichtstbijzijnde gat op het ophangbord, zodat het uit de buurt van je werkruimte is.

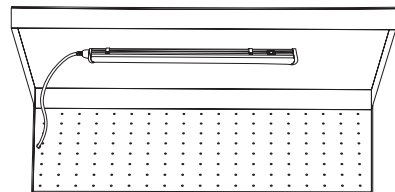

HANDLEIDING

ONDERHOUD

- Behandel de MDF-platen met vernis of schimmelwerende producten bij gebruik in een vochtige omgeving.
- Laat de LED-lamp 10 minuten afkoelen voordat u hem uit de beugels haalt of probeert schoon te maken. Reinig de LED-lamp alleen met een droge doek.

PROBLEMEN OPLOSSEN

RESOLUTIEGIDS

WAT MOET IK DOEN ALS ER ONDERDELEN ONTBREKEN UIT MIJN BESTELLING?

Als er een onderdeel ontbreekt in uw bestelling, neem dan binnen 7 dagen na ontvangst contact op met ons vriendelijke en behulpzame klantenserviceteam.

**VOOR ALLE ANDERE VRAGEN, NEEM CONTACT OP MET ONS
KLANTENSERVICETEAM.**

Monster Group (UK) is one of the UK's fastest growing online retailers. We supply a diverse range of products which offer exceptional value for money. We strive to provide the best possible customer experience with free UK delivery across all our products and a Monster Guarantee for 100% satisfaction.

For information regarding this device or other products from our Monster divisions please contact Sales.

SALES

TEL: 01347 878 888

EMAIL: hello@monstershop.co.uk

For queries about this device, warranty, returns or reporting faults please contact Support.

SUPPORT

TEL: 01347 878 887

EMAIL: help@monstershop.co.uk

Pour plus d'informations concernant cet appareil ou d'autres produits de nos divisions de Monster veuillez utiliser les détails suivants ci-dessous.

DÉPARTEMENT COMMERCIAL

TEL: 01347 878 888

EMAIL: bonjour@monstershop.eu

Pour les interrogations concernant cet appareil, la garantie, les retours ou les défauts de déclaration veuillez utiliser les détails suivants ci-dessous.

DÉPARTEMENT DE SOUTIEN

TEL: 01347 878 887

EMAIL: help@monstershop.co.uk

Para información sobre este dispositivo u otros productos de nuestras divisiones de Monster por favor use los siguientes detalles.

DEPARTAMENTO DE VENTAS

TEL: 01347 878 888

EMAIL: hola@monstershop.eu

Para consultas sobre este dispositivo, la garantía, devoluciones o denuncias de fallos por favor use los siguientes detalles.

DEPARTAMENTO DE SOPORTE

TEL: 01347 878 887

EMAIL: help@monstershop.co.uk

Für Informationen bezüglich dieses Geräts oder anderer produkte aus unserer Monster-Abteilung, benutzen sie die folgenden unten aufgeführten angaben.

VERKAUFABTEILUNG

TEL: 01347 878 888

EMAIL: hallo@monstershop.eu

Für fragen über dieses gerät, die garantie, rückgaben oder bei störungen, benutzen sie die folgenden unten aufgeführten angaben.

SUPPORT-ABTEILUNG

TEL: 01347 878 887

EMAIL: help@monstershop.co.uk

Per informazioni riguardanti questo dispositivo o altri prodotti dalle categorie Monster utilizzare i dettagli sotto riportati.

DIPARTIMENTO VENDITE

TEL: 01347 878 888

EMAIL: ciao@monstershop.eu

Per domande riguardo dispositivo, garanzia, reso o per riferire di guasti, utilizzare i dettagli sotto riportati.

DIPARTIMENTO SUPPORTO

TEL: 01347 878 887

EMAIL: help@monstershop.co.uk

Monster House, Alan Farnaby Way,
Sheriff Hutton Industrial Estate,
Sheriff Hutton, York, YO60 6PG
www.monstershop.co.uk



 Try **Monster**. Buy **Monster**. Be **Monster**. 